

CS - Cylinder Configuration Sampling Systems for Liquefied Gases

CSF1 - System Purge Type with Expansion Chamber

Features

- ⦿ Sampling from devices or process lines
- ⦿ System purge
- ⦿ Predefined sampling volume controlled by an expansion chamber to ensure safe sampling
- ⦿ Easy operation with a single handle by linkage valve

Basic Configuration

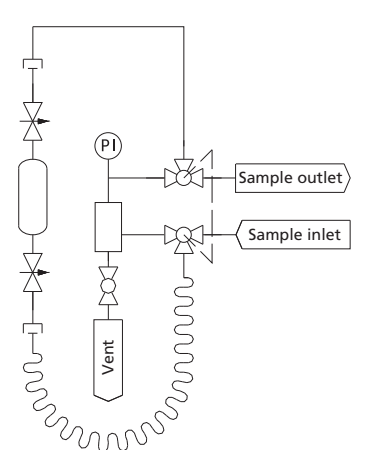
Wetted Material	316 SS	
Cylinder Assembly	500 ml cylinder	
	ND Series needle valves QC4 Series quick-connects	
Sampling Valve	BF Series ball valves (gearbox linkage): PTFE seat and FKM O-ring Max. working pressure: 1500 psig @ 70°F (103 bar @ 20°C) Temperature range: 0°F to 450°F (-18°C to 232°C)	
Expansion Chamber	100ml, to control the predefined sampling volume to 80% of the cylinder volume	
Other Accessories	PS Series metal hoses Pressure gauge	
Connections	NPS 1/2 flange	

Note: Products of other specifications are available upon request.

Typical Installation Mode

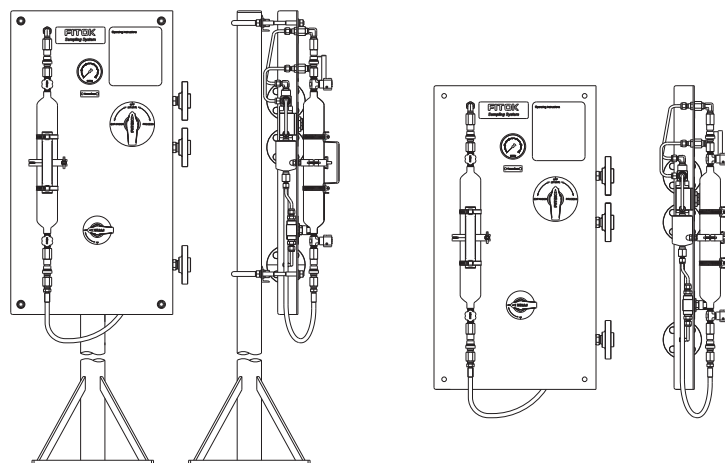

Operation

1 - Preparation

Install the sample cylinder and connect the hose to the bottom side of the cylinder. Open the needle valves at both ends of the cylinder.

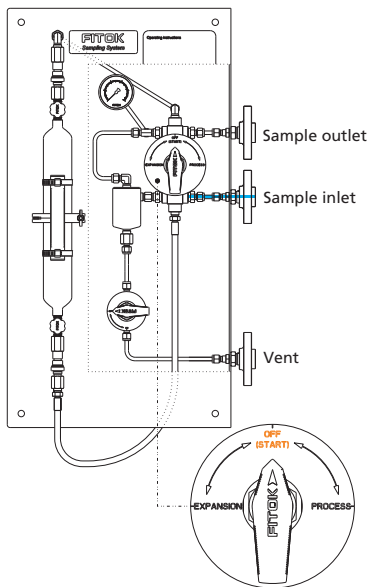

2 - Sampling

Turn the handle to the "PROCESS" position, allowing the sample to flow continuously into and fill the cylinder. Hold for a period of time to ensure representative sampling.

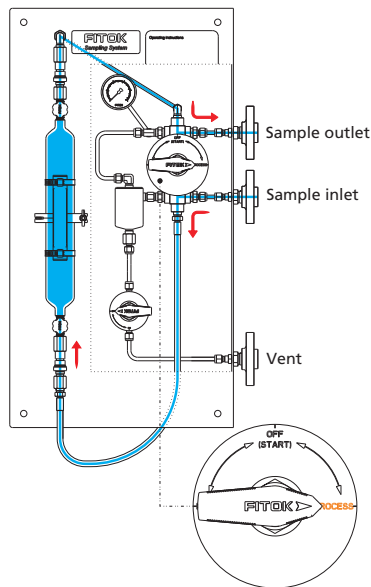

3 - Expansion

Turn the handle to the "EXPANSION" position, connecting the cylinder with the expansion chamber. Hold for a period of time to transfer a portion of sample to the expansion chamber. Close the needle valves at both ends of the cylinder.

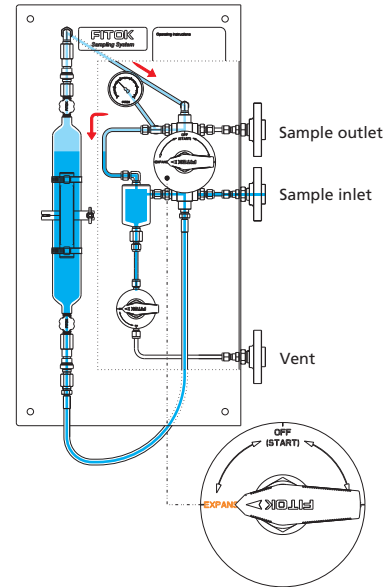

4 - Depressurization/vent

Open the ball valve on the expansion chamber to depressurize and discharge the residual sample out of the sampling line and the expansion chamber. Subsequently, close the ball valve.

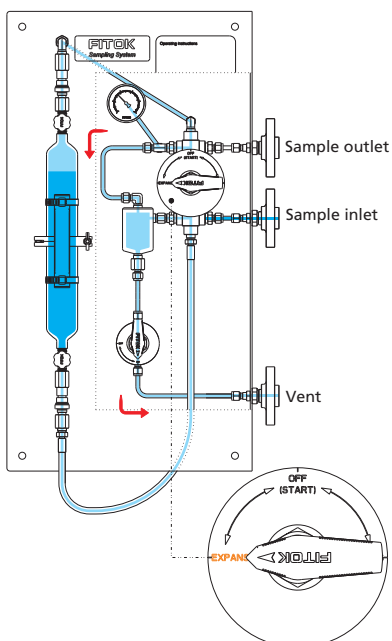

5 - Off

Turn the handle to the "OFF" position and disconnect the hose. Remove the cylinder and connect the hose to the top quick-connect to complete the sampling process.

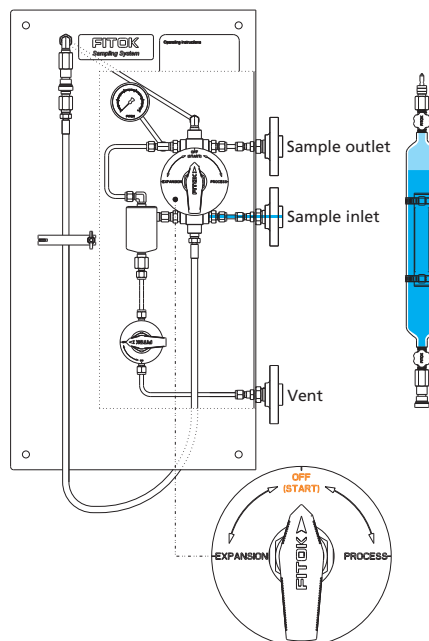

CSF2 - Expansion Chamber Purge Type

Features

- Sampling from devices or process lines
- System purge and expansion chamber purge
- Predefined sampling volume controlled by an expansion chamber to ensure safe sampling
- Easy operation with a single handle

Basic Configuration

Wetted Material	316 SS	
Cylinder Assembly	500 ml cylinder ND Series needle valves QC4 Series quick-connects	
Sampling Valve	BF Series ball valves (gearbox linkage): PTFE seat and FKM O-ring Max. working pressure: 1500 psig @ 70°F (103 bar @ 20°C) Temperature range: 0°F to 450°F (-18°C to 232°C)	
Nitrogen Branch	Nitrogen regulator CV Series check valves Pressure gauge	
Expansion Chamber	100ml, to control the predefined sampling volume to 80% of the cylinder volume	
Other Accessories	PS Series metal hoses Pressure gauge	
Connections	NPS 1/2 flange	

Note: Products of other specifications are available upon request.

Typical Installation Mode

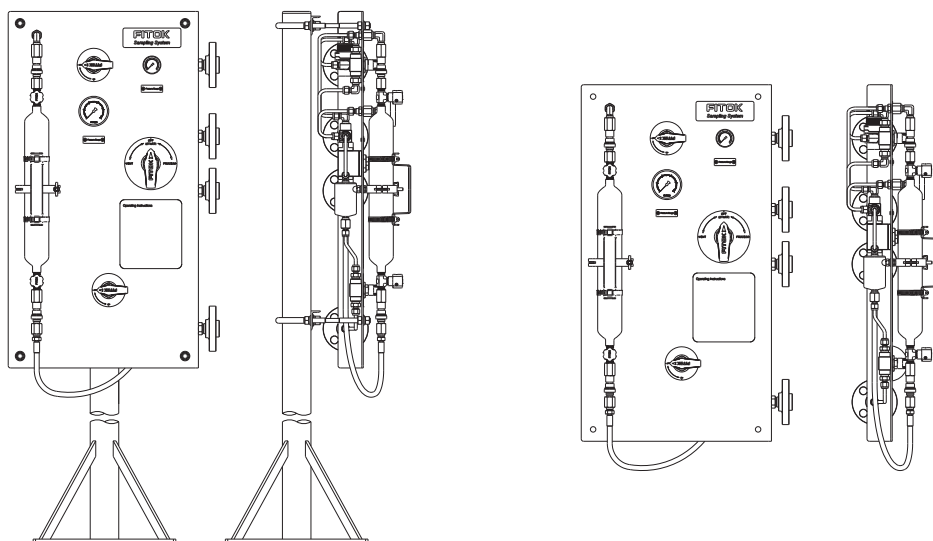

Operation

1 - Preparation

Install the sample cylinder and connect the hose to the bottom side of the cylinder. Open the needle valves at both ends of the cylinder.

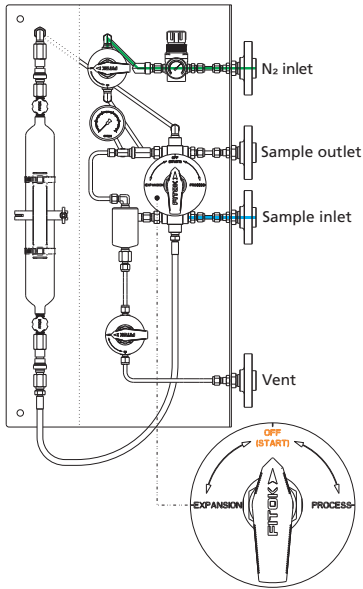

2 - Sampling

Turn the handle to the "PROCESS" position, allowing the sample to flow continuously into and fill the cylinder. Hold for a period of time to ensure representative sampling.

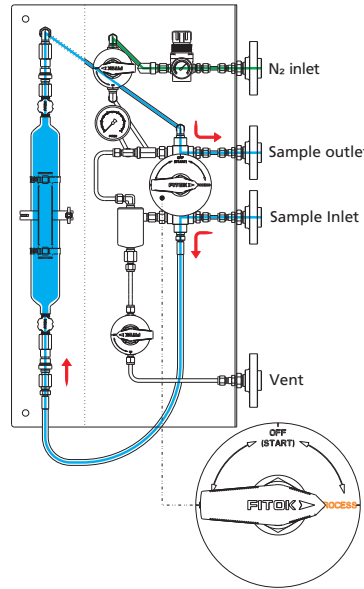

3 - Expansion

Turn the handle to the "EXPANSION" position, connecting the cylinder with the expansion chamber. Hold for a period of time to transfer a portion of sample to the expansion chamber. Close the needle valves at both ends of the cylinder.

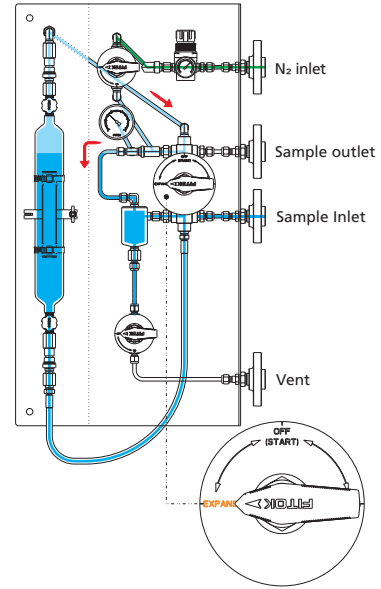

4 - Purge

Open the ball valve on the expansion chamber and the ball valve on the vent branch, allowing Nitrogen to purge the expansion chamber. Subsequently, close all the ball valves.

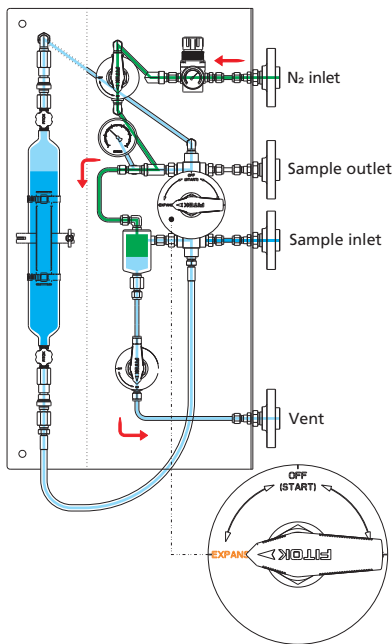

5 - Off

Turn the handle to the "OFF" position and disconnect the hose. Remove the cylinder and connect the hose to the top quick-connect to complete the sampling process.

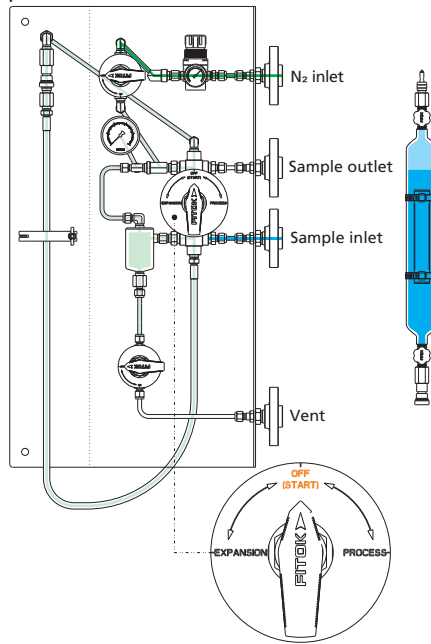

CSF3 - Bypass Purge Type with Expansion Chamber

Features

- Sampling from devices or process lines
- System purge and bypass purge
- Predefined sampling volume controlled by an expansion chamber to ensure safe sampling
- Easy operation with a single handle by linkage valve

Basic Configuration

Wetted Material	316 SS	
Cylinder Assembly	500 ml cylinder	
	ND Series needle valves	
	QC4 Series quick-connects	
	CV Series check valves	
Sampling Valve	BF Series ball valves (gearbox linkage): PTFE seat and FKM O-ring Max. working pressure: 1500 psig @ 70°F (103 bar @ 20°C) Temperature range: 0°F to 450°F (-18°C to 232°C)	
Nitrogen Branch	Nitrogen regulator	
	CV Series check valves	
	Pressure gauge	
Expansion Chamber	100ml, to control the predefined sampling volume to 80% of the cylinder volume	
Other Accessories	PS Series metal hoses	
	Pressure gauge	
Connections	NPS 1/2 flange	

Note: Products of other specifications are available upon request.

Typical Installation Mode

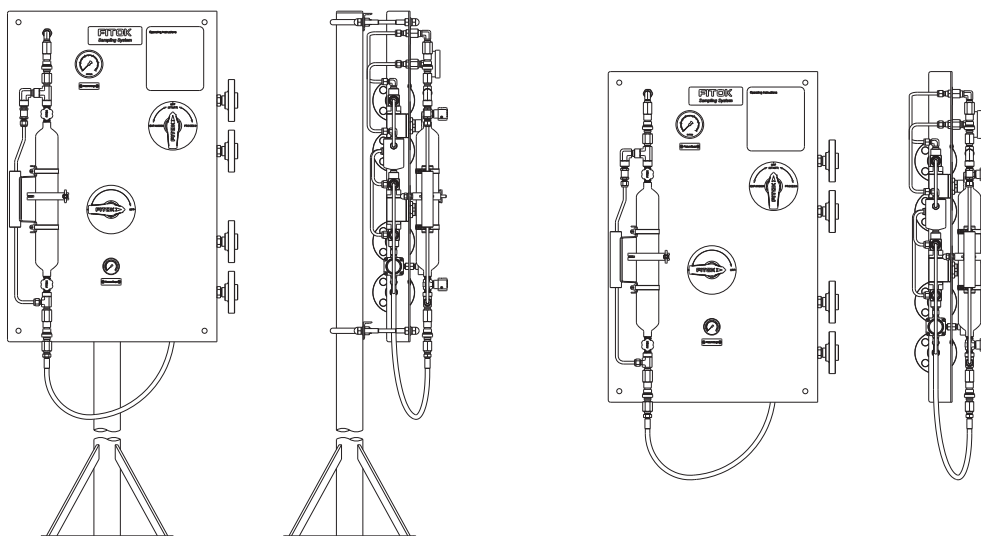

Operation

1 - Preparation

Install the sample cylinder and connect the hose to the bottom side of the cylinder. Open the needle valves at both ends of the cylinder.

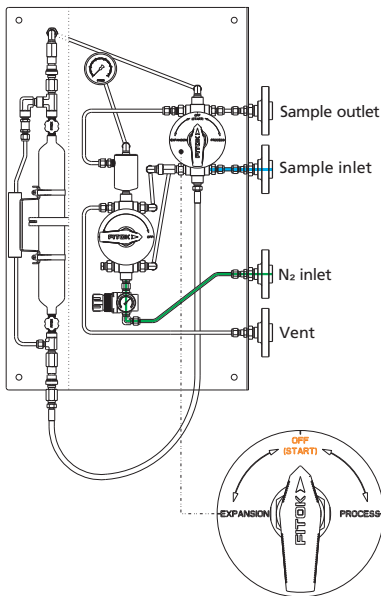

2 - Pre-sampling

Turn the handle to the "PROCESS" position, allowing the sample to flow continuously into and fill the cylinder. Hold for a period of time to ensure representative sampling.

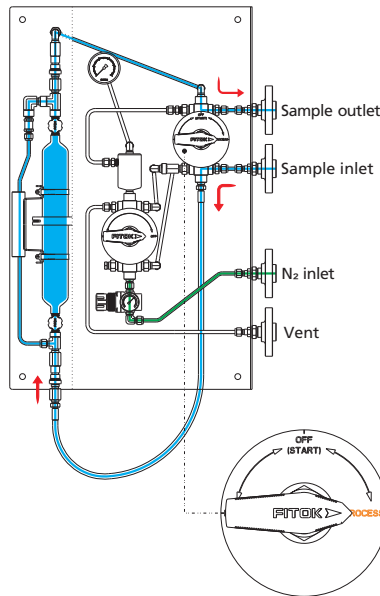

3 - Expansion

Turn the handle to the "EXPANSION" position, connecting the cylinder with the expansion chamber. Hold for a period of time to transfer a portion of sample to the expansion chamber. Close the needle valves at both ends of the cylinder.

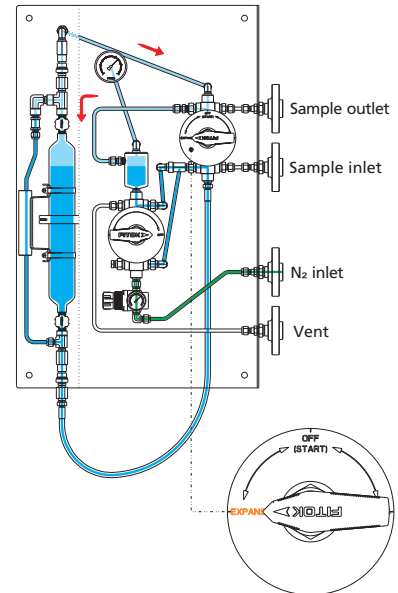

4 - Purge

Turn the handle of the valve on the purge line to the "PURGE" position, allowing Nitrogen to flow through the quick-connects and bypass to force the residual sample out of the system.

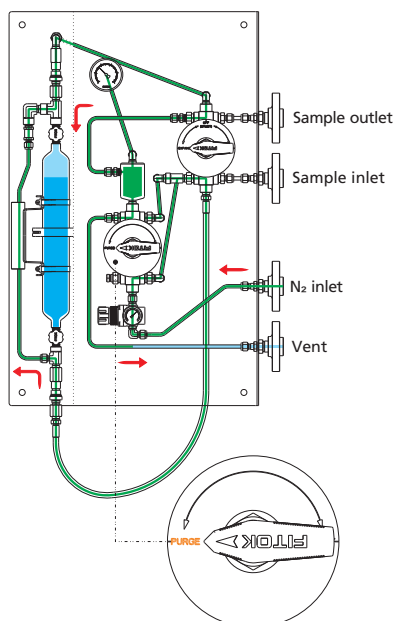

5 - Off

Turn the two handles to the "OFF" position and disconnect the hose. Remove the cylinder and connect the hose to the top quick-connect to complete the sampling process.

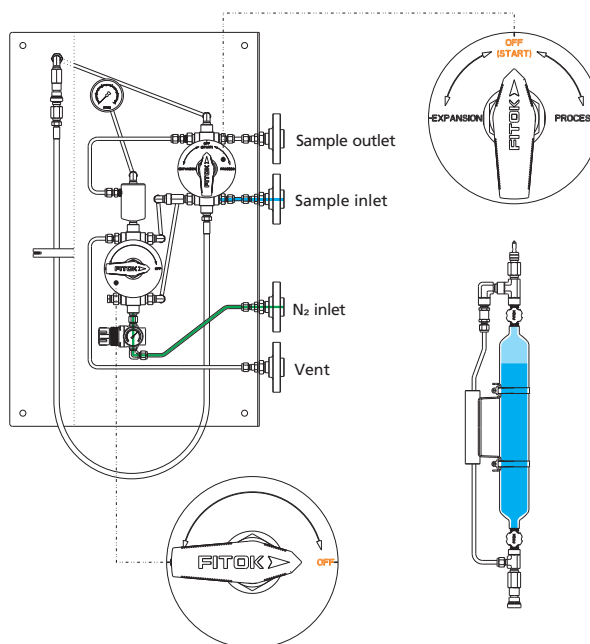

CSF4 - Vent to Flare Type with Expansion Chamber

Features

- Sampling from devices or process lines
- System purge to flare (no circulation loop)
- Predefined sampling volume controlled by an expansion chamber to ensure safe sampling
- Easy operation with a single handle by linkage valve

Basic Configuration

Wetted Material	316 SS	
Cylinder Assembly	500 ml cylinder	
	ND Series needle valves	
	QC4 Series quick-connects	
Sampling Valve	BF Series ball valves (gearbox linkage): PTFE seat and FKM O-ring Max. working pressure: 1500 psig @ 70°F (103 bar @ 20°C) Temperature range: 0°F to 450°F (-18°C to 232°C)	
Expansion Chamber	100 ml, to control the predefined sampling volume to 80% of the cylinder volume	
Other Accessories	PS Series metal hoses	
	Pressure gauge	
Connections	NPS 1/2 flange	

Note: Products of other specifications are available upon request.

Typical Installation Mode

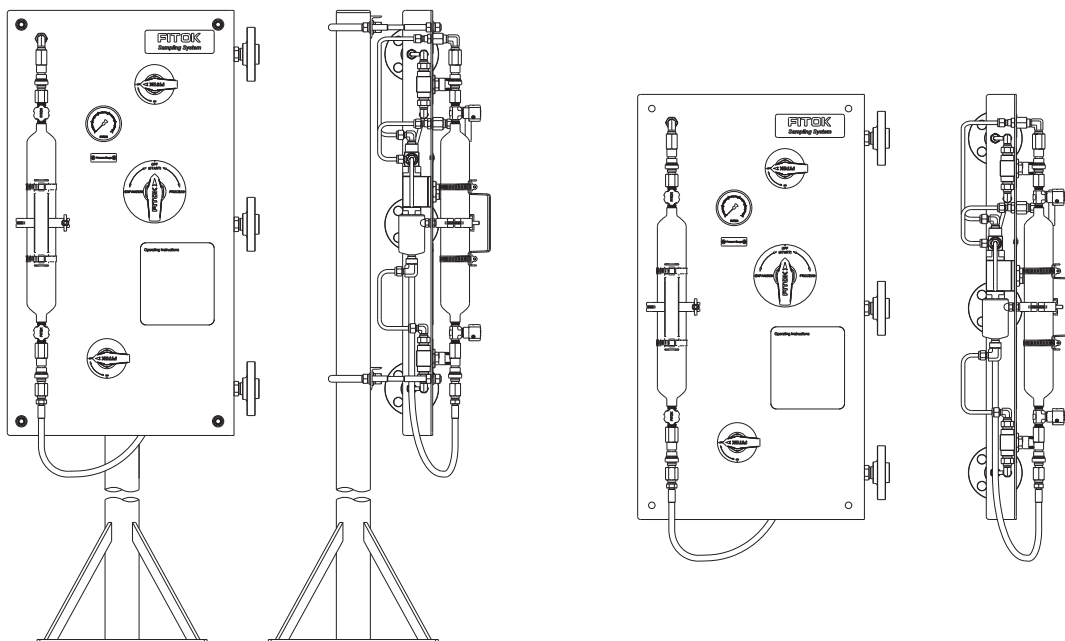

Operation

1 - Preparation

Install the sample cylinder and connect the hose to the bottom side of the cylinder. Open the needle valves at both ends of the cylinder.

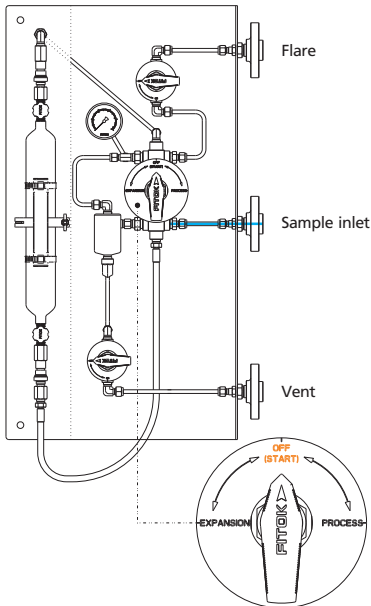

2 - Pre-sampling

Turn the handle to the "PROCESS" position, allowing the sample to flow into and fill the cylinder.

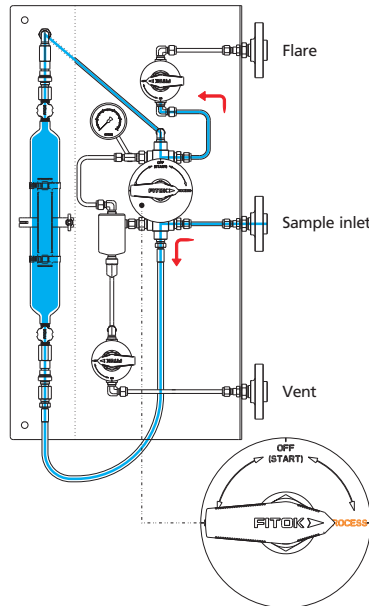

3 - Sampling

Open the ball valve on the flare line, connecting the sampling line to the flare to allow the sample to flow continuously into the cylinder. Hold for a period of time to ensure representative sampling. Subsequently, close the ball valve.

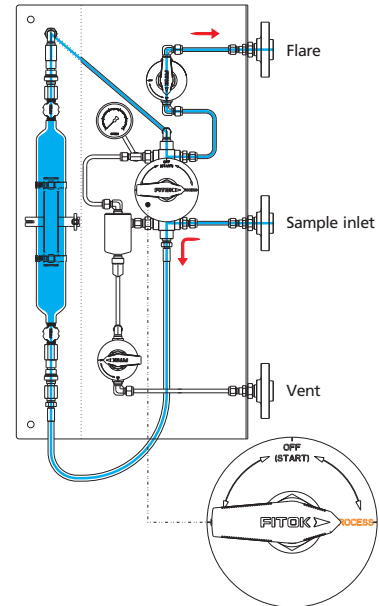

4 - Expansion

Turn the handle to the "EXPANSION" position, connecting the cylinder with the expansion chamber. Hold for a period of time to transfer a portion of sample to the expansion chamber. Close the needle valves at both ends of the cylinder.

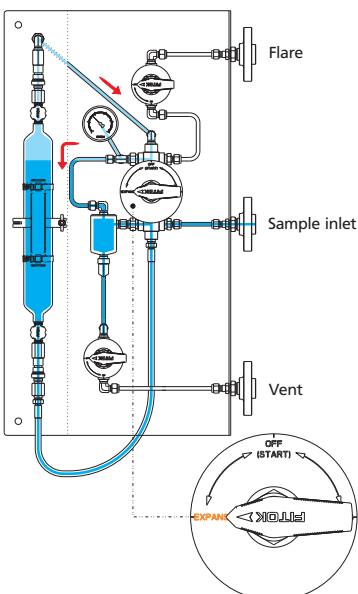

5 - Depressurization/vent

Open the ball valve on the expansion chamber, connecting with the vent line to depressurize and discharge the residual sample out of the system. Subsequently, close the ball valve.

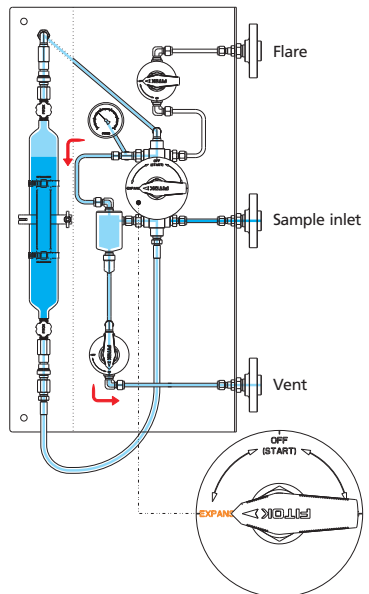

6 - Off

Turn the handle to the "OFF" position and disconnect the hose. Remove the cylinder and connect the hose to the top quick-connect to complete the sampling process.

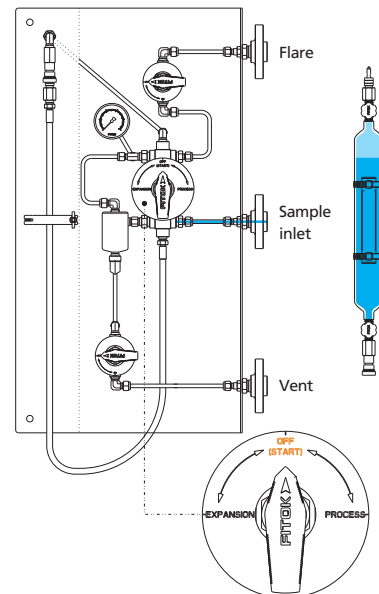

CSF5 - Outage Tube Type

Features

- Sampling from devices or process lines
- System purge
- Predefined sampling volume controlled by an outage tube to ensure safe sampling
- Easy operation with a single handle by linkage valve

Basic Configuration

Wetted Material	316 SS
Cylinder Assembly	500 ml cylinder
	ND Series needle valves
	QC4 Series quick-connects
Sampling Valve	BF Series ball valves (gearbox linkage): PTFE seat and FKM O-ring Max. working pressure: 1500 psig @ 70°F (103 bar @ 20°C) Temperature range: 0°F to 450°F (-18°C to 232°C)
Outage Tube	To control the predefined sampling volume to 80% of the cylinder volume
Other Accessories	PS Series metal hoses
	Pressure gauge
Connections	NPS 1/2 flange

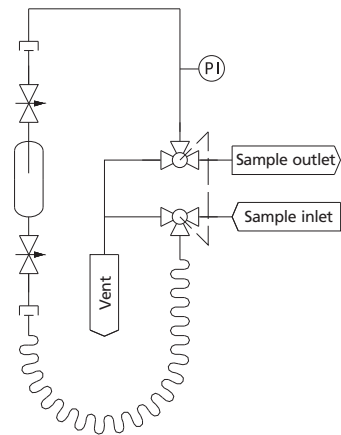

Note: Products of other specifications are available upon request.

Typical Installation Mode

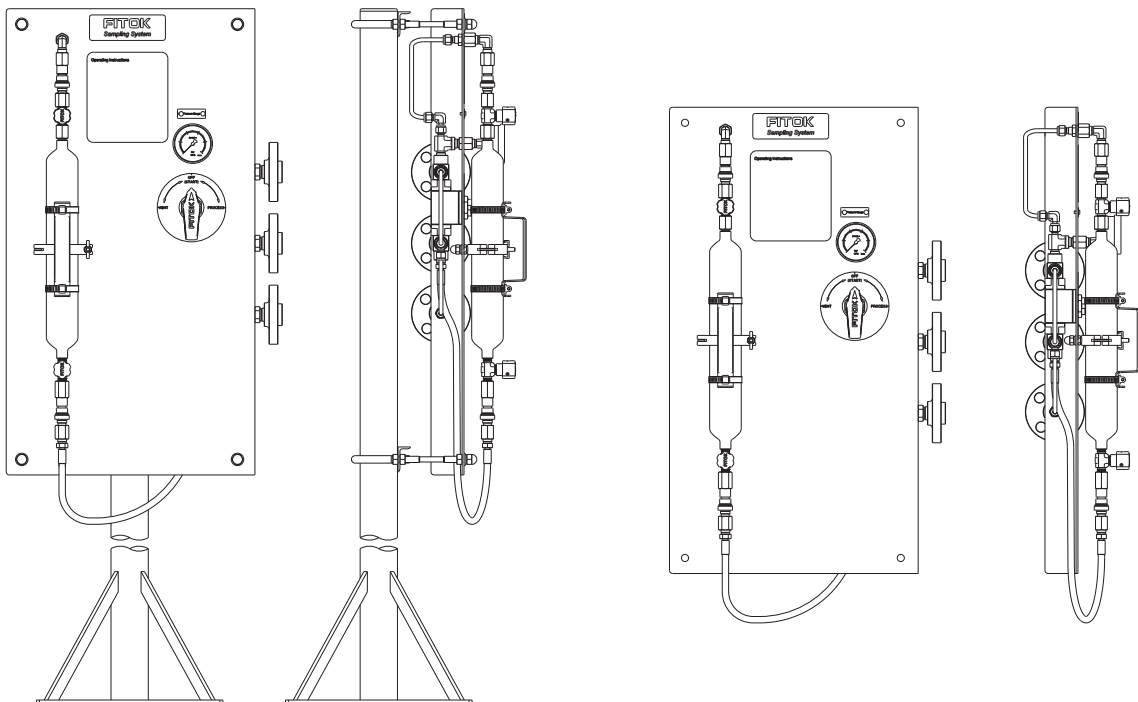

Operation

1 - Preparation

Install the sample cylinder and connect the hose to the bottom side of the cylinder. Open the needle valves at both ends of the cylinder.

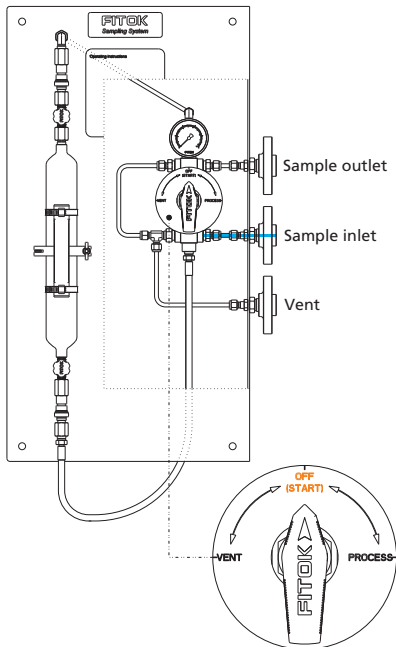

2 - Sampling

Turn the handle to the "PROCESS" position, allowing the sample to flow continuously into and fill the sample cylinder. Hold for a period of time to ensure representative sampling.

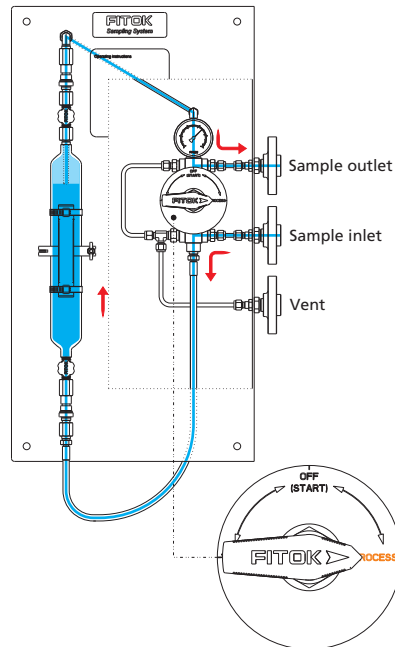

3 - Off

Turn the handle to the "OFF" position. Close the needle valves at both sides of the cylinder.

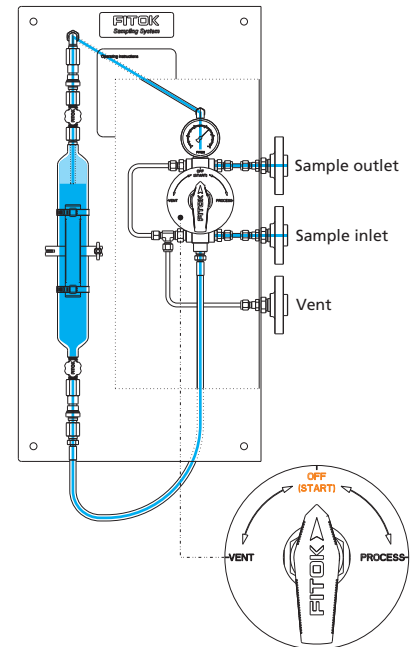

4 - Depressurization/vent

Turn the handle to the "VENT" position, connecting the sampling line with the vent line to depressurize and discharge the residual sample out of the system.

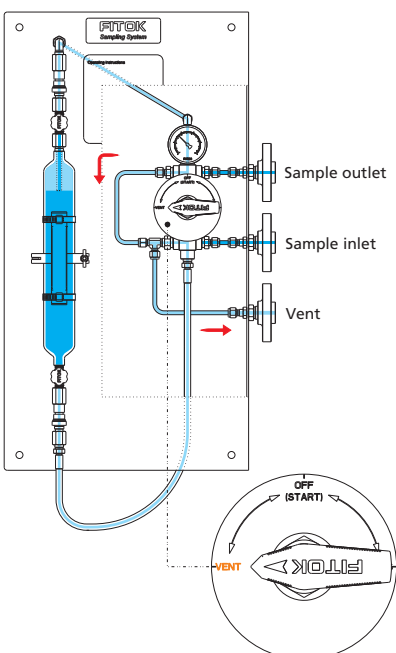

5 - Off

Turn the handle to the "OFF" position and disconnect the hose. Remove the cylinder and connect the hose to the top quick-connect to complete the sampling process.

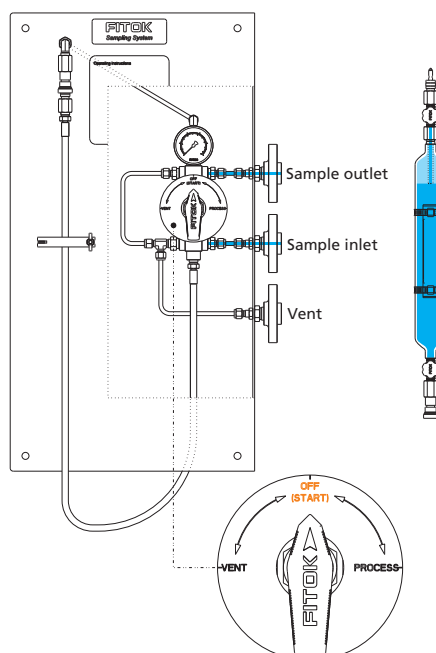

CSF6 - Bypass Purge Type with Outage Tube

Features

- Sampling from devices or process lines
- System purge and bypass purge
- Predefined sampling volume controlled by an outage tube to ensure safe sampling
- Easy operation with a single handle by linkage valve

Basic Configuration

Wetted Material	316 SS	
	500 ml cylinder	
Cylinder Assembly	ND Series needle valves	
	QC4 Series quick-connects	
	CV Series check valves	
Sampling Valve	BF Series ball valves (gearbox linkage): PTFE seat and FKM O-ring Max. working pressure: 1500 psig @ 70°F (103 bar @ 20°C) Temperature range: 0°F to 450°F (-18°C to 232°C)	
Nitrogen Branch	Nitrogen regulator	
	CV Series check valves	
	Pressure gauge	
Outage Tube	To control the predefined sampling volume to 80% of the cylinder volume	
Other Accessories	PS Series metal hoses	
	Pressure gauge	
Connections	NPS 1/2 flange	

Note: Products of other specifications are available upon request.

Typical Installation Mode

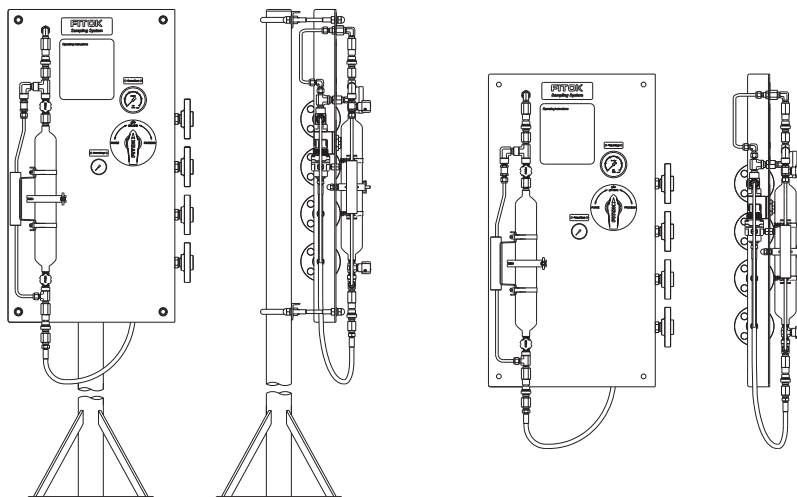

Operation

1 - Preparation

Install the sample cylinder and connect the hose to the bottom side of the cylinder. Open the needle valves at both ends of the cylinder.

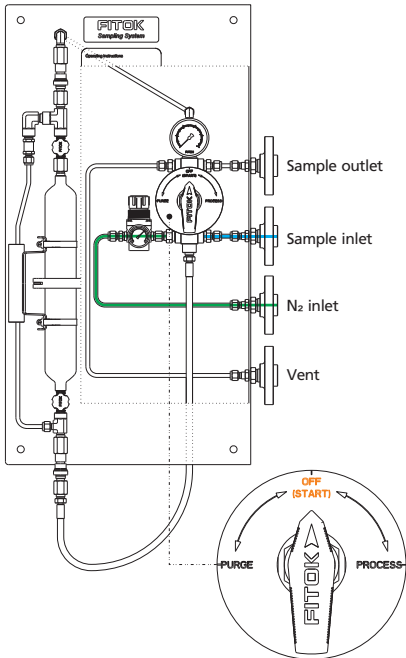

2 - Sampling

Turn the handle to the "PROCESS" position, allowing the sample to flow continuously into and fill the cylinder. Hold for a period of time to ensure representative sampling.

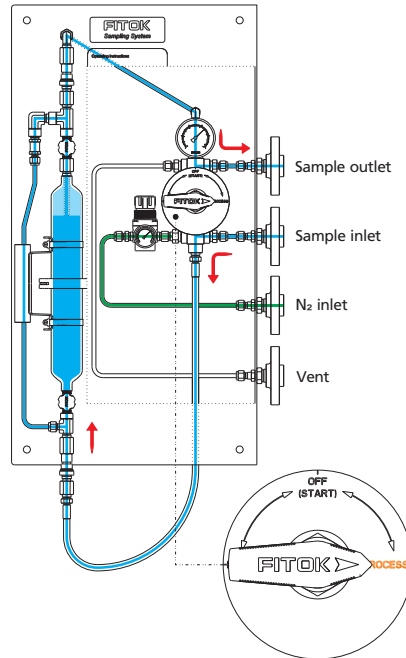

3 - Off

Turn the handle to the "OFF" position. Close the needle valves at both ends of the cylinder.

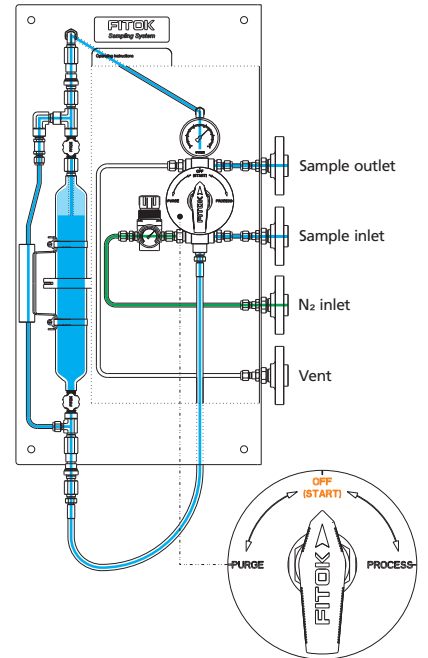

4 - Purge

Turn the handle to the "PURGE" position, allowing Nitrogen to force the residual sample out of the system.

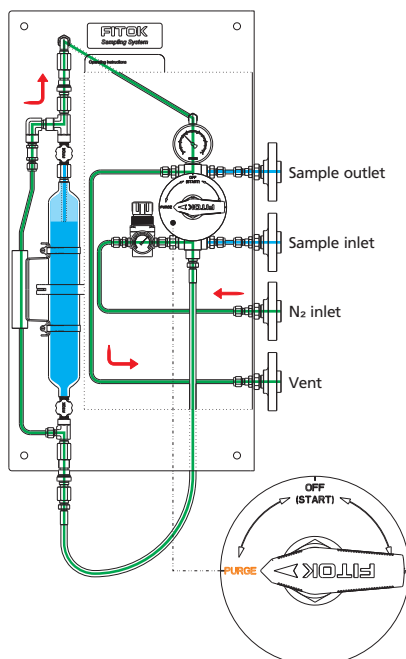

5 - Off

Turn the handle to the "OFF" position and disconnect the hose. Remove the cylinder and connect the hose to the top quick-connect to complete the sampling process.

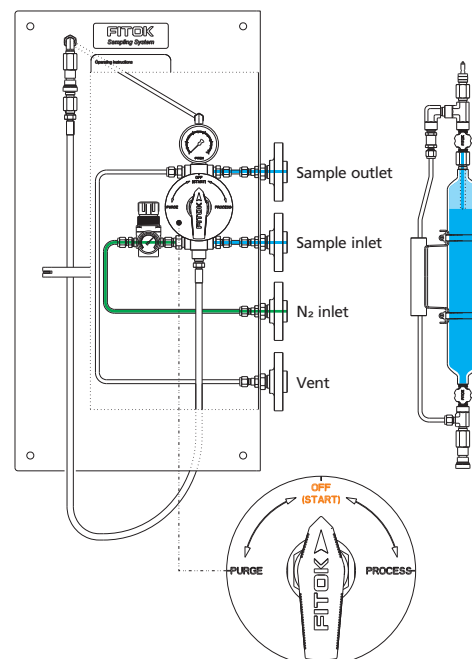

CSF7 - Vent to Flare Type with Outage Tube

Features

- Sampling from devices or process lines
- System purge to flare (no circulation loop)
- Predefined sampling volume controlled by an outage tube to ensure safe sampling
- Easy operation with a single handle by linkage valve

Basic Configuration

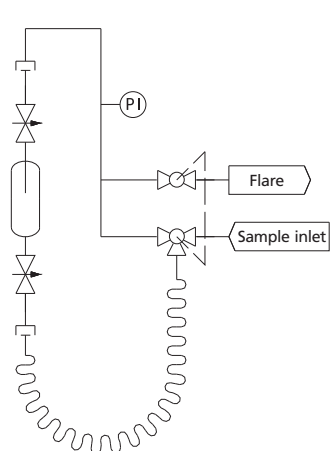
Wetted Material	316 SS	
Cylinder Assembly	500 ml cylinder	
	ND Series needle valves	
	QC4 Series quick-connects	
Sampling Valve	BF Series ball valves (gearbox linkage): PTFE seat and FKM O-ring Max. working pressure: 1500 psig @ 70°F (103 bar @ 20°C) Temperature range: 0°F to 450°F (-18°C to 232°C)	
Expansion Chamber	To control the predefined sampling volume to 80% of the cylinder volume	
Other Accessories	PS Series metal hoses	
	Pressure gauge	
Connections	NPS 1/2 flange	

Note: Products of other specifications are available upon request.

Typical Installation Mode

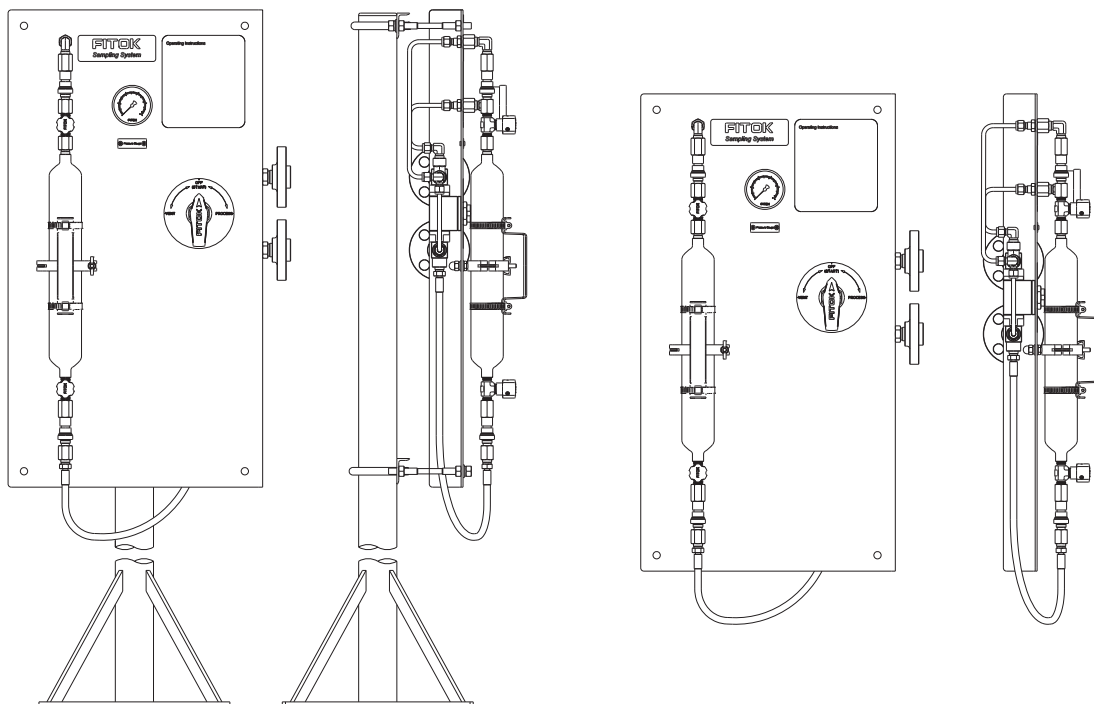

Operation

1 - Preparation

Install the sample cylinder and connect the hose to the bottom side of the cylinder. Open the needle valves at both ends of the cylinder.

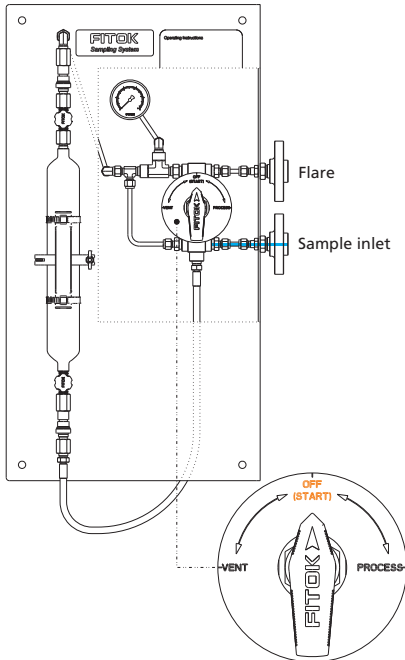

2 - Sampling

Turn the handle to the "PROCESS" position, allowing the sample to flow continuously into and fill the sample cylinder. Hold for a period of time to ensure representative sampling.

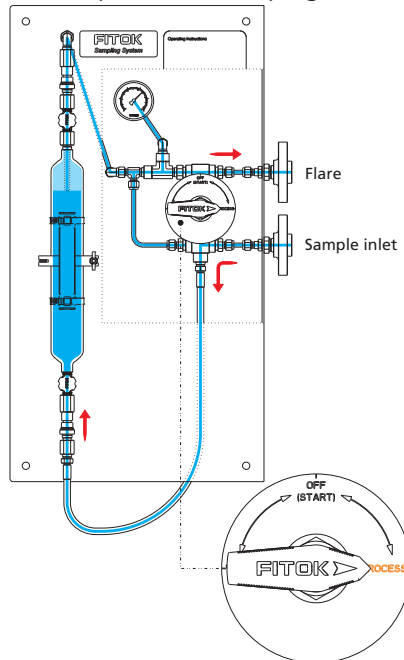

3 - Off

Turn the handle to the "OFF" position. Close the needle valves at both sides of the cylinder.

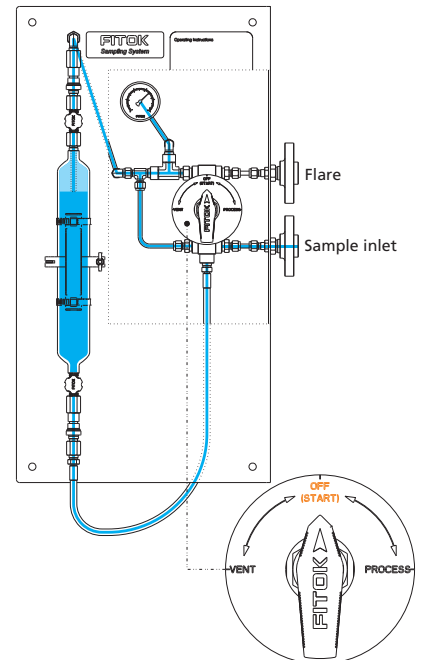

4 - Depressurization/vent

Turn the handle to the "VENT" position, connecting the sampling line to the flare to depressurize and discharge the residual sample out of the system.

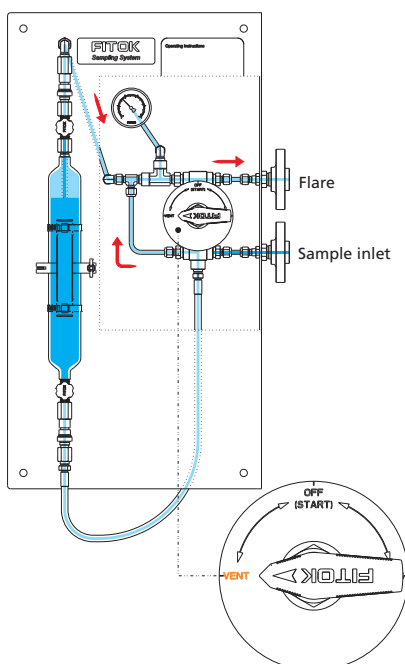

5 - Off

Turn the handle to the "OFF" position and disconnect the hose. Remove the cylinder and connect the hose to the top quick-connect to complete the sampling process.

