

Needle Valves and Pneumatic Needle Valves

10N Series: 10,000 psig (690 bar)

15N Series: 15,000 psig (1034 bar)

20N Series: 20,000 psig (1379 bar)

30N Series: 30,000 psig (2068 bar)

60N Series: 60,000 psig (4137 bar)



Fittings
Tubing
Quick Couplings
Line Filters
Valves
Sour Service Products
Subsea Valves
Tools and Installation Instructions
Technical Information
Part Number Crossover Charts

Contents

Needle Valves

Fittings	10N Series: 10,000 psig (690 bar)	E-13
Tubing	15N Series: 15,000 psig (1034 bar)	E-19
Quick Couplings	20N Series: 20,000 psig (1379 bar)	E-26
Line Filters	30N Series: 30,000 psig (2068 bar)	E-31
	60N Series: 60,000 psig (4137 bar)	E-35

Pneumatic Needle Valves

Valves	Piston Style Air to Open (Normally Closed)	E-39
Sour Service Products	Piston Style Air to Close (Normally Open)	E-45

Ordering Number Description

Subsea Valves		E-49
---------------	--	------

Fittings
Tubing
Quick Couplings
Line Filters
Valves
Sour Service Products
Subsea Valves
Tools and Installation Instructions
Technical Information
Part Number Crossover Charts

Needle Valves

10N Series: 10,000 psig (690 bar)

Features

- ⦿ High tensile 316 Stainless Steel for the valve body and S17400 Stainless Steel for lower stem
- ⦿ Metal-to-metal seating to achieve ideal shutoff, longer stem/seat service lifetime for abrasive flow, excellent corrosion resistance and greater durability for repeated on/off cycles
- ⦿ Non-rotating stem and bar stock body design
- ⦿ Easy to assemble and replace packing
- ⦿ Reliable packing gland locking device
- ⦿ Options for Vee or Regulating stem tips
- ⦿ Five flow patterns available

Technical Data

Connection Size	Connection	Orifice in. (mm)	Cv	Working Pressure psig (bar)	Working Temperature Range
9/16" Female Medium Pressure	MF9	0.359 (9.12)	1.75	10,000 (690)	-100°F~1200°F (-73°C~649°C)
3/4" Female Medium Pressure	MF12	0.516 (13.10)	2.80	10,000 (690)	
1" Female Medium Pressure	MF16	0.688 (17.48)	5.20	10,000 (690)	
3/4" Female NPT	FNS12	0.437 (11.10)	2.50	10,000 (690)	-100°F~400°F (-73°C~204°C)
3/4" Female ISO Tapered Thread	FRT12				
1" Female NPT	FNS16	0.562 (14.27)	4.40	10,000 (690)	
1" Female ISO Tapered Thread	FRT16				

NOTES: 1. Cv values shown are for 2-way straight valve pattern. For 2-way angle pattern, increase Cv value by about 50% (Based on water).

2. Packing Options

PTFE is the standard packing material, RPTFE glass, Graphite and extended stuffing box with Graphite also available. Graphite packing not recommended for Hydrogen or Helium service.

PTFE: -100°F~450°F (-73°C~232°C)

RPTFE glass: -100°F~600°F (-73°C~316°C)

Graphite: 0°F~800°F (-17.8°C~427°C)

Extended stuffing box with Graphite: 0°F~1200°F (-17.8°C~649°C)

Fittings

Tubing

Quick Couplings

Line Filters

Valves

Sour Service Products

Subsea Valves

Tools and Installation Instructions

Technical Information

Part Number Crossover Charts

Flow Data at 100°F (38°C)

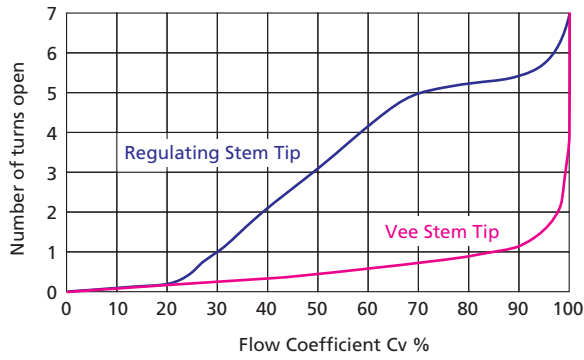

Pressure vs. Temperature Curve

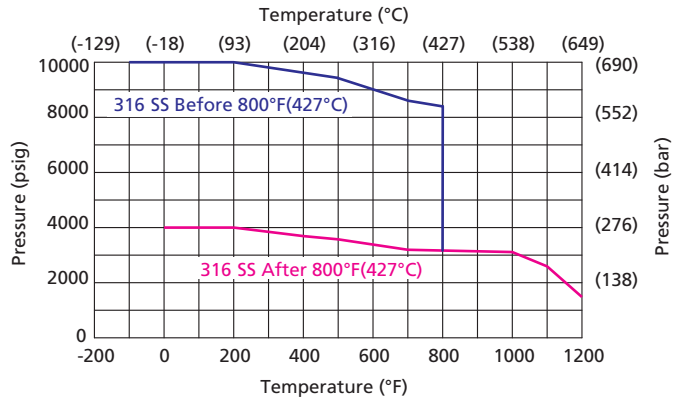

NOTE: When temperature exceeds 800°F (427°C), use the pink curve as its cold-worked rating for future operating of the components.

Standard Materials of Construction

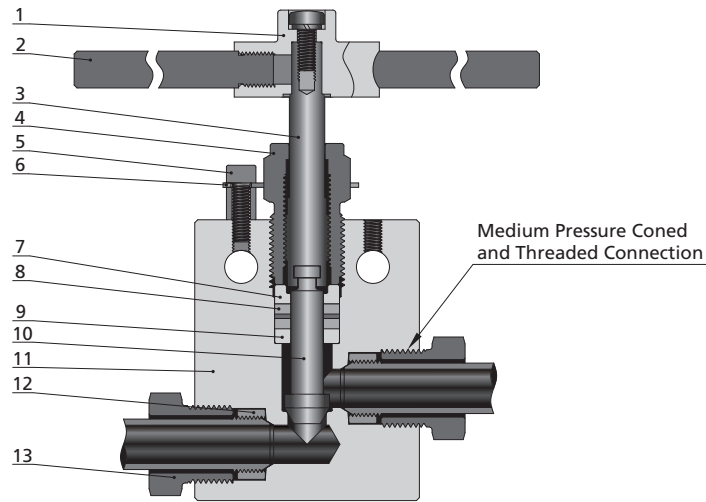

Item	Component	Material Grade
1	Handle Head	Stainless steel
2	Handle	Stainless steel
3	Upper Stem	316 SS
4	Packing Gland	C63000
5	Locking Screw	Stainless steel
6	Locking Plate	304 SS
7	Packing Ring	C63000
8	<i>Packing</i>	<i>PTFE/RPTFE glass/Graphite/Extended stuffing box with Graphite</i>
9	<i>Packing Washer</i>	<i>S17400</i>
10	<i>Lower Stem</i>	<i>S17400</i>
11	<i>Body</i>	<i>316 SS</i>
12	Collar	316 SS (For tubing connections)
13	Gland	316 SS (For tubing connections)
	Lubricant	Molybdenum disulfide

Wetted component listed in italics.

- fittings
- tubing
- quick couplings
- line filters
- valves
- sour service products
- subsea valves
- tools and installation instructions
- technical information
- part number crossover charts

Ordering Information and Dimensions (Tubing Connection, 2-Way)

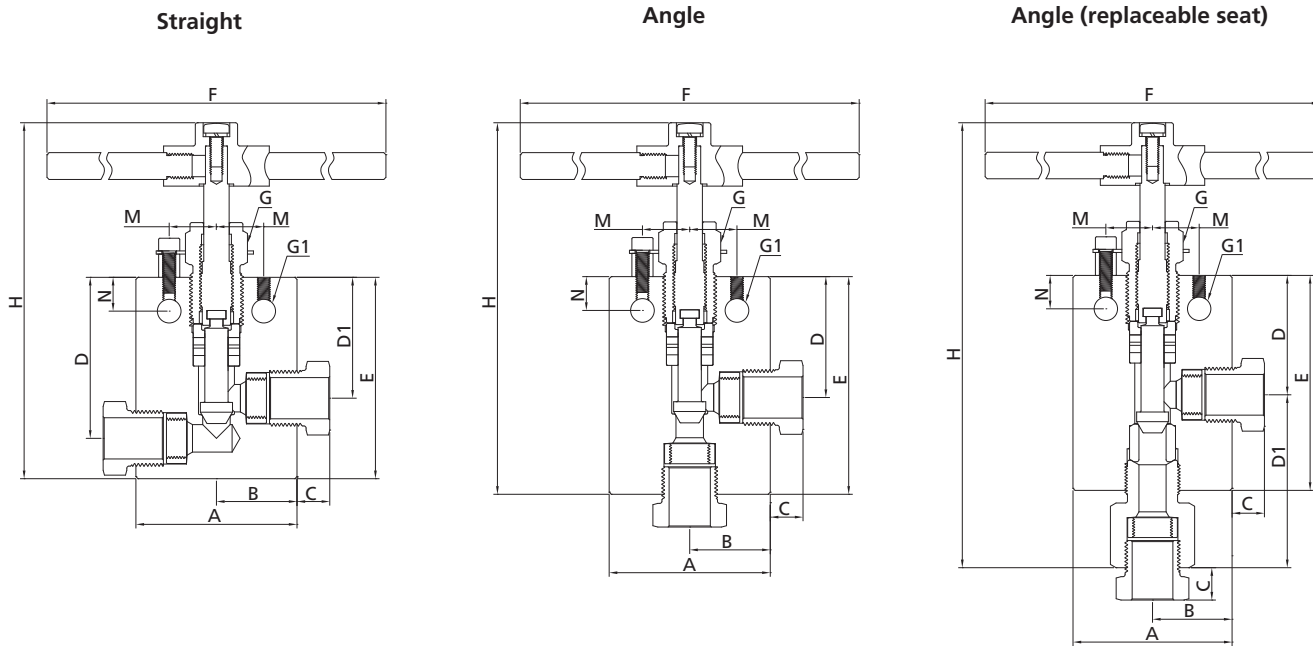

Straight															
Ordering Number	Connection	Orifice in. (mm)	Dimensions, in. (mm)												
			A	B	C	D	D1	E	F	G	G1	H	M	N	Thickness
10NSS-MF9-1	MF9	0.359 (9.12)	2.50 (63.5)	1.25 (31.8)	0.55 (14.0)	2.38 (60.5)	1.75 (44.5)	2.88 (73.2)	4.00 (101.6)	1.00 (25.4)	0.34 (8.6)	6.20 (157.4)	0.69 (17.5)	0.50 (12.7)	1.00 (25.4)
10NSS-MF12-1	MF12	0.516 (13.11)	3.00 (76.2)	1.50 (38.1)	0.60 (15.2)	3.00 (76.2)	2.25 (57.2)	3.75 (95.3)	10.25 (260.4)	1.19 (30.2)	0.44 (11.2)	7.24 (183.8)	0.88 (22.4)	0.63 (16.0)	1.38 (35.1)
10NSS-MF16-1	MF16	0.688 (17.48)	4.12 (104.6)	2.06 (52.3)	0.74 (18.7)	3.75 (95.3)	2.81 (71.4)	4.63 (117.6)	10.25 (260.4)	1.62 (41.2)	0.56 (14.2)	9.33 (237.1)	1.25 (31.8)	1.13 (28.7)	1.75 (44.5)

Angle															
Ordering Number	Connection	Orifice in. (mm)	Dimensions, in. (mm)												
			A	B	C	D	D1	E	F	G	G1	H	M	N	Thickness
10NSS-MF9-2	MF9	0.359 (9.12)	2.50 (63.5)	1.25 (31.8)	0.55 (14.0)	1.75 (44.5)	/	3.38 (85.9)	4.00 (101.6)	1.00 (25.4)	0.34 (8.6)	6.70 (170.3)	0.69 (17.5)	0.50 (12.7)	1.00 (25.4)
10NSS-MF12-2	MF12	0.516 (13.11)	3.00 (76.2)	1.50 (38.1)	0.60 (15.2)	2.25 (57.2)	/	4.25 (107.9)	10.25 (260.4)	1.19 (30.2)	0.44 (11.2)	7.73 (196.4)	0.88 (22.4)	0.63 (16.0)	1.38 (35.1)
10NSS-MF16-2	MF16	0.688 (17.48)	4.12 (104.6)	2.06 (52.3)	0.74 (18.7)	2.81 (71.4)	/	5.12 (130.1)	10.25 (260.4)	1.62 (41.2)	0.56 (14.2)	9.95 (252.6)	1.25 (31.8)	1.13 (28.7)	1.75 (44.5)

Angle (replaceable seat)															
Ordering Number	Connection	Orifice in. (mm)	Dimensions, in. (mm)												
			A	B	C	D	D1	E	F	G	G1	H	M	N	Thickness
10NSS-MF9-3	MF9	0.359 (9.12)	2.50 (63.5)	1.25 (31.8)	0.55 (14.0)	1.75 (44.5)	2.50 (63.5)	3.38 (85.9)	4.00 (101.6)	1.00 (25.4)	0.34 (8.6)	7.57 (192.4)	0.69 (17.5)	0.50 (12.7)	1.00 (25.4)
10NSS-MF12-3	MF12	0.516 (13.11)	3.00 (76.2)	1.50 (38.1)	0.60 (15.2)	2.25 (57.2)	3.19 (81.1)	4.25 (107.9)	10.25 (260.4)	1.19 (30.2)	0.44 (11.2)	8.92 (226.8)	0.88 (22.4)	0.63 (16.0)	1.38 (35.1)
10NSS-MF16-3	MF16	0.688 (17.48)	4.12 (104.6)	2.06 (52.3)	0.74 (18.7)	2.81 (71.4)	4.11 (104.5)	5.25 (133.3)	10.25 (260.4)	1.62 (41.2)	0.56 (14.2)	11.62 (295.4)	1.25 (31.8)	1.13 (28.7)	1.75 (44.5)

Fittings
Tubing
Quick Couplings
Line Filters
Valves
Sour Service Products
Subsea Valves
Tools and Installation Instructions
Technical Information
Part Number Crossover Charts

Ordering Information and Dimensions (Tubing Connection, 3-Way)

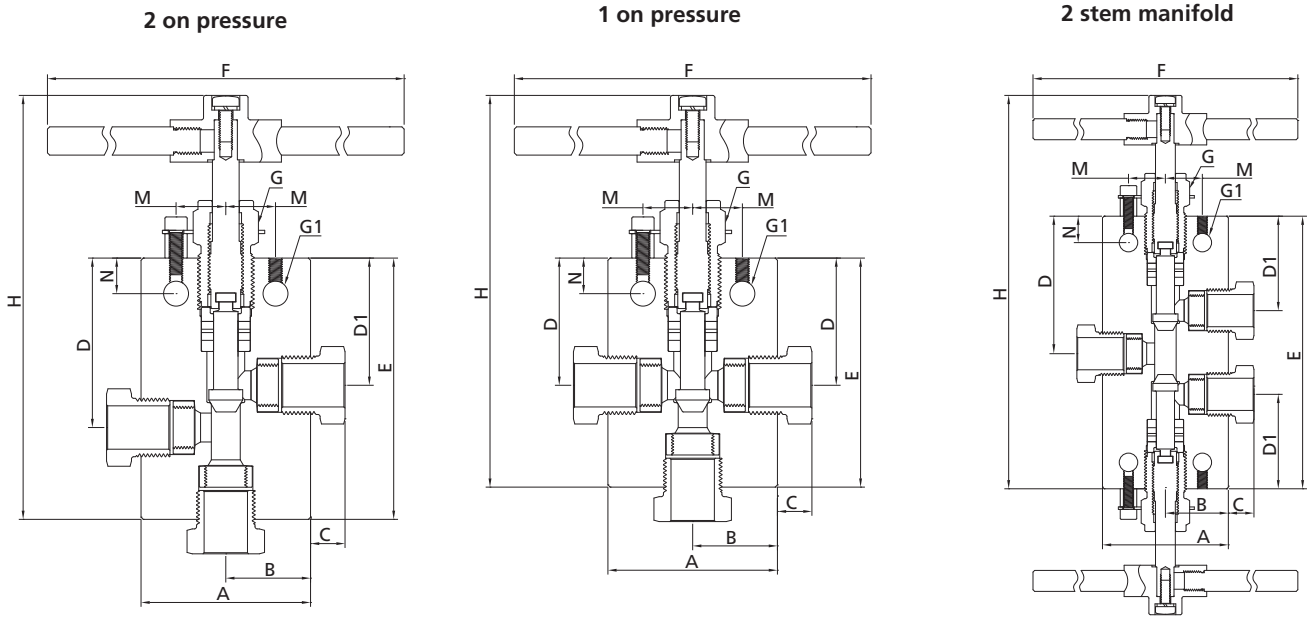

2 on pressure

Ordering Number	Connection	Orifice in. (mm)	Dimensions, in. (mm)												
			A	B	C	D	D1	E	F	G	G1	H	M	N	Thickness
10NSS-MF9-4	MF9	0.359 (9.12)	2.50 (63.5)	1.25 (31.8)	0.55 (14.0)	2.38 (60.5)	1.75 (44.5)	3.63 (92.1)	4.00 (101.6)	1.00 (25.4)	0.34 (8.6)	6.95 (176.5)	0.69 (17.5)	0.50 (12.7)	1.00 (25.4)
10NSS-MF12-4	MF12	0.516 (13.11)	3.00 (76.2)	1.50 (38.1)	0.60 (15.2)	3.00 (76.2)	2.25 (57.2)	4.63 (117.5)	10.25 (260.4)	1.19 (30.2)	0.44 (11.2)	8.11 (206.0)	0.88 (22.4)	0.63 (16.0)	1.38 (35.1)
10NSS-MF16-4	MF16	0.688 (17.48)	4.12 (104.6)	2.06 (52.3)	0.74 (18.7)	3.75 (95.3)	2.81 (71.4)	5.88 (149.4)	10.25 (260.4)	1.62 (41.2)	0.56 (14.2)	10.58 (268.7)	1.25 (31.8)	1.13 (28.7)	1.75 (44.5)

1 on pressure

Ordering Number	Connection	Orifice in. (mm)	Dimensions, in. (mm)												
			A	B	C	D	D1	E	F	G	G1	H	M	N	Thickness
10NSS-MF9-5	MF9	0.359 (9.12)	2.50 (63.5)	1.25 (31.8)	0.55 (14.0)	1.75 (44.5)	/	3.38 (85.9)	4.00 (101.6)	1.00 (25.4)	0.34 (8.6)	6.70 (170.3)	0.69 (17.5)	0.50 (12.7)	1.00 (25.4)
10NSS-MF12-5	MF12	0.516 (13.11)	3.00 (76.2)	1.50 (38.1)	0.60 (15.2)	2.25 (57.2)	/	4.25 (107.9)	10.25 (260.4)	1.19 (30.2)	0.44 (11.2)	7.73 (196.4)	0.88 (22.4)	0.63 (16.0)	1.38 (35.1)
10NSS-MF16-5	MF16	0.688 (17.48)	4.12 (104.6)	2.06 (52.3)	0.74 (18.7)	2.81 (71.4)	/	5.12 (130.1)	10.25 (260.4)	1.62 (41.2)	0.56 (14.2)	9.95 (252.6)	1.25 (31.8)	1.13 (28.7)	1.75 (44.5)

2 stem manifold

Ordering Number	Connection	Orifice in. (mm)	Dimensions, in. (mm)												
			A	B	C	D	D1	E	F	G	G1	H	M	N	Thickness
10NSS-MF9-6	MF9	0.359 (9.12)	2.50 (63.5)	1.25 (31.8)	0.55 (14.0)	2.56 (65.1)	1.75 (44.5)	5.13 (130.2)	4.00 (101.6)	1.00 (25.4)	0.34 (8.6)	8.45 (214.6)	0.69 (17.5)	0.50 (12.7)	1.00 (25.4)
10NSS-MF12-6	MF12	0.516 (13.11)	3.00 (76.2)	1.50 (38.1)	0.60 (15.2)	3.25 (82.6)	2.25 (57.2)	6.50 (165.1)	10.25 (260.4)	1.19 (30.2)	0.44 (11.2)	9.98 (253.5)	0.88 (22.4)	0.63 (16.0)	1.38 (35.1)
10NSS-MF16-6	MF16	0.688 (17.48)	4.12 (104.6)	2.06 (52.3)	0.74 (18.7)	3.75 (95.3)	2.81 (71.4)	7.50 (190.5)	10.25 (260.4)	1.62 (41.2)	0.56 (14.2)	12.20 (310.1)	1.25 (31.8)	1.13 (28.7)	1.75 (44.5)

Ordering Information and Dimensions (Pipe Connection, 2-Way)

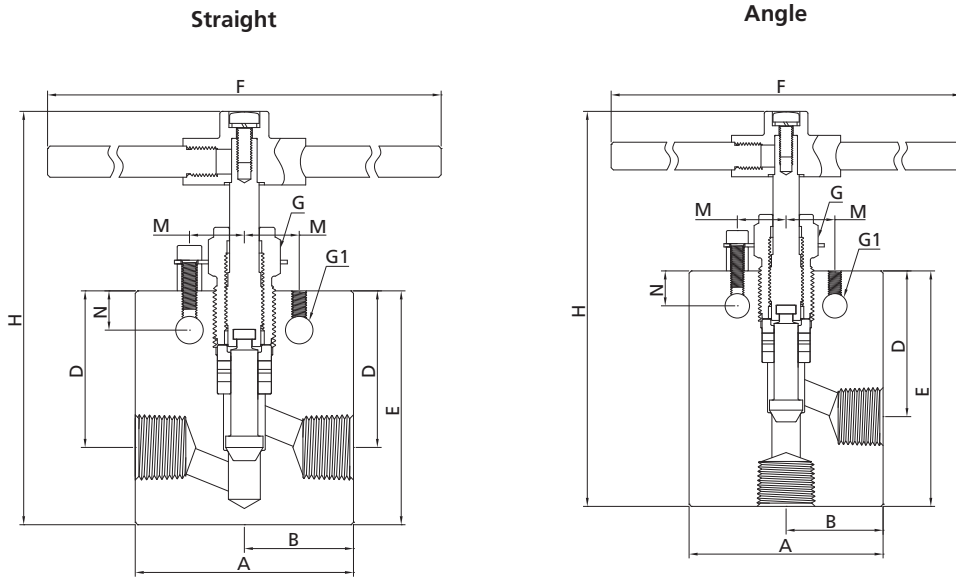

Straight															
Ordering Number	Connection	Orifice in. (mm)	Dimensions, in. (mm)												
			A	B	C	D	D1	E	F	G	G1	H	M	N	Thickness
10NSS-FNS12-1	FNS12	0.437 (11.10)	3.50 (88.9)	1.75 (44.5)	/	2.63 (66.8)	/	3.75 (95.3)	10.25 (260.4)	1.19 (30.2)	0.44 (11.2)	7.42 (188.6)	0.88 (22.4)	0.63 (16.0)	1.75 (44.5)
10NSS-FRT12-1	FRT12		4.12 (104.6)	2.06 (52.3)	/	3.31 (84.1)	/	4.62 (117.4)	10.25 (260.4)	1.62 (41.2)	0.56 (14.2)	9.45 (240.1)	1.25 (31.8)	1.13 (28.7)	1.75 (44.5)
10NSS-FNS16-1	FNS16	0.562 (14.27)	4.12 (104.6)	2.06 (52.3)	/	3.31 (84.1)	/	4.62 (117.4)	10.25 (260.4)	1.62 (41.2)	0.56 (14.2)	9.45 (240.1)	1.25 (31.8)	1.13 (28.7)	1.75 (44.5)
10NSS-FRT16-1	FRT16		4.12 (104.6)	2.06 (52.3)	/	3.31 (84.1)	/	4.62 (117.4)	10.25 (260.4)	1.62 (41.2)	0.56 (14.2)	9.45 (240.1)	1.25 (31.8)	1.13 (28.7)	1.75 (44.5)

Angle															
Ordering Number	Connection	Orifice in. (mm)	Dimensions, in. (mm)												
			A	B	C	D	D1	E	F	G	G1	H	M	N	Thickness
10NSS-FNS12-2	FNS12	0.437 (11.10)	3.50 (88.9)	1.75 (44.5)	/	2.63 (66.8)	/	4.25 (107.9)	10.25 (260.4)	1.19 (30.2)	0.44 (11.2)	7.92 (201.3)	0.88 (22.4)	0.63 (16.0)	1.75 (44.5)
10NSS-FRT12-2	FRT12		4.12 (104.6)	2.06 (52.3)	/	3.31 (84.1)	/	5.12 (130.1)	10.25 (260.4)	1.64 (41.2)	0.56 (14.2)	9.94 (252.5)	1.25 (31.8)	1.13 (28.7)	1.75 (44.5)
10NSS-FNS16-2	FNS16	0.562 (14.27)	4.12 (104.6)	2.06 (52.3)	/	3.31 (84.1)	/	5.12 (130.1)	10.25 (260.4)	1.64 (41.2)	0.56 (14.2)	9.94 (252.5)	1.25 (31.8)	1.13 (28.7)	1.75 (44.5)
10NSS-FRT16-2	FRT16		4.12 (104.6)	2.06 (52.3)	/	3.31 (84.1)	/	5.12 (130.1)	10.25 (260.4)	1.64 (41.2)	0.56 (14.2)	9.94 (252.5)	1.25 (31.8)	1.13 (28.7)	1.75 (44.5)

Fittings
Tubing
Quick Couplings
Line Filters
Valves
Sour Service Products
Subsea Valves
Tools and Installation Instructions
Technical Information
Part Number Crossover Charts

Ordering Information and Dimensions (Pipe Connection, 3-Way)

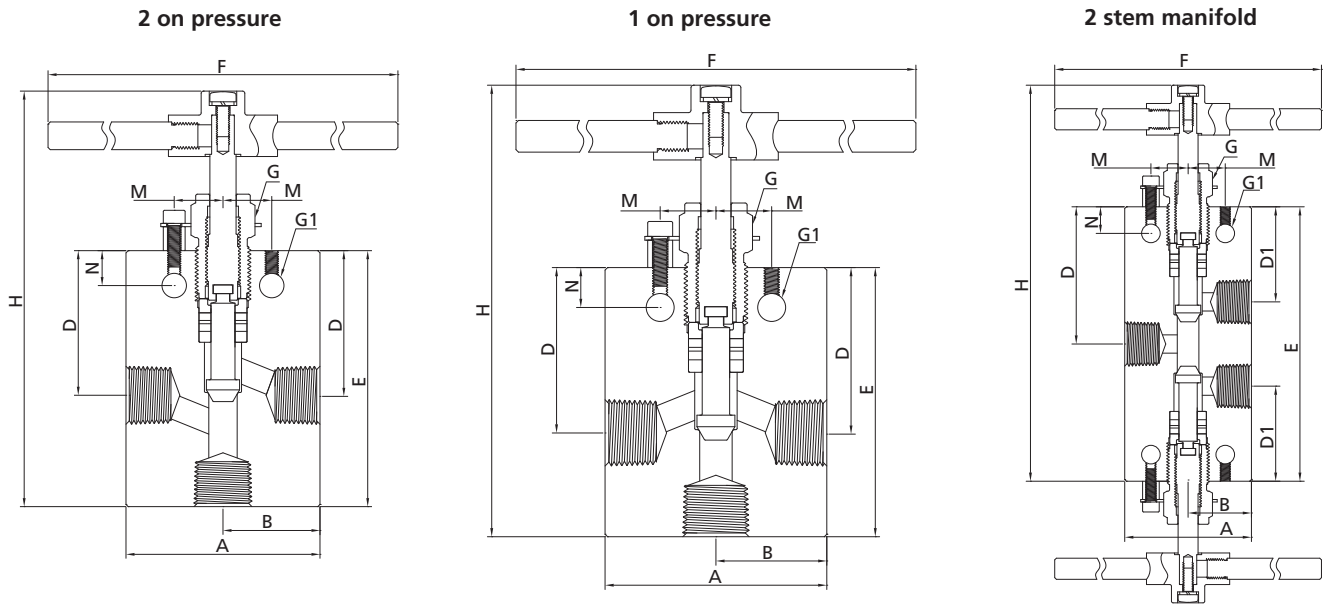

2 on pressure															
Ordering Number	Connection	Orifice in. (mm)	Dimensions, in. (mm)												
			A	B	C	D	D1	E	F	G	G1	H	M	N	Thickness
10NSS-FNS12-4	FNS12	0.437 (11.10)	3.50 (88.9)	1.75 (44.5)	/	2.63 (66.8)	/	4.62 (117.4)	10.25 (260.4)	1.19 (30.2)	0.44 (11.2)	8.40 (213.4)	0.88 (22.4)	0.63 (16.0)	1.75 (44.5)
10NSS-FRT12-4	FRT12														
10NSS-FNS16-4	FNS16	0.562 (14.27)	4.12 (104.6)	2.06 (52.3)	/	3.31 (84.1)	/	5.88 (149.4)	10.25 (260.4)	1.64 (41.2)	0.56 (14.2)	10.70 (271.7)	1.25 (31.8)	1.13 (28.7)	1.75 (44.5)
10NSS-FRT16-4	FRT16														

1 on pressure															
Ordering Number	Connection	Orifice in. (mm)	Dimensions, in. (mm)												
			A	B	C	D	D1	E	F	G	G1	H	M	N	Thickness
10NSS-FNS12-5	FNS12	0.437 (11.10)	3.50 (88.9)	1.75 (44.5)	/	2.63 (66.8)	/	4.25 (107.9)	10.25 (260.4)	1.19 (30.2)	0.44 (11.2)	7.92 (201.3)	0.88 (22.4)	0.63 (16.0)	1.75 (44.5)
10NSS-FRT12-5	FRT12														
10NSS-FNS16-5	FNS16	0.562 (14.27)	4.12 (104.6)	2.06 (52.3)	/	3.31 (84.1)	/	5.12 (130.1)	10.25 (260.4)	1.62 (41.2)	0.56 (14.2)	9.94 (252.5)	1.25 (31.8)	1.13 (28.7)	1.75 (44.5)
10NSS-FRT16-5	FRT16														

2 stem manifold															
Ordering Number	Connection	Orifice in. (mm)	Dimensions, in. (mm)												
			A	B	C	D	D1	E	F	G	G1	H	M	N	Thickness
10NSS-FNS12-6	FNS12	0.437 (11.10)	3.50 (88.9)	1.75 (44.5)	/	3.25 (82.6)	2.25 (57.2)	6.50 (165.1)	10.25 (260.4)	1.19 (30.2)	0.44 (11.2)	10.28 (261.2)	0.88 (22.4)	0.63 (16.0)	1.75 (44.5)
10NSS-FRT12-6	FRT12														
10NSS-FNS16-6	FNS16	0.562 (14.27)	4.12 (104.6)	2.06 (52.3)	/	3.75 (95.3)	2.81 (71.42)	7.50 (190.5)	10.25 (260.4)	1.62 (41.2)	0.56 (14.2)	12.32 (313.0)	1.25 (31.8)	1.13 (28.7)	1.75 (44.5)
10NSS-FRT16-6	FRT16														

- NOTES: 1. G is the drill dimension of packing gland mounting hole.
 2. G1 is the dimension of bracket mounting hole.
 3. Panel mounting drill size: 0.25" all valves.
 4. H is the dimension of stem in closed position.
 5. All dimensions for reference only and subject to change. For dimensions not shown above, please contact FITOK group or our authorized distributors.

15N Series: 15,000 psig (1034 bar)

Features

- ⦿ High tensile 316 Stainless Steel for valve body and S17400 Stainless Steel for lower stem
- ⦿ Metal-to-metal seating achieves ideal shutoff, longer stem/seat service lifetime for abrasive flow, excellent corrosion resistance and greater durability for repeated on/off cycles
- ⦿ Non-rotating stem and bar stock body design
- ⦿ Easy to assemble and replace packing
- ⦿ Reliable locking for packing gland
- ⦿ Options for Vee or Regulating stem tips
- ⦿ Five flow patterns available

Technical Data

Connection Size	Connection	Orifice in. (mm)	Cv	Working Pressure psig (bar)	Working Temperature Range
1/8" Female 20D Series Tube Fitting	DFF2	0.094 (2.39)	0.12	15, 000 (1034)	-100°F~800°F (-73°C~427°C)
1/4" Female 20D Series Tube Fitting	DFF4	0.188 (4.77)	0.65	15, 000 (1034)	
3/8" Female 20D Series Tube Fitting	DFF6	0.250 (6.35)	0.95	15, 000 (1034)	
1/2" Female 20D Series Tube Fitting	DFF8	0.375 (9.53)	1.90	15, 000 (1034)	
1/8" Female NPT	FNS2	0.078 (1.98)	0.11	15, 000 (1034)	-100°F~400°F (-73°C~204°C)
1/8" Female ISO Tapered Thread	FRT2				
1/4" Female NPT	FNS4	0.203 (5.16)	0.63	15, 000 (1034)	
1/4" Female ISO Tapered Thread	FRT4				
3/8" Female NPT	FNS6	0.219 (5.56)	0.75	15, 000 (1034)	
3/8" Female ISO Tapered Thread	FRT6				
1/2" Female NPT	FNS8	0.312 (7.92)	1.30	15, 000 (1034)	
1/2" Female ISO Tapered Thread	FRT8				

NOTES: 1. Cv values shown are for 2-way straight valve pattern. For 2-way angle pattern, increase Cv value by 50% (Based on water).

2. Packing Options

PTFE is the standard packing material, RPTFE glass and Graphite also available. Graphite packing not recommended for Hydrogen or Helium service.

PTFE: -100°F~450°F (-73°C~232°C)

RPTFE glass: -100°F~600°F (-73°C~316°C)

Graphite: 0°F~800°F (-17.8°C~427°C)

Fittings

Tubing

Quick Couplings

Line Filters

Valves

Sour Service Products

Subsea Valves

Tools and Installation Instructions

Technical Information

Part Number Crossover Charts

Flow Data at 100°F (38°C)

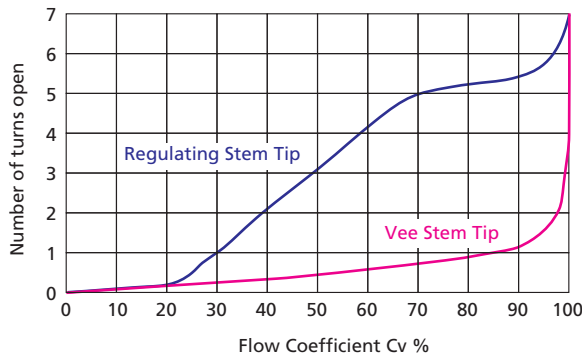

Pressure vs. Temperature Curve

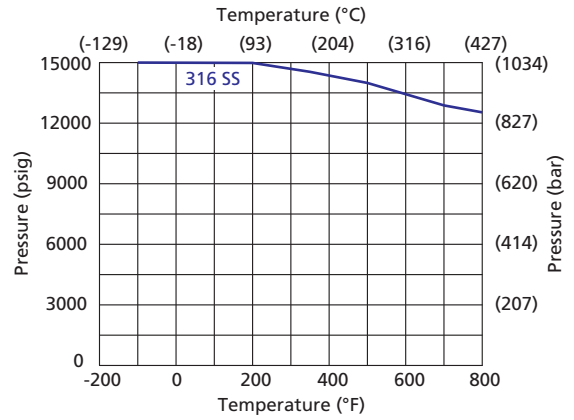

Standard Materials of Construction

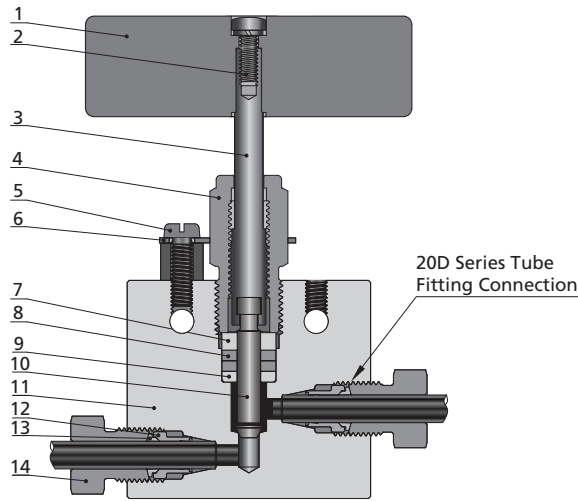

Item	Component	Material Grade
1	Handle	Stainless steel
2	Handle Screw	Stainless steel
3	Upper Stem	316 SS
4	Packing Gland	C63000
5	Locking Screw	Stainless steel
6	Locking Plate	304 SS
7	Packing Ring	C63000
8	<i>Packing</i>	<i>PTFE/RPTFE/Graphite</i>
9	<i>Packing Washer</i>	<i>S17400</i>
10	<i>Lower Stem</i>	<i>S17400</i>
11	Body	316 SS
12	<i>Front Ferrule</i>	<i>316 SS (For tubing connections)</i>
13	Rear Ferrule	316 SS (For tubing connections)
14	Nut	316 SS (For tubing connections)
	Lubricant	Molybdenum disulfide

Wetted component listed in italics.

- Fittings
- Tubing
- Quick Couplings
- Line Filters
- Valves
- Sour Service Products
- Subsea Valves
- Tools and Installation Instructions
- Technical Information
- Part Number Crossover Charts

Ordering Information and Dimensions (Tubing Connection, 2-Way)

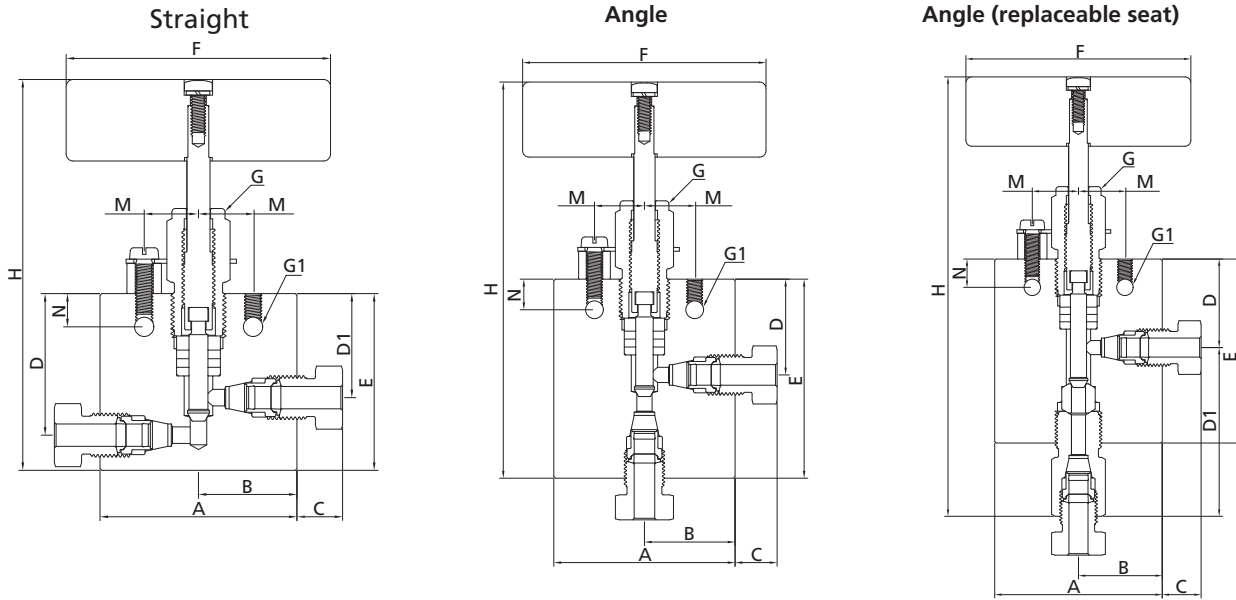

Straight															
Ordering Number	Connection	Orifice in. (mm)	Dimensions, in. (mm)												
			A	B	C	D	D1	E	F	G	G1	H	M	N	Thickness
15NSS-DFF2-1	DFF2	0.094 (2.39)	1.81 (46.1)	0.91 (23.1)	0.44 (11.2)	1.06 (27.0)	0.81 (20.6)	1.38 (35.0)	1.75 (44.5)	0.62 (15.8)	0.17 (4.3)	3.13 (79.6)	0.56 (14.2)	0.31 (7.9)	0.62 (15.8)
15NSS-DFF4-1	DFF4	0.188 (4.77)	2.33 (59.2)	1.17 (29.6)	0.52 (13.3)	1.62 (41.2)	1.19 (30.2)	2.00 (50.8)	3.00 (76.2)	0.75 (19.1)	0.22 (5.6)	4.90 (124.5)	0.62 (15.8)	0.38 (9.7)	0.75 (19.1)
15NSS-DFF6-1	DFF6	0.250 (6.35)	2.27 (57.6)	1.13 (28.8)	0.54 (13.6)	1.62 (41.2)	1.19 (30.2)	2.00 (50.8)	3.00 (76.2)	0.75 (19.1)	0.22 (5.6)	4.97 (126.3)	0.62 (15.8)	0.38 (9.7)	0.75 (19.1)
15NSS-DFF8-1	DFF8	0.375 (9.53)	2.86 (72.7)	1.43 (36.4)	0.60 (15.3)	2.37 (60.3)	1.75 (44.5)	2.88 (73.2)	4.00 (101.6)	1.00 (25.4)	0.34 (8.6)	6.21 (157.7)	0.69 (17.5)	0.50 (12.7)	1.00 (25.4)

Angle															
Ordering Number	Connection	Orifice in. (mm)	Dimensions, in. (mm)												
			A	B	C	D	D1	E	F	G	G1	H	M	N	Thickness
15NSS-DFF2-2	DFF2	0.094 (2.39)	1.81 (46.1)	0.91 (23.1)	0.44 (11.2)	0.81 (20.6)	/	1.72 (43.6)	1.75 (44.5)	0.62 (15.8)	0.17 (4.3)	3.47 (88.2)	0.56 (14.2)	0.31 (7.9)	0.62 (15.8)
15NSS-DFF4-2	DFF4	0.188 (4.77)	2.33 (59.2)	1.17 (29.6)	0.52 (13.3)	1.19 (30.2)	/	2.60 (66.0)	3.00 (76.2)	0.75 (19.1)	0.22 (5.6)	5.50 (139.7)	0.62 (15.8)	0.38 (9.7)	0.75 (19.1)
15NSS-DFF6-2	DFF6	0.250 (6.35)	2.27 (57.6)	1.13 (28.8)	0.54 (13.6)	1.19 (30.2)	/	2.56 (65.0)	3.00 (76.2)	0.75 (19.1)	0.22 (5.6)	5.53 (140.5)	0.62 (15.8)	0.38 (9.7)	0.75 (19.1)
15NSS-DFF8-2	DFF8	0.375 (9.53)	2.86 (72.7)	1.43 (36.4)	0.60 (15.3)	1.75 (44.5)	/	3.56 (90.5)	4.00 (101.6)	1.00 (25.4)	0.34 (8.6)	6.89 (175.0)	0.69 (17.5)	0.50 (12.7)	1.00 (25.4)

Angle (replaceable seat)															
Ordering Number	Connection	Orifice in. (mm)	Dimensions, in. (mm)												
			A	B	C	D	D1	E	F	G	G1	H	M	N	Thickness
15NSS-DFF2-3	DFF2	0.094 (2.39)	1.81 (46.1)	0.91 (23.1)	0.44 (11.2)	0.81 (20.6)	1.44 (36.5)	1.56 (39.7)	1.75 (44.5)	0.62 (15.8)	0.17 (4.3)	4.00 (101.6)	0.56 (14.2)	0.31 (7.9)	0.62 (15.8)
15NSS-DFF4-3	DFF4	0.188 (4.77)	2.33 (59.2)	1.17 (29.6)	0.52 (13.3)	1.19 (30.2)	2.05 (52.0)	2.25 (57.2)	3.00 (76.2)	0.75 (19.1)	0.22 (5.6)	6.13 (155.8)	0.62 (15.8)	0.38 (9.7)	0.75 (19.1)
15NSS-DFF6-3	DFF6	0.250 (6.35)	2.27 (57.6)	1.13 (28.8)	0.54 (13.6)	1.19 (30.2)	2.32 (59.0)	2.25 (57.2)	3.00 (76.2)	0.75 (19.1)	0.22 (5.6)	6.48 (164.7)	0.62 (15.8)	0.38 (9.7)	0.75 (19.1)
15NSS-DFF8-3	DFF8	0.375 (9.53)	2.86 (72.7)	1.43 (36.4)	0.60 (15.3)	1.75 (44.5)	2.68 (68.1)	3.25 (82.6)	4.00 (101.6)	1.00 (25.4)	0.34 (8.6)	7.72 (196.1)	0.69 (17.5)	0.50 (12.7)	1.00 (25.4)

Fittings
Tubing
Quick Couplings
Line Filters
Valves
Sour Service Products
Subsea Valves
Tools and Installation Instructions
Technical Information
Part Number Crossover Charts

Ordering Information and Dimensions (Tubing Connection, 3-Way)

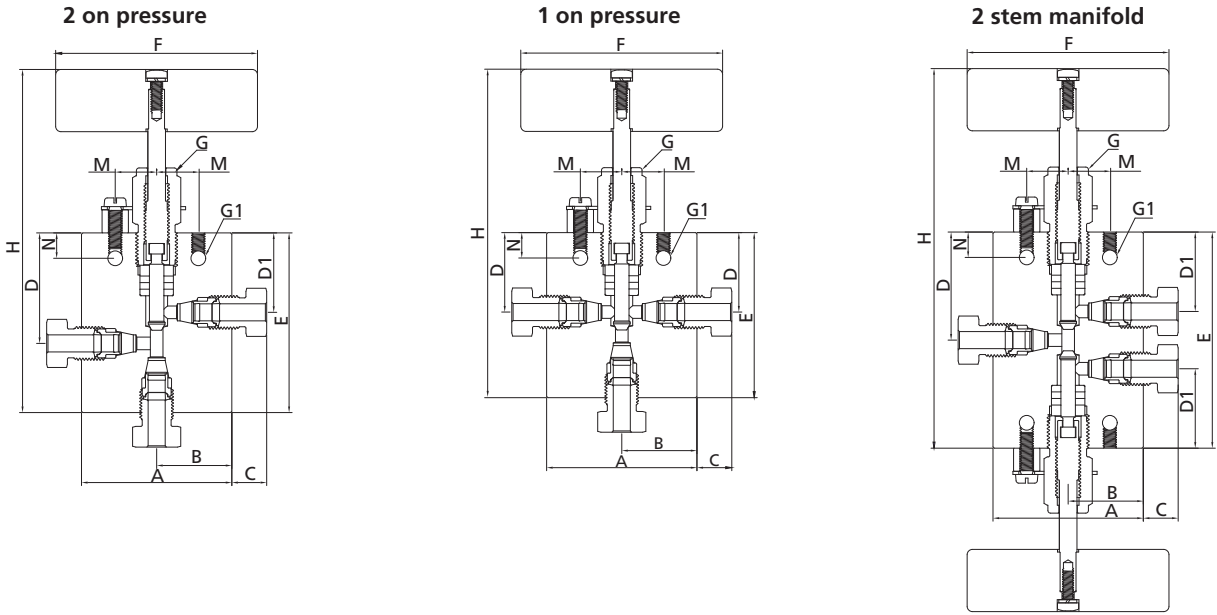

2 on pressure

Ordering Number	Connection	Orifice in. (mm)	Dimensions, in. (mm)												
			A	B	C	D	D1	E	F	G	G1	H	M	N	Thickness
15NSS-DFF2-4	DFF2	0.094 (2.39)	1.81 (46.1)	0.91 (23.1)	0.44 (11.2)	1.06 (27.0)	0.81 (20.6)	1.85 (46.9)	1.75 (44.5)	0.62 (15.8)	0.17 (4.3)	3.60 (91.5)	0.56 (14.2)	0.31 (7.9)	0.62 (15.8)
15NSS-DFF4-4	DFF4	0.188 (4.77)	2.33 (59.2)	1.17 (29.6)	0.52 (13.3)	1.62 (41.2)	1.19 (30.2)	2.79 (70.8)	3.00 (76.2)	0.75 (19.1)	0.22 (5.6)	5.56 (144.5)	0.62 (15.8)	0.38 (9.7)	0.75 (19.1)
15NSS-DFF6-4	DFF6	0.250 (6.35)	2.27 (57.6)	1.13 (28.8)	0.54 (13.6)	1.62 (41.2)	1.19 (30.2)	2.76 (70.0)	3.00 (76.2)	0.75 (19.1)	0.22 (5.6)	5.73 (145.5)	0.62 (15.8)	0.38 (9.7)	0.75 (19.1)
15NSS-DFF8-4	DFF8	0.375 (9.53)	2.86 (72.7)	1.43 (36.4)	0.60 (15.3)	2.37 (60.3)	1.75 (44.5)	3.80 (96.6)	4.00 (101.6)	1.00 (25.4)	0.34 (8.6)	7.14 (181.3)	0.69 (17.5)	0.50 (12.7)	1.00 (25.4)

1 on pressure

Ordering Number	Connection	Orifice in. (mm)	Dimensions, in. (mm)												
			A	B	C	D	D1	E	F	G	G1	H	M	N	Thickness
15NSS-DFF2-5	DFF2	0.094 (2.39)	1.81 (46.1)	0.91 (23.1)	0.44 (11.2)	0.81 (20.6)	/	1.72 (43.6)	1.75 (44.5)	0.62 (15.8)	0.17 (4.3)	3.47 (88.2)	0.56 (14.2)	0.31 (7.9)	0.62 (15.8)
15NSS-DFF4-5	DFF4	0.188 (4.77)	2.33 (59.2)	1.17 (29.6)	0.52 (13.3)	1.19 (30.2)	/	2.60 (66.0)	3.00 (76.2)	0.75 (19.1)	0.22 (5.6)	5.50 (139.7)	0.62 (15.8)	0.38 (9.7)	0.75 (19.1)
15NSS-DFF6-5	DFF6	0.250 (6.35)	2.27 (57.6)	1.13 (28.8)	0.54 (13.6)	1.19 (30.2)	/	2.56 (65.0)	3.00 (76.2)	0.75 (19.1)	0.22 (5.6)	5.53 (140.5)	0.62 (15.8)	0.38 (9.7)	0.75 (19.1)
15NSS-DFF8-5	DFF8	0.375 (9.53)	2.86 (72.7)	1.43 (36.4)	0.60 (15.3)	1.75 (44.5)	/	3.56 (90.5)	4.00 (101.6)	1.00 (25.4)	0.34 (8.6)	6.89 (175.0)	0.69 (17.5)	0.50 (12.7)	1.00 (25.4)

2 stem manifold

Ordering Number	Connection	Orifice in. (mm)	Dimensions, in. (mm)												
			A	B	C	D	D1	E	F	G	G1	H	M	N	Thickness
15NSS-DFF2-6	DFF2	0.094 (2.39)	1.81 (46.1)	0.91 (23.1)	0.44 (11.2)	1.13 (28.6)	0.81 (20.6)	2.25 (57.2)	1.75 (44.5)	0.62 (15.8)	0.17 (4.3)	4.00 (101.8)	0.56 (14.2)	0.31 (7.9)	0.62 (15.8)
15NSS-DFF4-6	DFF4	0.188 (4.77)	2.33 (59.2)	1.17 (29.6)	0.52 (13.3)	1.69 (42.9)	1.19 (30.2)	3.38 (85.8)	3.00 (76.2)	0.75 (19.1)	0.22 (5.6)	6.28 (159.6)	0.62 (15.8)	0.38 (9.7)	0.75 (19.1)
15NSS-DFF6-6	DFF6	0.250 (6.35)	2.27 (57.6)	1.13 (28.8)	0.54 (13.6)	1.69 (42.9)	1.19 (30.2)	3.38 (85.8)	3.00 (76.2)	0.75 (19.1)	0.22 (5.6)	6.35 (161.3)	0.62 (15.8)	0.38 (9.7)	0.75 (19.1)
15NSS-DFF8-6	DFF8	0.375 (9.53)	2.86 (72.7)	1.43 (36.4)	0.60 (15.3)	2.56 (65.1)	1.75 (44.5)	5.13 (130.2)	4.00 (101.6)	1.00 (25.4)	0.34 (8.6)	8.45 (214.7)	0.69 (17.5)	0.50 (12.7)	1.00 (25.4)

Ordering Information and Dimensions (Pipe Connection, 2-Way)

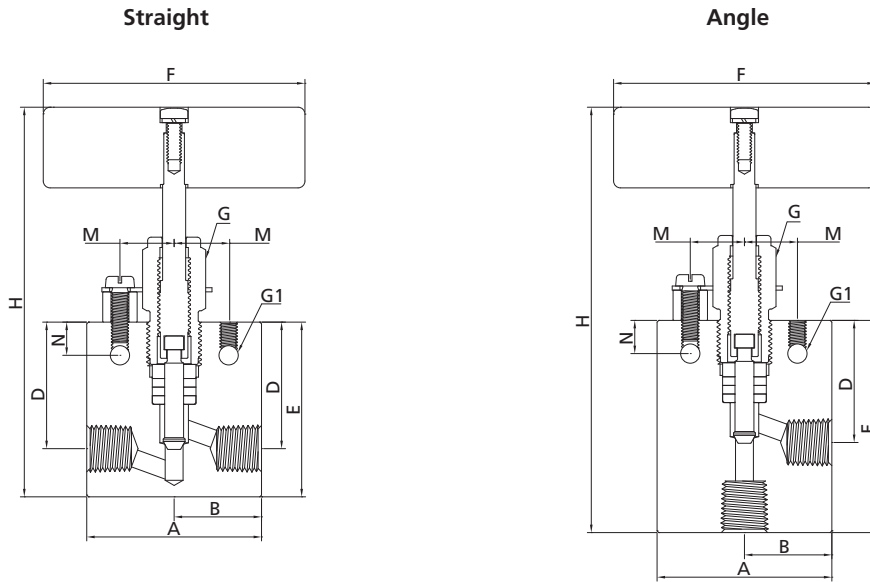

Straight															
Ordering Number	Connection	Orifice in. (mm)	Dimensions, in. (mm)												
			A	B	C	D	D1	E	F	G	G1	H	M	N	Thickness
15NSS-FNS2-1	FNS2	0.078 (1.98)	1.50 (38.1)	0.75 (19.1)	/	0.82 (20.6)	/	1.25 (31.8)	1.75 (44.5)	0.62 (15.8)	0.17 (4.3)	3.00 (76.4)	0.56 (14.2)	0.31 (7.9)	0.63 (15.9)
15NSS-FRT2-1	FRT2														
15NSS-FNS4-1	FNS4	0.203 (5.2)	2.00 (50.8)	1.00 (25.4)	/	1.41 (35.8)	/	2.00 (50.8)	3.00 (76.2)	0.75 (19.1)	0.22 (5.6)	4.89 (124.1)	0.62 (15.8)	0.38 (9.7)	0.75 (19.1)
15NSS-FRT4-1	FRT4														
15NSS-FNS6-1	FNS6	0.219 (5.56)	2.50 (63.5)	1.25 (31.8)	/	1.41 (35.8)	/	2.00 (50.8)	3.00 (76.2)	0.75 (19.1)	0.22 (5.6)	4.82 (122.5)	0.62 (15.8)	0.38 (9.7)	1.00 (25.4)
15NSS-FRT6-1	FRT6														
15NSS-FNS8-1	FNS8	0.312 (7.92)	3.00 (76.2)	1.50 (38.1)	/	2.06 (52.3)	/	2.88 (73.2)	4.00 (101.6)	1.00 (25.4)	0.34 (8.6)	6.18 (157.2)	0.69 (17.5)	0.50 (12.7)	1.38 (35.1)
15NSS-FRT8-1	FRT8														

Angle															
Ordering Number	Connection	Orifice in. (mm)	Dimensions, in. (mm)												
			A	B	C	D	D1	E	F	G	G1	H	M	N	Thickness
15NSS-FNS2-2	FNS2	0.078 (1.98)	1.50 (38.1)	0.75 (19.1)	/	0.81 (20.6)	/	1.38 (34.9)	1.75 (44.5)	0.62 (15.8)	0.17 (4.3)	3.13 (79.5)	0.56 (14.2)	0.31 (7.9)	0.63 (15.9)
15NSS-FRT2-2	FRT2														
15NSS-FNS4-2	FNS4	0.203 (5.2)	2.00 (50.8)	1.00 (25.4)	/	1.41 (35.8)	/	2.44 (62.0)	3.00 (76.2)	0.75 (19.1)	0.22 (5.6)	5.33 (135.4)	0.62 (15.8)	0.38 (9.7)	0.75 (19.1)
15NSS-FRT4-2	FRT4														
15NSS-FNS6-2	FNS6	0.219 (5.56)	2.50 (63.5)	1.25 (31.8)	/	1.41 (35.8)	/	2.44 (62.0)	3.00 (76.2)	0.75 (19.1)	0.22 (5.6)	5.34 (135.7)	0.62 (15.8)	0.38 (9.7)	1.00 (25.4)
15NSS-FRT6-2	FRT6														
15NSS-FNS8-2	FNS8	0.312 (7.92)	3.00 (76.2)	1.50 (38.1)	/	2.06 (52.3)	/	3.38 (85.9)	4.00 (101.6)	1.00 (25.4)	0.34 (8.6)	6.69 (169.9)	0.69 (17.5)	0.50 (12.7)	1.38 (35.1)
15NSS-FRT8-2	FRT8														

Ordering Information and Dimensions (Pipe Connection, 2-Way)	Fittings
	Tubing
	Quick Couplings
	Line Filters
	Valves
	Sour Service Products
	Subsea Valves
	Tools and Installation Instructions
	Technical Information
	Part Number Crossover Charts

Ordering Information and Dimensions (Pipe Connection, 3-Way)

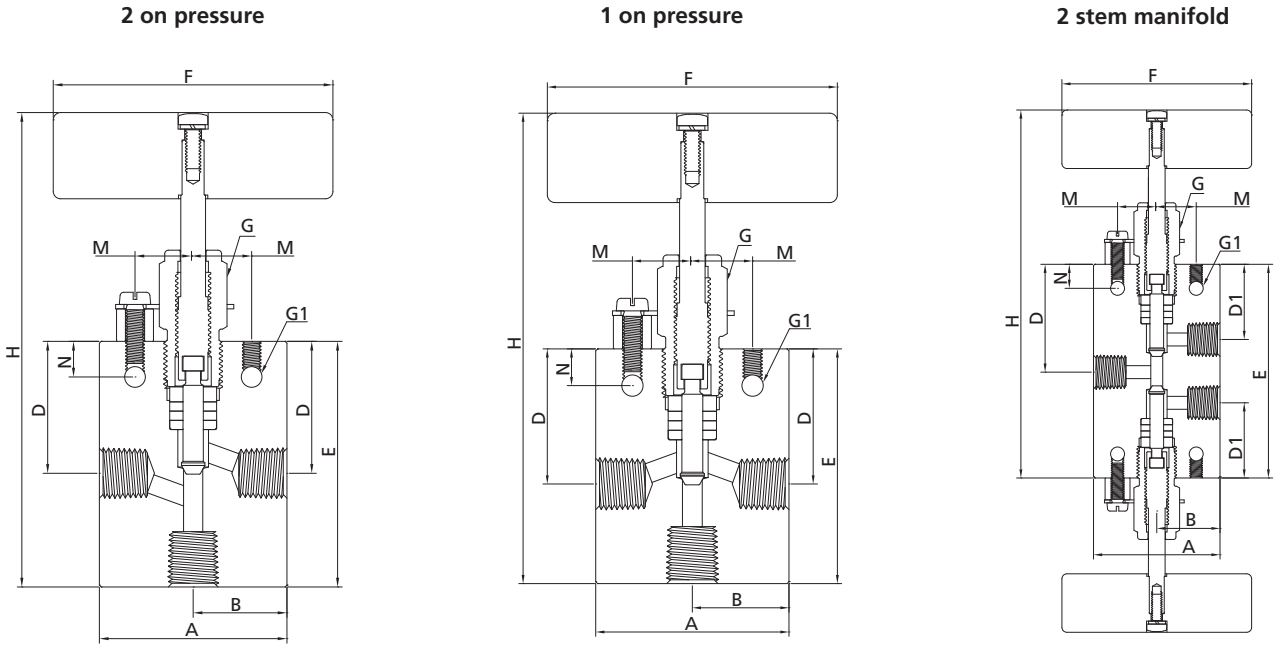

2 on pressure															
Ordering Number	Connection	Orifice in. (mm)	Dimensions, in. (mm)												
			A	B	C	D	D1	E	F	G	G1	H	M	N	Thickness
15NSS-FNS2-4	FNS2	0.078 (1.98)	1.50	0.75	/	0.82	/	1.57	1.75	0.62	0.17	3.33	0.56	0.31	0.63
15NSS-FRT2-4	FRT2		(38.1)	(19.1)		(20.6)		(40.0)	(44.5)	(15.8)	(4.3)	(84.6)	(14.2)	(7.9)	(15.9)
15NSS-FNS4-4	FNS4	0.203 (5.2)	2.00	1.00	/	1.41	/	2.62	3.00	0.75	0.22	5.51	0.62	0.38	0.75
15NSS-FRT4-4	FRT4		(50.8)	(25.4)		(35.8)		(66.6)	(76.2)	(19.1)	(5.6)	(140.0)	(15.8)	(9.7)	(19.1)
15NSS-FNS6-4	FNS6	0.219 (5.56)	2.50	1.25	/	1.41	/	2.62	3.00	0.75	0.22	5.47	0.62	0.38	1.00
15NSS-FRT6-4	FRT6		(63.5)	(31.8)		(35.8)		(66.6)	(76.2)	(19.1)	(5.6)	(138.9)	(15.8)	(9.7)	(25.4)
15NSS-FNS8-4	FNS8	0.312 (7.92)	3.00	1.50	/	2.06	/	3.62	4.00	1.00	0.34	6.94	0.69	0.50	1.38
15NSS-FRT8-4	FRT8		(76.2)	(38.1)		(52.3)		(92.0)	(101.6)	(25.4)	(8.6)	(176.26)	(17.5)	(12.7)	(35.1)

1 on pressure															
Ordering Number	Connection	Orifice in. (mm)	Dimensions, in. (mm)												
			A	B	C	D	D1	E	F	G	G1	H	M	N	Thickness
15NSS-FNS2-5	FNS2	0.078 (1.98)	1.50	0.75	/	0.82	/	1.38	1.75	0.62	0.17	3.13	0.56	0.31	0.63
15NSS-FRT2-5	FRT2		(38.1)	(19.1)		(20.6)		(35.0)	(44.5)	(15.8)	(4.3)	(79.5)	(14.2)	(7.9)	(15.9)
15NSS-FNS4-5	FNS4	0.203 (5.2)	2.00	1.00	/	1.41	/	2.44	3.00	0.75	0.22	5.33	0.62	0.38	0.75
15NSS-FRT4-5	FRT4		(50.8)	(25.4)		(35.8)		(62.0)	(76.2)	(19.1)	(5.6)	(135.4)	(15.8)	(9.7)	(19.1)
15NSS-FNS6-5	FNS6	0.219 (5.56)	2.50	1.25	/	1.41	/	2.44	3.00	0.75	0.22	5.34	0.62	0.38	1.00
15NSS-FRT6-5	FRT6		(63.5)	(31.8)		(35.8)		(62.0)	(76.2)	(19.1)	(5.6)	(135.7)	(15.8)	(9.7)	(25.4)
15NSS-FNS8-5	FNS8	0.312 (7.92)	3.00	1.50	/	2.06	/	3.38	4.00	1.00	0.34	6.69	0.69	0.50	1.38
15NSS-FRT8-5	FRT8		(76.2)	(38.1)		(52.3)		(85.9)	(101.6)	(25.4)	(8.6)	(169.9)	(17.5)	(12.7)	(35.1)

2 stem manifold																
Ordering Number	Connection	Orifice in. (mm)	Dimensions, in. (mm)													
			A	B	C	D	D1	E	F	G	G1	H	M	N	Thickness	
15NSS-FNS2-6	FNS2	0.078 (1.98)	1.50 (38.1)	0.75 (19.1)	/	1.00 (25.6)	0.68 (17.2)	2.02 (51.2)	1.75 (44.5)	0.62 (15.8)	0.17 (4.3)	3.77 (95.8)	0.56 (14.2)	0.31 (7.9)	0.63 (15.9)	
15NSS-FRT2-6	FRT2		15NSS-FNS4-6	FNS4		0.203 (5.2)	2.00 (50.8)	1.00 (25.4)	1.69 (42.9)	1.19 (30.2)	3.38 (85.9)	3.00 (76.2)	0.75 (19.1)	0.22 (5.6)	6.27 (159.2)	0.62 (15.8)
15NSS-FRT4-6	FRT4	15NSS-FNS6-6	FNS6	0.219 (5.56)	2.50 (63.5)	1.25 (31.8)	1.69 (42.9)	1.19 (30.2)	3.38 (85.9)	3.00 (76.2)	0.75 (19.1)	0.22 (5.6)	6.22 (158.1)	0.62 (15.8)	0.38 (9.7)	1.00 (25.4)
15NSS-FNS8-6	FNS8	0.312 (7.92)	3.00 (76.2)	1.50 (38.1)	/	2.56 (65.1)	1.75 (44.5)	5.12 (130.1)	4.00 (101.6)	1.00 (25.4)	0.34 (8.6)	8.43 (214.2)	0.69 (17.5)	0.50 (12.7)	1.38 (35.1)	
15NSS-FRT8-6	FRT8		15NSS-FNS6-6	FRT6												

- NOTES: 1. G is the drill dimension of packing gland mounting hole.
 2. G1 is the dimension of bracket mounting hole.
 3. Panel mounting drill size: 0.25" all valves.
 4. H is the dimension of stem in closed position.
 5. All dimensions for reference only and subject to change. For dimensions not shown above, please contact FITOK Group or our authorized distributors.

Fittings
Tubing
Quick Couplings
Line Filters
Valves
Sour Service Products
Subsea Valves
Tools and Installation Instructions
Technical Information
Part Number Crossover Charts

20N Series: 20,000 psig (1379 bar)

Features

- ⦿ High tensile 316 Stainless Steel for valve body and S17400 Stainless Steel for lower stem
- ⦿ Metal-to-metal seating achieves ideal shutoff, longer stem/seat service lifetime for abrasive flow, excellent corrosion resistance and greater durability for repeated on/off cycles
- ⦿ Non-rotating stem and bar stock body design
- ⦿ Easy to assemble and replace packing
- ⦿ Reliable locking for packing gland
- ⦿ Options for Vee or Regulating stem tips
- ⦿ Five flow patterns available

Technical Data

Tube O.D. in.	Connection	Orifice in. (mm)	Cv	Working Pressure psig (bar)	Working Temperature Range
1/4	MF4	0.125 (3.18)	0.31	20,000 (1379)	-100°F~1200°F (-73°C~649°C)
3/8	MF6	0.204 (5.18)	0.68	20,000 (1379)	
9/16	MF9	0.312 (7.92)	1.30	20,000 (1379)	
3/4	MF12	0.438 (11.13)	2.50	20,000 (1379)	
1	MF16	0.562 (14.27)	4.40	20,000 (1379)	

NOTES: 1. Cv values shown are for 2-way straight valve pattern. For 2-way angle pattern, increase Cv value by 50% (Based on water).
 2. Packing Options
 PTFE is the standard packing material, RPTFE glass, Graphite and extended stuffing box with Graphite also available.
 Graphite packing not recommended for Hydrogen or Helium service.
 PTFE: -100°F~450°F (-73°C~232°C)
 RPTFE glass: -100°F~600°F (-73°C~316°C)
 Graphite: 0°F~800°F (-17.8°C~427°C)
 Extended stuffing box with Graphite: 0°F~1200°F (-17.8°C~649°C)

Fittings
Tubing
Quick Couplings
Line Filters
Valves
Sour Service Products
Subsea Valves
Tools and Installation Instructions
Technical Information
Part Number Crossover Charts

Flow Data at 100°F (38°C)

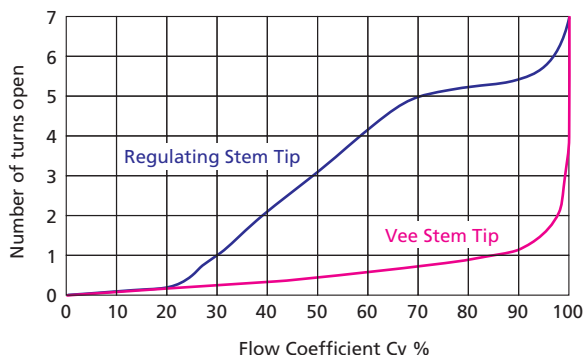

Pressure vs. Temperature Curve

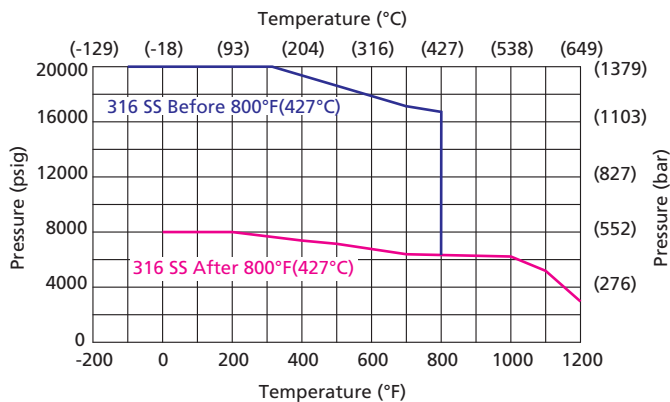

NOTE: When temperature exceeds 800°F (427°C), use the pink curve as its cold-worked rating for future operating of the components.

Standard Materials of Construction

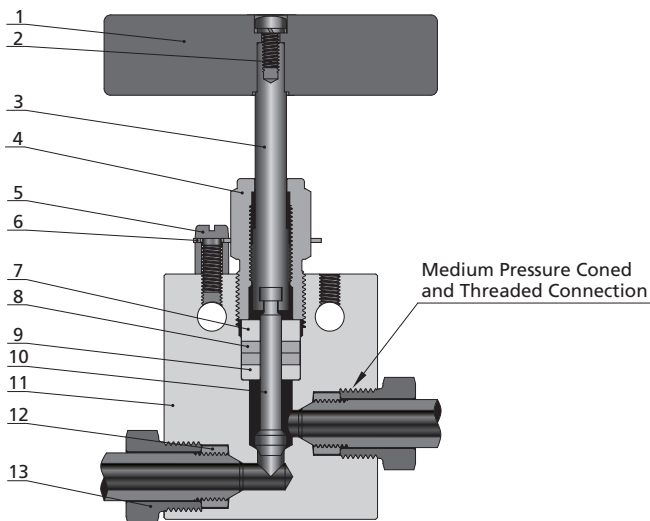

Item	Component	Material Grade
1	Handle	Stainless steel
2	Handle Screw	Stainless steel
3	Upper Stem	316 SS
4	Packing Gland	C63000
5	Locking Screw	Stainless steel
6	Locking Plate	304 SS
7	Packing Ring	C63000
8	<i>Packing</i>	<i>PTFE/RPTFE glass/Graphite/Extended stuffing box with Graphite</i>
9	<i>Packing Washer</i>	<i>S17400</i>
10	<i>Lower Stem</i>	<i>S17400</i>
11	Body	316 SS
12	Collar	316 SS (For tubing connections)
13	Gland	316 SS (For tubing connections)
	Lubricant	Molybdenum disulfide

Wetted component listed in italics.

Fittings
Tubing
Quick Couplings
Line Filters
Valves
Sour Service Products
Subsea Valves
Tools and Installation Instructions
Technical Information
Part Number Crossover Charts

Ordering Information and Dimensions (Tubing Connection, 2-Way)

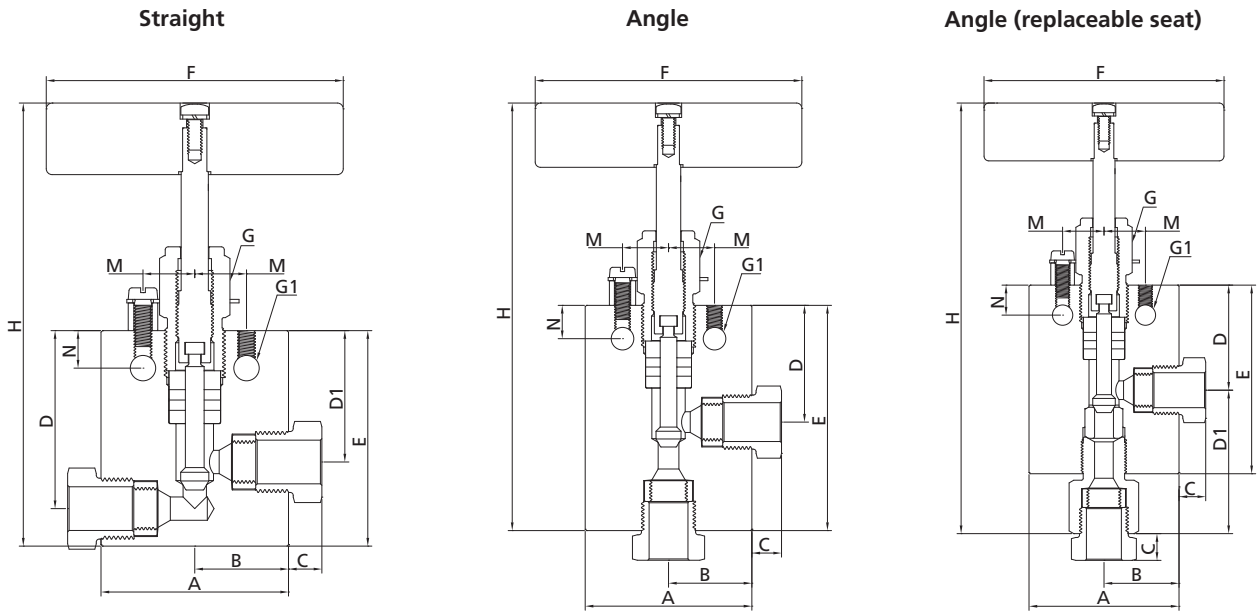

Straight															
Ordering Number	Connection	Orifice in. (mm)	Dimensions, in. (mm)												
			A	B	C	D	D1	E	F	G	G1	H	M	N	Thickness
20NSS-MF4-1	MF4	0.125 (3.18)	2.00 (50.8)	1.00 (25.4)	0.38 (9.7)	1.62 (41.2)	1.19 (30.2)	2.00 (50.8)	3.00 (76.2)	0.75 (19.1)	0.22 (5.6)	4.85 (123.1)	0.62 (15.8)	0.38 (9.7)	0.75 (19.1)
20NSS-MF6-1	MF6	0.204 (5.18)	2.00 (50.8)	1.00 (25.4)	0.44 (11.2)	1.62 (41.2)	1.19 (30.2)	2.00 (50.8)	3.00 (76.2)	0.75 (19.1)	0.22 (5.6)	4.89 (124.2)	0.62 (15.8)	0.38 (9.7)	0.75 (19.1)
20NSS-MF9-1	MF9	0.312 (7.92)	2.50 (63.5)	1.25 (31.8)	0.55 (14.0)	2.37 (60.3)	1.75 (44.5)	2.88 (73.2)	4.00 (101.6)	1.00 (25.4)	0.34 (8.6)	6.18 (157.2)	0.69 (17.5)	0.50 (12.7)	1.00 (25.4)
20NSS-MF12-1	MF12	0.438 (11.13)	3.00 (76.2)	1.50 (38.1)	0.60 (15.2)	3.00 (76.2)	2.25 (57.2)	3.75 (95.3)	10.25 (260.4)	1.19 (30.2)	0.44 (11.2)	7.37 (187.2)	0.88 (22.4)	0.63 (16.0)	1.38 (35.1)
20NSS-MF16-1	MF16	0.562 (14.27)	4.12 (104.6)	2.06 (52.3)	0.74 (18.7)	3.75 (95.3)	2.81 (71.4)	4.63 (117.6)	10.25 (260.4)	1.62 (41.2)	0.56 (14.2)	9.45 (240.1)	1.25 (31.8)	1.13 (28.7)	1.75 (44.5)

Angle															
Ordering Number	Connection	Orifice in. (mm)	Dimensions, in. (mm)												
			A	B	C	D	D1	E	F	G	G1	H	M	N	Thickness
20NSS-MF4-2	MF4	0.125 (3.18)	2.00 (50.8)	1.00 (25.4)	0.38 (9.7)	1.19 (30.2)	2.44 (61.9)	3.00 (76.2)	0.75 (19.1)	0.22 (5.6)	5.28 (134.2)	0.62 (15.8)	0.38 (9.7)	0.75 (19.1)	
20NSS-MF6-2	MF6	0.204 (5.18)	2.00 (50.8)	1.00 (25.4)	0.44 (11.2)	1.19 (30.2)	2.44 (61.9)	3.00 (76.2)	0.75 (19.1)	0.22 (5.6)	5.33 (135.4)	0.62 (15.8)	0.38 (9.7)	0.75 (19.1)	
20NSS-MF9-2	MF9	0.312 (7.92)	2.50 (63.5)	1.25 (31.8)	0.55 (14.0)	1.75 (44.5)	3.38 (85.9)	4.00 (101.6)	1.00 (25.4)	0.34 (8.6)	6.69 (170.0)	0.69 (17.5)	0.50 (12.7)	1.00 (25.4)	
20NSS-MF12-2	MF12	0.438 (11.13)	3.00 (76.2)	1.50 (38.1)	0.60 (15.2)	2.25 (57.2)	4.25 (108.0)	10.25 (260.4)	1.19 (30.2)	0.44 (11.2)	7.87 (199.9)	0.88 (22.4)	0.63 (16.0)	1.38 (35.1)	
20NSS-MF16-2	MF16	0.562 (14.27)	4.12 (104.6)	2.06 (52.3)	0.74 (18.7)	2.81 (71.4)	5.12 (130.1)	10.25 (260.4)	1.62 (41.2)	0.56 (14.2)	9.94 (252.6)	1.25 (31.8)	1.13 (28.7)	1.75 (44.5)	

Angle (replaceable seat)															
Ordering Number	Connection	Orifice in. (mm)	Dimensions, in. (mm)												
			A	B	C	D	D1	E	F	G	G1	H	M	N	Thickness
20NSS-MF4-3	MF4	0.125 (3.18)	2.00 (50.8)	1.00 (25.4)	0.38 (9.7)	1.19 (30.2)	2.13 (54.0)	2.25 (57.2)	3.00 (76.2)	0.75 (19.1)	0.22 (5.6)	6.10 (154.9)	0.62 (15.8)	0.38 (9.7)	0.75 (19.1)
20NSS-MF6-3	MF6	0.204 (5.18)	2.00 (50.8)	1.00 (25.4)	0.44 (11.2)	1.19 (30.2)	2.13 (54.0)	2.25 (57.2)	3.00 (76.2)	0.75 (19.1)	0.22 (5.6)	6.16 (156.5)	0.62 (15.8)	0.38 (9.7)	0.75 (19.1)
20NSS-MF9-3	MF9	0.312 (7.92)	2.50 (63.5)	1.25 (31.8)	0.55 (14.0)	1.75 (44.5)	2.50 (63.5)	3.13 (79.4)	4.00 (101.6)	1.00 (25.4)	0.34 (8.6)	7.58 (192.1)	0.69 (17.5)	0.50 (12.7)	1.00 (25.4)
20NSS-MF12-3	MF12	0.438 (11.13)	3.00 (76.2)	1.50 (38.1)	0.60 (15.2)	2.25 (57.2)	3.44 (87.4)	4.25 (108.0)	10.25 (260.4)	1.19 (30.2)	0.44 (11.2)	9.30 (236.3)	0.88 (22.4)	0.63 (16.0)	1.38 (35.1)
20NSS-MF16-3	MF16	0.562 (14.27)	4.12 (104.6)	2.06 (52.3)	0.74 (18.7)	2.81 (71.4)	4.22 (107.4)	5.25 (133.4)	10.25 (260.4)	1.62 (41.2)	0.56 (14.2)	11.86 (301.3)	1.25 (31.8)	1.13 (28.7)	1.75 (44.5)

Ordering Information and Dimensions (Tubing Connection, 3-Way)

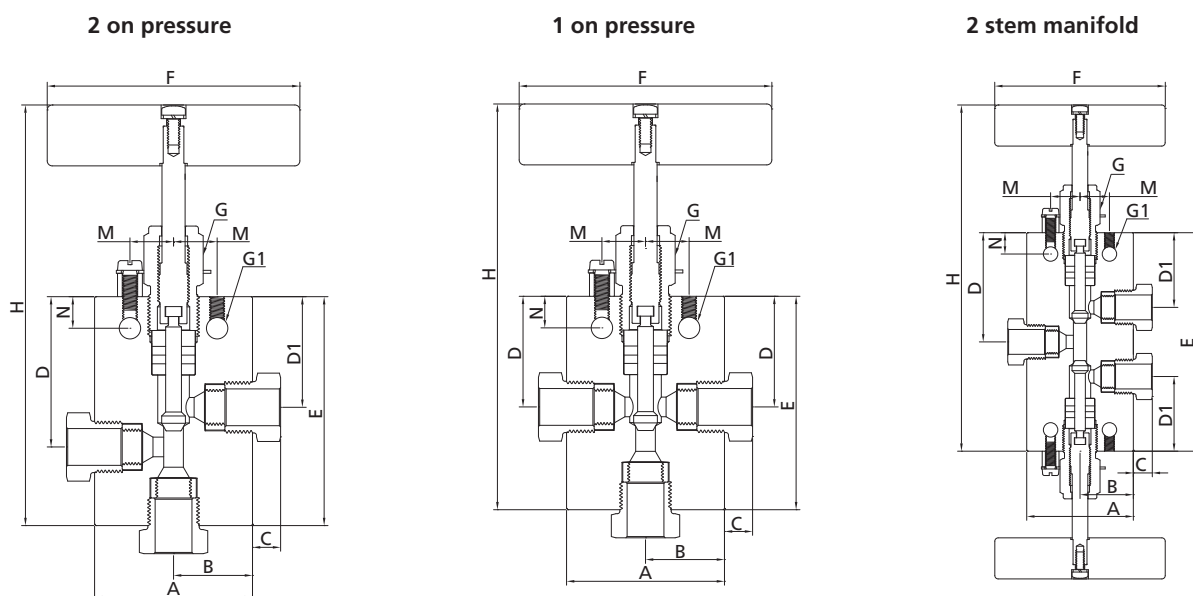

2 on pressure															
Ordering Number	Connection	Orifice in. (mm)	Dimensions, in. (mm)												
			A	B	C	D	D1	E	F	G	G1	H	M	N	Thickness
20NSS-MF4-4	MF4	0.125 (3.18)	2.00 (50.8)	1.00 (25.4)	0.38 (9.7)	1.63 (41.3)	1.19 (30.2)	2.63 (66.7)	3.00 (76.2)	0.75 (19.1)	0.22 (5.6)	5.47 (139.0)	0.62 (15.8)	0.38 (9.7)	0.75 (19.1)
20NSS-MF6-4	MF6	0.204 (5.18)	2.00 (50.8)	1.00 (25.4)	0.44 (11.2)	1.63 (41.3)	1.19 (30.2)	2.63 (66.7)	3.00 (76.2)	0.75 (19.1)	0.22 (5.6)	5.52 (140.1)	0.62 (15.8)	0.38 (9.7)	0.75 (19.1)
20NSS-MF9-4	MF9	0.312 (7.92)	2.50 (63.5)	1.25 (31.8)	0.55 (14.0)	2.37 (60.3)	1.75 (44.5)	3.63 (92.1)	4.00 (101.6)	1.00 (25.4)	0.34 (8.6)	6.94 (176.3)	0.69 (17.5)	0.50 (12.7)	1.00 (25.4)
20NSS-MF12-4	MF12	0.438 (11.13)	3.00 (76.2)	1.50 (38.1)	0.60 (15.2)	3.00 (76.2)	2.25 (57.2)	4.63 (117.5)	10.25 (260.4)	1.19 (30.2)	0.44 (11.2)	8.24 (209.4)	0.88 (22.4)	0.63 (16.0)	1.38 (35.1)
20NSS-MF16-4	MF16	0.562 (14.27)	4.12 (104.6)	2.06 (52.3)	0.74 (18.7)	3.75 (95.3)	2.81 (71.4)	5.88 (149.4)	10.25 (260.4)	1.62 (41.2)	0.56 (14.2)	10.70 (271.9)	1.25 (31.8)	1.13 (28.7)	1.75 (44.5)

E-30 Needle Valves and Pneumatic Needle Valves

1 on pressure															
Ordering Number	Connection	Orifice in. (mm)	Dimensions, in. (mm)												
			A	B	C	D	D1	E	F	G	G1	H	M	N	Thickness
20NSS-MF4-5	MF4	0.125 (3.18)	2.00 (50.8)	1.00 (25.4)	0.38 (9.7)	1.19 (30.2)		2.44 (61.9)	3.00 (76.2)	0.75 (19.1)	0.22 (5.6)	5.28 (134.2)	0.62 (15.8)	0.38 (9.7)	0.75 (19.1)
20NSS-MF6-5	MF6	0.204 (5.18)	2.00 (50.8)	1.00 (25.4)	0.44 (11.2)	1.19 (30.2)		2.44 (61.9)	3.00 (76.2)	0.75 (19.1)	0.22 (5.6)	5.33 (135.4)	0.62 (15.8)	0.38 (9.7)	0.75 (19.1)
20NSS-MF9-5	MF9	0.312 (7.92)	2.50 (63.5)	1.25 (31.8)	0.55 (14.0)	1.75 (44.5)		3.38 (85.9)	4.00 (101.6)	1.00 (25.4)	0.34 (8.6)	6.69 (170.0)	0.69 (17.5)	0.50 (12.7)	1.00 (25.4)
20NSS-MF12-5	MF12	0.438 (11.13)	3.00 (76.2)	1.50 (38.1)	0.60 (15.2)	2.25 (57.2)		4.25 (108.0)	10.25 (260.4)	1.19 (30.2)	0.44 (11.2)	7.87 (199.9)	0.88 (22.4)	0.63 (16.0)	1.38 (35.1)
20NSS-MF16-5	MF16	0.562 (14.27)	4.12 (104.6)	2.06 (52.3)	0.74 (18.7)	2.81 (71.4)		5.12 (130.1)	10.25 (260.4)	1.62 (41.2)	0.56 (14.2)	9.94 (252.6)	1.25 (31.8)	1.13 (28.7)	1.75 (44.5)

2 stem manifold															
Ordering Number	Connection	Orifice in. (mm)	Dimensions, in. (mm)												
			A	B	C	D	D1	E	F	G	G1	H	M	N	Thickness
20NSS-MF4-6	MF4	0.125 (3.18)	2.00 (50.8)	1.00 (25.4)	0.38 (9.7)	1.69 (42.9)	1.19 (30.2)	3.38 (85.7)	3.00 (76.2)	0.75 (19.1)	0.22 (5.6)	6.23 (158.1)	0.62 (15.8)	0.38 (9.7)	0.75 (19.1)
20NSS-MF6-6	MF6	0.204 (5.18)	2.00 (50.8)	1.00 (25.4)	0.44 (11.2)	1.69 (42.9)	1.19 (30.2)	3.38 (85.7)	3.00 (76.2)	0.75 (19.1)	0.22 (5.6)	6.24 (158.6)	0.62 (15.8)	0.38 (9.7)	0.75 (19.1)
20NSS-MF9-6	MF9	0.312 (7.92)	2.50 (63.5)	1.25 (31.8)	0.55 (14.0)	2.56 (65.1)	1.75 (44.5)	5.13 (130.2)	4.00 (101.6)	1.00 (25.4)	0.34 (8.6)	8.44 (214.4)	0.69 (17.5)	0.50 (12.7)	1.00 (25.4)
20NSS-MF12-6	MF12	0.438 (11.13)	3.00 (76.2)	1.50 (38.1)	0.60 (15.2)	3.00 (76.2)	2.25 (57.2)	6.50 (165.1)	10.25 (260.4)	1.19 (30.2)	0.44 (11.2)	10.11 (257.0)	0.88 (22.4)	0.63 (16.0)	1.38 (35.1)
20NSS-MF16-6	MF16	0.562 (14.27)	4.12 (104.6)	2.06 (52.3)	0.74 (18.7)	3.75 (95.3)	2.81 (71.4)	7.50 (190.5)	10.25 (260.4)	1.62 (41.2)	0.56 (14.2)	12.32 (313.0)	1.25 (31.8)	1.13 (28.7)	1.75 (44.5)

- NOTES: 1. G is the drill dimension of packing gland mounting hole.
 2. G1 is the dimension of bracket mounting hole.
 3. Panel mounting drill size: 0.25" all valves.
 4. H is the dimension of stem in closed position.
 5. All dimensions for reference only and subject to change. For dimensions not shown above, please contact FITOK Group or our authorized distributors.

Fittings
 Tubing
 Quick Couplings
 Line Filters
 Valves
 Sour Service Products
 Subsea Valves
 Tools and Installation Instructions
 Technical Information
 Part Number Crossover Charts

30N Series: 30,000 psig (2068 bar)

Features

- ⦿ High tensile 316 Stainless Steel for valve body and S17400 Stainless Steel for lower stem
- ⦿ Metal-to-metal seating achieves ideal shutoff, longer stem/seat service lifetime for abrasive flow, excellent corrosion resistance and greater durability for repeated on/off cycles
- ⦿ Non-rotating stem and bar stock body design
- ⦿ Easy to assemble and replace packing
- ⦿ Reliable packing gland locking device
- ⦿ Options for Vee or Regulating stem tips
- ⦿ Five flow patterns available

Technical Data

Tube O.D. in.	Connection	Orifice in. (mm)	Cv	Working Pressure psig (bar)	Working Temperature Range
1/4	HF4	0.094 (2.39)	0.12	30,000 (2068)	-100°F~600°F (-73°C~316°C)
3/8	HF6	0.125 (3.18)	0.23	30,000 (2068)	
9/16	HF9	0.125 (3.18)	0.33	30,000 (2068)	

NOTES: 1. Cv values shown are for 2-way straight valve pattern. For 2-way angle pattern, increase Cv value by 50% (Based on water).
 2. Packing Options
 PTFE is the standard packing material, RPTFE glass also available
 PTFE: -100°F~450°F (-73°C~232°C)
 RPTFE glass: -100°F~600°F(-73°C~316°C)

Flow Data at 100°F (38°C)

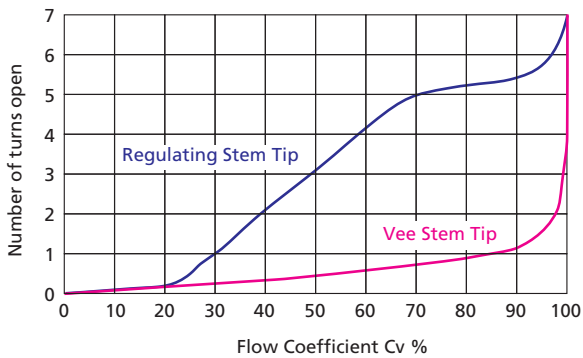

Pressure vs. Temperature Curve

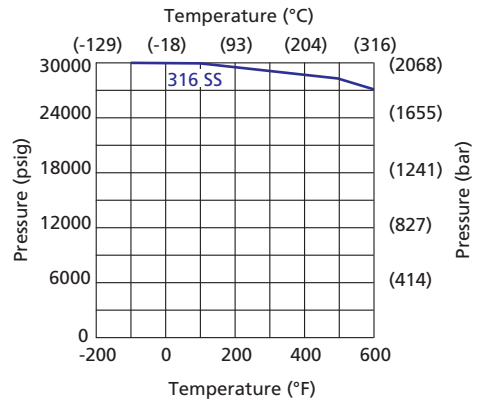

- Fittings
- Tubing
- Quick Couplings
- Line Filters
- Valves
- Sour Service Products
- Subsea Valves
- Tools and Installation Instructions
- Technical Information
- Part Number Crossover Charts

Standard Materials of Construction

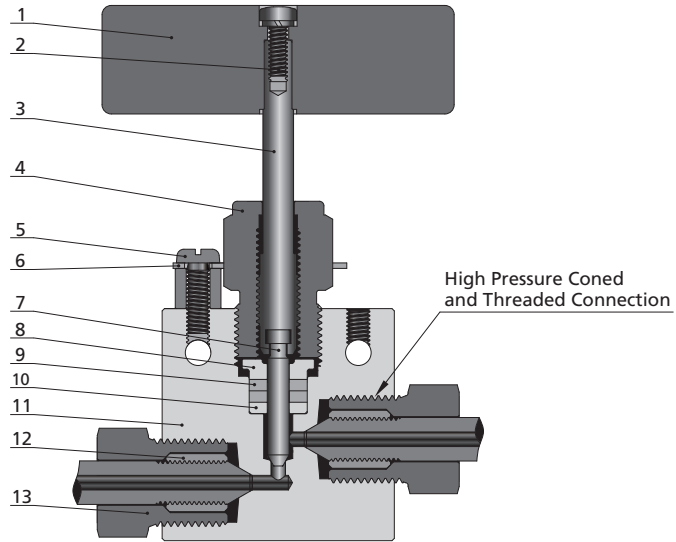

Item	Component	Material Grade
1	Handle	Stainless steel
2	Handle Screw	Stainless steel
3	Upper Stem	316 SS
4	Packing Gland	C63000
5	Locking Screw	Stainless steel
6	Locking Plate	304 SS
7	<i>Lower Stem</i>	<i>S17400</i>
8	Packing Ring	C63000
9	<i>Packing</i>	<i>PTFE / RPTFE</i>
10	<i>Packing Washer</i>	<i>S17400</i>
11	<i>Body</i>	<i>316 SS</i>
12	Collar	316 SS
13	Gland	316 SS
	Lubricant	Molybdenum disulfide

Wetted component listed in italics.

Ordering Information and Dimensions (Tubing Connection, 2-Way)

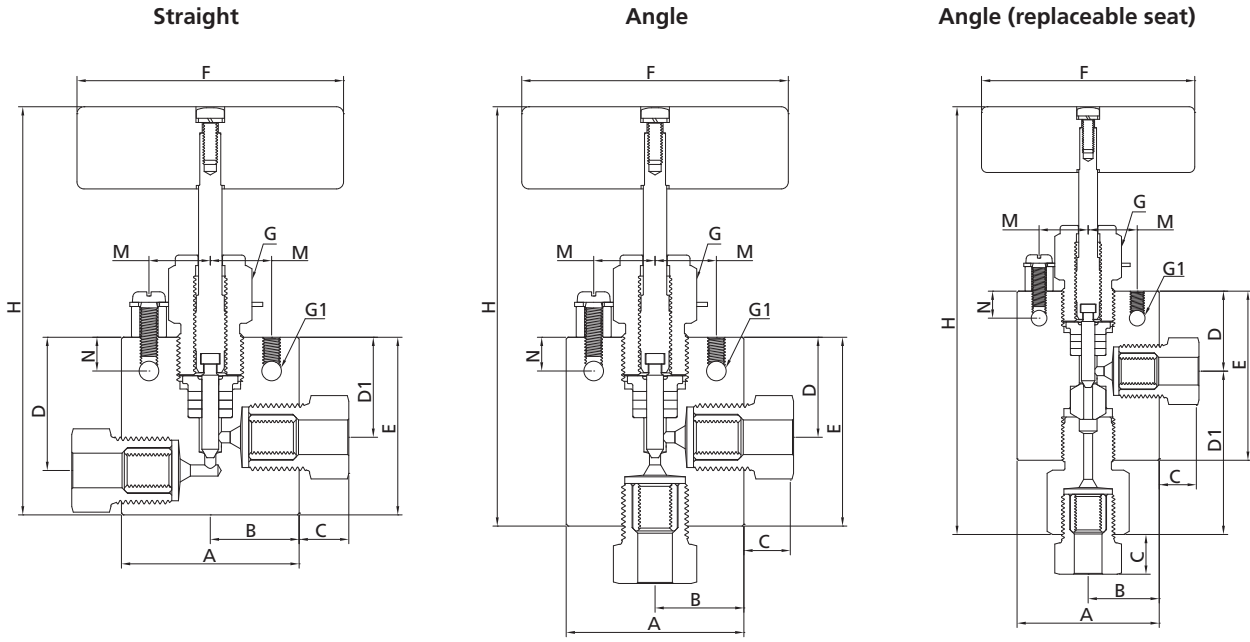

Straight															
Ordering Number	Connection	Orifice in. (mm)	Dimensions, in. (mm)												
			A	B	C	D	D1	E	F	G	G1	H	M	N	Thickness
30NSS-HF4-1	HF4	0.094 (2.39)	2.00 (50.8)	1.00 (25.4)	0.47 (11.9)	1.50 (38.1)	1.12 (28.5)	2.00 (50.8)	3.00 (76.2)	1.00 (25.4)	0.22 (5.6)	4.69 (119.1)	0.69 (17.5)	0.38 (9.7)	1.00 (25.4)
30NSS-HF6-1	HF6	0.125 (3.18)	2.00 (50.8)	1.00 (25.4)	0.61 (15.6)	1.50 (38.1)	1.12 (28.5)	2.00 (50.8)	3.00 (76.2)	1.00 (25.4)	0.22 (5.6)	4.69 (119.1)	0.69 (17.5)	0.38 (9.7)	1.00 (25.4)
30NSS-HF9-1	HF9	0.125 (3.18)	2.62 (66.6)	1.31 (33.3)	0.95 (24.1)	1.56 (39.6)	1.12 (28.5)	2.44 (62.0)	3.00 (76.2)	1.00 (25.4)	0.28 (7.1)	5.13 (130.3)	0.69 (17.5)	0.38 (9.7)	1.50 (38.1)

Angle															
Ordering Number	Connection	Orifice in. (mm)	Dimensions, in. (mm)												
			A	B	C	D	D1	E	F	G	G1	H	M	N	Thickness
30NSS-HF4-2	HF4	0.094 (2.39)	2.00 (50.8)	1.00 (25.4)	0.47 (11.9)	1.12 (28.5)	/	2.00 (50.8)	3.00 (76.2)	1.00 (25.4)	0.22 (5.6)	4.69 (119.1)	0.69 (17.5)	0.38 (9.7)	1.00 (25.4)
30NSS-HF6-2	HF6	0.125 (3.18)	2.00 (50.8)	1.00 (25.4)	0.61 (15.6)	1.12 (28.5)	/	2.25 (57.2)	3.00 (76.2)	1.00 (25.4)	0.22 (5.6)	4.95 (125.7)	0.69 (17.5)	0.38 (9.7)	1.00 (25.4)
30NSS-HF9-2	HF9	0.125 (3.18)	2.62 (66.6)	1.31 (33.3)	0.95 (24.1)	1.12 (28.5)	/	2.44 (62.0)	3.00 (76.2)	1.00 (25.4)	0.28 (7.1)	5.13 (130.3)	0.69 (17.5)	0.38 (9.7)	1.50 (38.1)

Angle (replaceable seat)															
Ordering Number	Connection	Orifice in. (mm)	Dimensions, in. (mm)												
			A	B	C	D	D1	E	F	G	G1	H	M	N	Thickness
30NSS-HF4-3	HF4	0.094 (2.39)	2.00 (50.8)	1.00 (25.4)	0.47 (11.9)	1.12 (28.5)	2.06 (52.3)	2.38 (60.5)	3.00 (76.2)	1.00 (25.4)	0.22 (5.6)	5.88 (149.2)	0.69 (17.5)	0.38 (9.7)	1.00 (25.4)
30NSS-HF6-3	HF6	0.125 (3.18)	2.00 (50.8)	1.00 (25.4)	0.61 (15.6)	1.12 (28.5)	2.31 (58.67)	2.38 (60.5)	3.00 (76.2)	1.00 (25.4)	0.22 (5.6)	6.12 (155.4)	0.69 (17.5)	0.38 (9.7)	1.00 (25.4)
30NSS-HF9-3	HF9	0.125 (3.18)	2.62 (66.6)	1.31 (33.3)	0.95 (24.1)	1.12 (28.6)	2.57 (65.3)	2.46 (62.4)	3.00 (76.2)	1.00 (25.4)	0.28 (7.1)	6.39 (162.4)	0.69 (17.5)	0.38 (9.7)	1.50 (38.1)

Fittings
Tubing
Quick Couplings
Line Filters
Valves
Sour Service Products
Subsea Valves
Tools and Installation Instructions
Technical Information
Part Number Crossover Charts

Ordering Information and Dimensions (Tubing Connection, 3-Way)

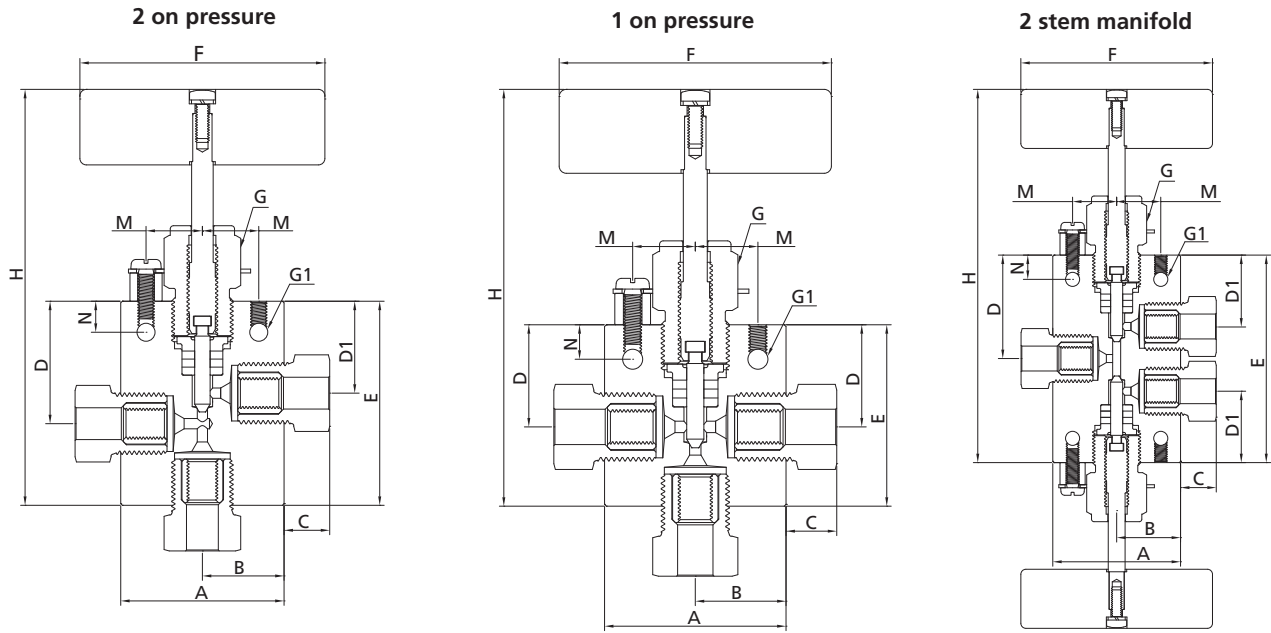

2 on pressure															
Ordering Number	Connection	Orifice in. (mm)	Dimensions, in. (mm)												
			A	B	C	D	D1	E	F	G	G1	H	M	N	Thickness
30NSS-HF4-4	HF4	0.094 (2.39)	2.00 (50.8)	1.00 (25.4)	0.47 (11.9)	1.50 (38.1)	1.12 (28.5)	2.12 (53.9)	3.00 (76.2)	1.00 (25.4)	0.22 (5.6)	4.81 (122.1)	0.69 (17.5)	0.38 (9.7)	1.00 (25.4)
30NSS-HF6-4	HF6	0.125 (3.18)	2.00 (50.8)	1.00 (25.4)	0.61 (15.6)	1.50 (38.1)	1.12 (28.5)	2.50 (63.5)	3.00 (76.2)	1.00 (25.4)	0.22 (5.6)	5.19 (131.9)	0.69 (17.5)	0.38 (9.7)	1.00 (25.4)
30NSS-HF9-4	HF9	0.125 (3.18)	2.62 (66.6)	1.31 (33.3)	0.95 (24.1)	1.56 (39.6)	1.12 (28.5)	2.88 (73.2)	3.00 (76.2)	1.00 (25.4)	0.28 (7.1)	5.57 (141.5)	0.69 (17.5)	0.38 (9.7)	1.50 (38.1)

1 on pressure															
Ordering Number	Connection	Orifice in. (mm)	Dimensions, in. (mm)												
			A	B	C	D	D1	E	F	G	G1	H	M	N	Thickness
30NSS-HF4-5	HF4	0.094 (2.39)	2.00 (50.8)	1.00 (25.4)	0.47 (11.9)	1.12 (28.5)	/	2.00 (50.8)	3.00 (76.2)	1.00 (25.4)	0.22 (5.6)	4.69 (119.1)	0.69 (17.5)	0.38 (9.7)	1.00 (25.4)
30NSS-HF6-5	HF6	0.125 (3.18)	2.00 (50.8)	1.00 (25.4)	0.61 (15.6)	1.12 (28.5)	/	2.25 (57.2)	3.00 (76.2)	1.00 (25.4)	0.22 (5.6)	4.95 (125.7)	0.69 (17.5)	0.38 (9.7)	1.00 (25.4)
30NSS-HF9-5	HF9	0.125 (3.18)	2.62 (66.6)	1.31 (33.3)	0.95 (24.1)	1.12 (28.5)	/	2.44 (62.0)	3.00 (76.2)	1.00 (25.4)	0.28 (7.1)	5.13 (130.3)	0.69 (17.5)	0.38 (9.7)	1.50 (38.1)

2 stem manifold															
Ordering Number	Connection	Orifice in. (mm)	Dimensions, in. (mm)												
			A	B	C	D	D1	E	F	G	G1	H	M	N	Thickness
30NSS-HF4-6	HF4	0.094 (2.39)	2.00 (50.8)	1.00 (25.4)	0.47 (11.9)	1.53 (38.9)	1.12 (28.5)	3.06 (77.7)	3.00 (76.2)	1.00 (25.4)	0.22 (5.6)	5.75 (146.0)	0.69 (17.5)	0.38 (9.7)	1.00 (25.4)
30NSS-HF6-6	HF6	0.125 (3.18)	2.00 (50.8)	1.00 (25.4)	0.61 (15.6)	1.62 (41.2)	1.12 (28.5)	3.25 (82.6)	3.00 (76.2)	1.00 (25.4)	0.22 (5.6)	5.94 (150.9)	0.69 (17.5)	0.38 (9.7)	1.00 (25.4)
30NSS-HF9-6	HF9	0.125 (3.18)	2.62 (66.6)	1.31 (33.3)	0.95 (24.1)	1.88 (47.8)	1.12 (28.5)	3.75 (95.3)	3.00 (76.2)	1.00 (25.4)	0.28 (7.1)	6.44 (163.6)	0.69 (17.5)	0.38 (9.7)	1.50 (38.1)

- NOTES: 1. G is the drill dimension of packing gland mounting hole.
 2. G1 is the dimension of bracket mounting hole.
 3. Panel mounting drill size: 0.25" all valves.
 4. H is the dimension of stem in closed position.
 5. All dimensions for reference only and subject to change. For dimensions not shown above, please contact FITOK Group or our authorized distributors.

60N Series: 60,000 psig (4137 bar)

Features

- ⦿ High tensile 316 Stainless Steel for valve body and S17400 Stainless Steel for lower stem
- ⦿ Metal-to-metal seating achieves ideal shutoff, longer stem/seat service lifetime for abrasive flow, excellent corrosion resistance and greater durability for repeated on/off cycles
- ⦿ Non-rotating stem and bar stock body design
- ⦿ Easy to assemble and replace packing
- ⦿ Reliable packing gland locking device
- ⦿ Options for Vee or Regulating stem tips
- ⦿ Five flow patterns available

Technical Data

Tube O.D. in.	Connection	Orifice in. (mm)	Cv	Working Pressure psig (bar)	Working Temperature Range
1/4	HF4	0.063 (1.59)	0.08	60,000 (4137)	-100°F~-600°F (-73°C~316°C)
3/8	HF6	0.063 (1.59)	0.09	60,000 (4137)	
9/16	HF9	0.078 (1.98)	0.14	60,000 (4137)	

NOTES: 1. Cv values shown are for 2-way straight valve pattern. For 2-way angle pattern, increase Cv value by 50% (Based on water).
 2. Packing Options
 Nylon is the standard packing material, RPTFE glass also available
 Nylon: 40°F~230°F (4.4°C~110°C)
 RPTFE glass: -100°F~600°F (-73°C~316°C)

Flow Data at 100°F (38°C)

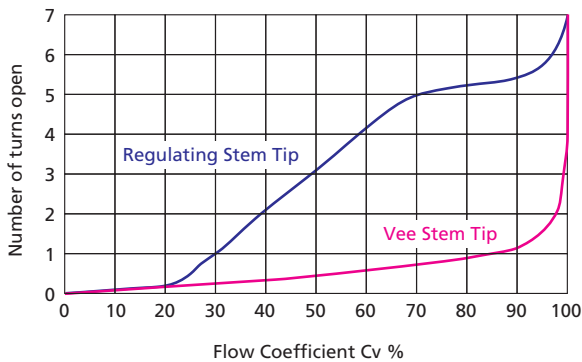

Pressure vs. Temperature Curve

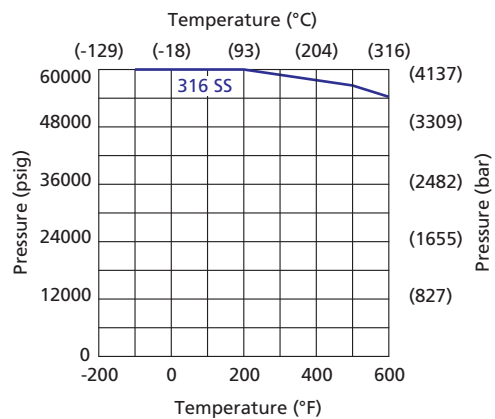

- Fittings
- Tubing
- Quick Couplings
- Line Filters
- Valves
- Sour Service Products
- Subsea Valves
- Tools and Installation Instructions
- Technical Information
- Part Number Crossover Charts

Standard Materials of Construction

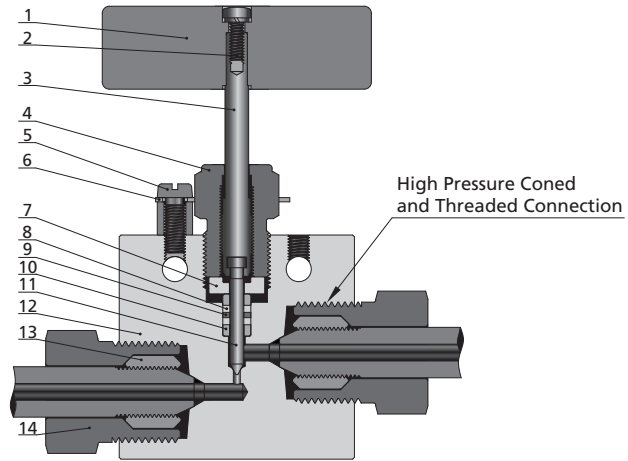

Item	Component	Material Grade
1	Handle	Stainless steel
2	Handle Screw	Stainless steel
3	Upper Stem	316 SS
4	Packing Gland	C63000
5	Locking Screw	Stainless steel
6	Locking Plate	304 SS
7	Packing Ring	<i>S17400</i>
8	<i>Packing</i>	<i>Nylon/RPTFE</i>
9	<i>Retaining Ring</i>	<i>PEEK</i>
10	<i>Packing Washer</i>	<i>S17400</i>
11	<i>Lower Stem</i>	<i>S17400</i>
12	Body	316 SS
13	Collar	316 SS
14	Gland	316 SS
	Lubricant	Molybdenum disulfide

Wetted component listed in italics.

Ordering Information and Dimensions (Tubing Connection, 2-Way)

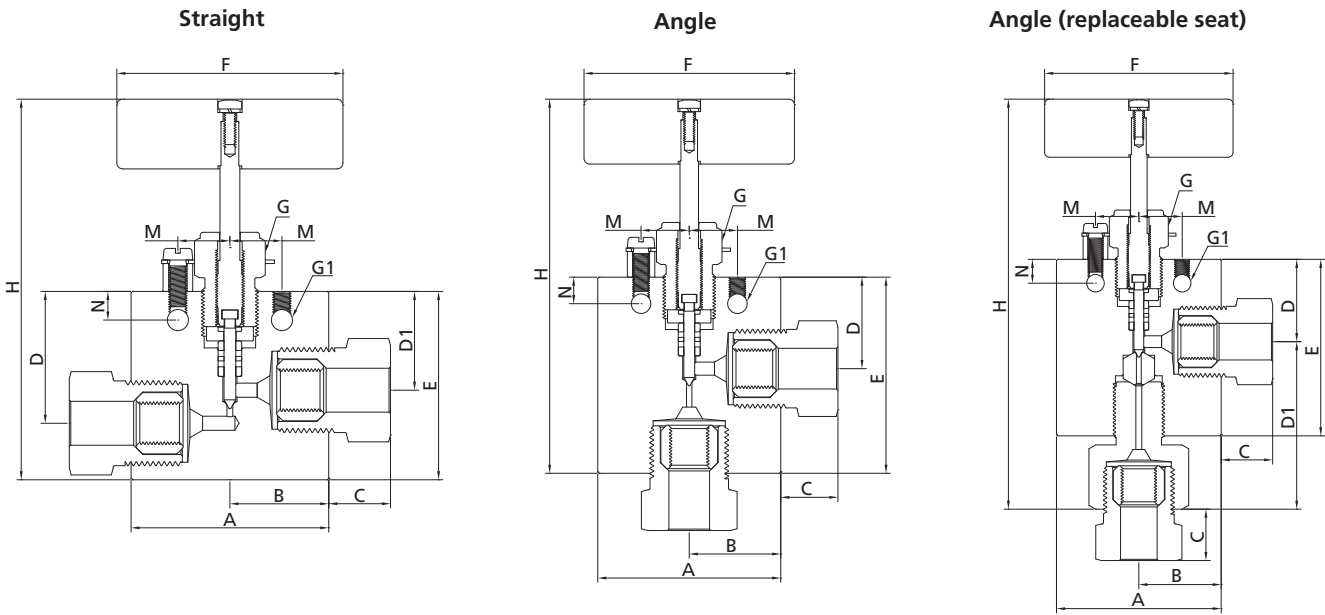

Straight

Ordering Number	Connection	Orifice in. (mm)	Dimensions, in. (mm)												
			A	B	C	D	D1	E	F	G	G1	H	M	N	Thickness
60NSS-HF4-1	HF4	0.063 (1.59)	2.00 (50.8)	1.00 (25.4)	0.47 (11.9)	1.69 (42.9)	1.31 (33.3)	2.13 (54.0)	3.00 (76.2)	1.00 (25.4)	0.22 (5.6)	4.77 (121.1)	0.69 (17.5)	0.38 (9.7)	1.00 (25.4)
60NSS-HF6-1	HF6	0.063 (1.59)	2.00 (50.8)	1.00 (25.4)	0.61 (15.6)	1.69 (42.9)	1.31 (33.3)	2.25 (57.2)	3.00 (76.2)	1.00 (25.4)	0.22 (5.6)	4.89 (124.3)	0.69 (17.5)	0.38 (9.7)	1.00 (25.4)
60NSS-HF9-1	HF9	0.078 (1.98)	2.62 (66.6)	1.31 (33.3)	0.95 (24.1)	1.75 (44.5)	1.31 (33.3)	2.50 (63.5)	3.00 (76.2)	1.00 (25.4)	0.28 (7.1)	5.14 (130.6)	0.69 (17.5)	0.38 (9.7)	1.50 (38.1)

Angle

Ordering Number	Connection	Orifice in. (mm)	Dimensions, in. (mm)												
			A	B	C	D	D1	E	F	G	G1	H	M	N	Thickness
60NSS-HF4-2	HF4	0.063 (1.59)	2.00 (50.8)	1.00 (25.4)	0.47 (11.9)	1.31 (33.3)	/	2.38 (60.5)	3.00 (76.2)	1.00 (25.4)	0.22 (5.6)	5.02 (127.5)	0.69 (17.5)	0.38 (9.7)	1.00 (25.4)
60NSS-HF6-2	HF6	0.063 (1.59)	2.00 (50.8)	1.00 (25.4)	0.61 (15.6)	1.31 (33.3)	/	2.62 (66.6)	3.00 (76.2)	1.00 (25.4)	0.22 (5.6)	5.26 (133.5)	0.69 (17.5)	0.38 (9.7)	1.00 (25.4)
60NSS-HF9-2	HF9	0.078 (1.98)	2.62 (66.6)	1.31 (33.3)	0.95 (24.1)	1.31 (33.3)	/	2.81 (71.4)	3.00 (76.2)	1.00 (25.4)	0.28 (7.1)	5.45 (138.5)	0.69 (17.5)	0.38 (9.7)	1.50 (38.1)

Angle (replaceable seat)

Ordering Number	Connection	Orifice in. (mm)	Dimensions, in. (mm)												
			A	B	C	D	D1	E	F	G	G1	H	M	N	Thickness
60NSS-HF4-3	HF4	0.063 (1.59)	2.00 (50.8)	1.00 (25.4)	0.47 (11.9)	1.31 (33.3)	2.12 (53.9)	2.62 (66.6)	3.00 (76.2)	1.00 (25.4)	0.22 (5.6)	6.07 (154.1)	0.69 (17.5)	0.38 (9.7)	1.00 (25.4)
60NSS-HF6-3	HF6	0.063 (1.59)	2.00 (50.8)	1.00 (25.4)	0.61 (15.6)	1.31 (33.3)	2.36 (59.9)	2.62 (66.6)	3.00 (76.2)	1.00 (25.4)	0.22 (5.6)	6.30 (160.1)	0.69 (17.5)	0.38 (9.7)	1.00 (25.4)
60NSS-HF9-3	HF9	0.078 (1.98)	2.62 (66.6)	1.31 (33.3)	0.95 (24.1)	1.31 (33.3)	2.68 (68.8)	2.62 (66.6)	3.00 (76.2)	1.00 (25.4)	0.28 (7.1)	6.65 (168.9)	0.69 (17.5)	0.38 (9.7)	1.50 (38.1)

Fittings
Tubing
Quick Couplings
Line Filters
Valves
Sour Service Products
Subsea Valves
Tools and Installation Instructions
Technical Information
Part Number Crossover Charts

Ordering Information and Dimensions (Tubing Connection, 3-Way)

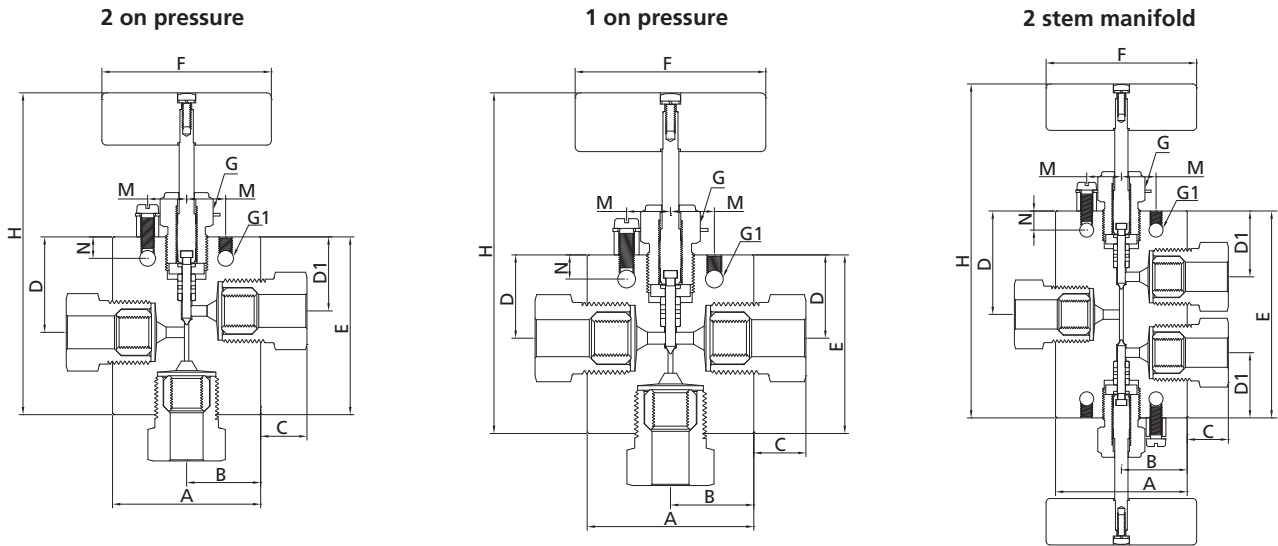

2 on pressure															
Ordering Number	Connection	Orifice in. (mm)	Dimensions, in. (mm)												
			A	B	C	D	D1	E	F	G	G1	H	M	N	Thickness
60NSS-HF4-4	HF4	0.063 (1.59)	2.00 (50.8)	1.00 (25.4)	0.47 (11.9)	1.69 (42.9)	1.31 (33.3)	2.38 (60.5)	3.00 (76.2)	1.00 (25.4)	0.22 (5.6)	5.26 (133.6)	0.69 (17.5)	0.38 (9.7)	1.00 (25.4)
60NSS-HF6-4	HF6	0.063 (1.59)	2.00 (50.8)	1.00 (25.4)	0.61 (15.6)	1.69 (42.9)	1.31 (33.3)	2.75 (68.9)	3.00 (76.2)	1.00 (25.4)	0.22 (5.6)	5.34 (135.8)	0.69 (17.5)	0.38 (9.7)	1.00 (25.4)
60NSS-HF9-4	HF9	0.078 (1.98)	2.62 (66.6)	1.31 (33.3)	0.95 (24.1)	1.75 (44.5)	1.31 (33.3)	3.03 (77.0)	3.00 (76.2)	1.00 (25.4)	0.28 (7.1)	5.67 (143.9)	0.69 (17.5)	0.38 (9.7)	1.50 (38.1)

1 on pressure															
Ordering Number	Connection	Orifice in. (mm)	Dimensions, in. (mm)												
			A	B	C	D	D1	E	F	G	G1	H	M	N	Thickness
60NSS-HF4-5	HF4	0.063 (1.59)	2.00 (50.8)	1.00 (25.4)	0.47 (11.9)	1.31 (33.3)	/	2.38 (60.5)	3.00 (76.2)	1.00 (25.4)	0.22 (5.6)	5.02 (127.5)	0.69 (17.5)	0.38 (9.7)	1.00 (25.4)
60NSS-HF6-5	HF6	0.063 (1.59)	2.00 (50.8)	1.00 (25.4)	0.61 (15.6)	1.31 (33.3)	/	2.62 (66.6)	3.00 (76.2)	1.00 (25.4)	0.22 (5.6)	5.26 (133.5)	0.69 (17.5)	0.38 (9.7)	1.00 (25.4)
60NSS-HF9-5	HF9	0.078 (1.98)	2.62 (66.6)	1.31 (33.3)	0.95 (24.1)	1.31 (33.3)	/	2.81 (71.4)	3.00 (76.2)	1.00 (25.4)	0.28 (7.1)	5.45 (138.5)	0.69 (17.5)	0.38 (9.7)	1.50 (38.1)

2 stem manifold															
Ordering Number	Connection	Orifice in. (mm)	Dimensions, in. (mm)												
			A	B	C	D	D1	E	F	G	G1	H	M	N	Thickness
60NSS-HF4-6	HF4	0.063 (1.59)	2.00 (50.8)	1.00 (25.4)	0.47 (11.9)	1.72 (43.69)	1.31 (33.3)	3.44 (87.4)	3.00 (76.2)	1.00 (25.4)	0.22 (5.6)	6.08 (154.5)	0.69 (17.5)	0.38 (9.7)	1.00 (25.4)
60NSS-HF6-6	HF6	0.063 (1.59)	2.00 (50.8)	1.00 (25.4)	0.61 (15.6)	1.88 (47.8)	1.31 (33.3)	3.75 (95.3)	3.00 (76.2)	1.00 (25.4)	0.22 (5.6)	6.39 (162.3)	0.69 (17.5)	0.38 (9.7)	1.00 (25.4)
60NSS-HF9-6	HF9	0.078 (1.98)	2.62 (66.6)	1.31 (33.3)	0.95 (24.1)	2.06 (52.3)	1.31 (33.3)	4.12 (104.6)	3.00 (76.2)	1.00 (25.4)	0.28 (7.1)	6.76 (171.8)	0.69 (17.5)	0.38 (9.7)	1.50 (38.1)

NOTES: 1. G is the drill dimension of packing gland mounting hole.
 2. G1 is the dimension of bracket mounting hole.
 3. Panel mounting drill size: 0.25" all valves.
 4. H is the dimension of stem in closed position.
 5. All dimensions for reference only and subject to change. For dimensions not shown above, please contact FITOK Group or our authorized distributors.

Fittings
 Tubing
 Quick Couplings
 Line Filters
 Valves
 Sour Service Products
 Subsea Valves
 Tools and Installation Instructions
 Technical Information
 Part Number Crossover Charts

Pneumatic Needle Valves

Piston Style Air to Open (Normally Closed)

Features

- ⦿ Air-to-open with spring return
- ⦿ Positive shut-off with metal-to-metal seating
- ⦿ Easy stem replacement
- ⦿ Standard stem position indicator
- ⦿ High actuator cycle life
- ⦿ Anodized aluminum actuator to provide good corrosion and wear resistance
- ⦿ Tested to 100,000 cycles at 100 psig (6.9 bar) with no leakage, no signs of wear or fatigue

Technical Data

Maximum working pressure for air operator		100 psig (6.9 bar)
Air operator temperature range		-10°F~200°F (-23°C~93°C)
Air operator material	Cylinder, piston, cover plates, spring housing	Anodized Aluminum
	Yoke	Stainless Steel
	O-ring	NBR
Air inlet connection		1/8" or 3/8" Female NPT

Fittings

Tubing

Quick Couplings

Line Filters

Valves

Sour Service Products

Subsea Valves

Tools and Installation Instructions

Technical Information

Part Number Crossover Charts

Dimensions

Basic Ordering Number	Air Inlet Connection	Area of Piston sq.in. (sq. cm)	A in. (mm)	B in. (mm)	
10NSS-MF9-X-C	1/8" NPT	51.20 (330.3)	16.24 (412.5)	6.54 (166.0)	
10NSS-MF12-X-C		92.58 (597.3)	20.72 (526.3)	8.58 (218.0)	
10NSS-MF16-X-C	3/8" NPT	112.55 (726.1)	24.12 (612.7)	9.57 (243.0)	
10NSS-FNS12-X-C	1/8" NPT	92.58 (597.3)	20.72 (526.3)	8.58 (218.0)	
10NSS-FRT12-X-C		92.58 (597.3)	20.72 (526.3)	8.58 (218.0)	
10NSS-FNS16-X-C	3/8" NPT	112.55 (726.1)	24.12 (612.7)	9.57 (243.0)	
10NSS-FRT16-X-C		112.55 (726.1)	24.12 (612.7)	9.57 (243.0)	
15NSS-DFF2-X-C	1/8" NPT	7.79 (50.3)	8.56 (217.3)	3.62 (92.0)	
15NSS-DFF4-X-C		19.95 (128.7)	13.08 (332.3)	5.75 (146.0)	
15NSS-DFF6-X-C		19.95 (128.7)	13.08 (332.3)	5.75 (146.0)	
15NSS-DFF8-X-C		51.20 (330.3)	16.24 (412.5)	6.54 (166.0)	
15NSS-FNS2-X-C		7.79 (50.3)	8.56 (217.3)	3.62 (92.0)	
15NSS-FRT2-X-C		7.79 (50.3)	8.56 (217.3)	3.62 (92.0)	
15NSS-FNS4-X-C		19.95 (128.7)	13.08 (332.3)	5.75 (146.0)	
15NSS-FRT4-X-C		19.95 (128.7)	13.08 (332.3)	5.75 (146.0)	
15NSS-FNS6-X-C		19.95 (128.7)	13.08 (332.3)	5.75 (146.0)	
15NSS-FRT6-X-C		19.95 (128.7)	13.08 (332.3)	5.75 (146.0)	
15NSS-FNS8-X-C	1/8" NPT	51.20 (330.3)	16.24 (412.5)	6.54 (166.0)	
15NSS-FRT8-X-C		51.20 (330.3)	16.24 (412.5)	6.54 (166.0)	
20NSS-MF4-X-C		19.95 (128.7)	13.08 (332.3)	5.75 (146.0)	
20NSS-MF6-X-C		19.95 (128.7)	13.08 (332.3)	5.75 (146.0)	
20NSS-MF9-X-C		51.20 (330.3)	16.24 (412.5)	6.54 (166.0)	
20NSS-MF12-X-C		92.58 (597.3)	20.72 (526.3)	8.58 (218.0)	
20NSS-MF16-X-C		3/8" NPT	112.55 (726.1)	24.12 (612.7)	9.57 (243.0)
30NSS-HF4-X-C		1/8" NPT	19.95 (128.7)	13.08 (332.3)	5.75 (146.0)
30NSS-HF6-X-C			19.95 (128.7)	13.08 (332.3)	5.75 (146.0)
30NSS-HF9-X-C			19.95 (128.7)	13.08 (332.3)	5.75 (146.0)
60NSS-HF4-X-C	19.95 (128.7)		13.08 (332.3)	5.75 (146.0)	
60NSS-HF6-X-C	19.95 (128.7)		13.08 (332.3)	5.75 (146.0)	
60NSS-HF9-X-C	19.95 (128.7)		13.08 (332.3)	5.75 (146.0)	

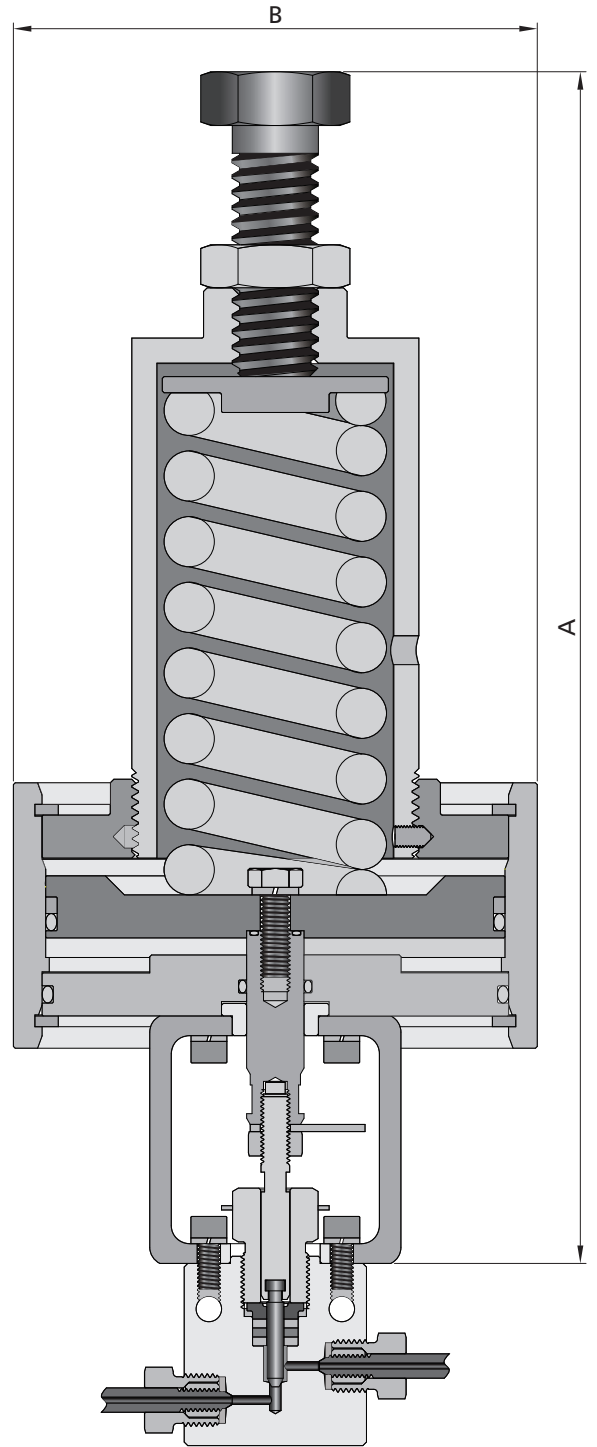

- NOTES: 1. -X: Designator of valve flow patterns. Valves are available in 5 different flow patterns (-1 to -6). For details, please refer to the FITOK Needle Valves catalog.
2. A is the dimension of stem in closed position.
3. All dimensions are for reference only and are subject to change. For dimensions not shown above, please contact FITOK Group or our authorized distributors.

Fittings
 Tubing
 Quick Couplings
 Line Filters
 Valves
 Sour Service Products
 Subsea Valves
 Tools and Installation Instructions
 Technical Information
 Part Number Crossover Charts

Air Operator Technical Data

10N Series: 10,000 psig (690 bar)

Basic Ordering Number		System Pressure KSI (MPa)				Flow Coefficient (Cv)
		1-4 (6.9-27.6)	6 (41.4)	8 (55.2)	10 (69.0)	
10NSS-MF9-X-C	Air Pressure psig (bar)	40 (2.8)	50 (3.5)	60 (4.1)	65 (4.5)	1.75
	Spring Pre-Compression in. (mm)	0.17 (4.2)	0.25 (6.3)	0.33 (8.4)	0.41 (10.5)	
	Stem Travel in. (mm)	0.26 (6.5)	0.26 (6.5)	0.26 (6.5)	0.26 (6.5)	
10NSS-MF12-X-C	Air Pressure psig (bar)	45 (3.1)	50 (3.5)	60 (4.1)	70 (4.8)	2.80
	Spring Pre-Compression in. (mm)	0.23 (5.8)	0.34 (8.7)	0.46 (11.6)	0.57 (14.5)	
	Stem Travel in. (mm)	0.36 (9.2)	0.36 (9.2)	0.36 (9.2)	0.36 (9.2)	
10NSS-MF16-X-C	Air Pressure psig (bar)	50 (3.5)	60 (4.1)	70 (4.8)	80 (5.5)	5.20
	Spring Pre-Compression in. (mm)	0.29 (7.4)	0.44 (11.1)	0.58 (14.8)	0.73 (18.5)	
	Stem Travel in. (mm)	0.41 (10.3)	0.41 (10.3)	0.41 (10.3)	0.41 (10.3)	
10NSS-FNS12-X-C 10NSS-FRT12-X-C	Air Pressure psig (bar)	40 (2.8)	45 (3.1)	50 (3.5)	60 (4.1)	2.09
	Spring Pre-Compression in. (mm)	0.17 (4.4)	0.26 (6.5)	0.34 (8.7)	0.43 (10.9)	
	Stem Travel in. (mm)	0.36 (9.2)	0.36 (9.2)	0.36 (9.2)	0.36 (9.2)	
10NSS-FNS16-X-C 10NSS-FRT16-X-C	Air Pressure psig (bar)	45 (3.1)	50 (3.5)	60 (4.1)	65 (4.5)	4.40
	Spring Pre-Compression in. (mm)	0.20 (5.1)	0.30 (7.7)	0.41 (10.3)	0.51 (12.9)	
	Stem Travel in. (mm)	0.41 (10.3)	0.41 (10.3)	0.41 (10.3)	0.41 (10.3)	

NOTES: 1. -X: Designator of valve flow patterns. Valves are available in 5 different flow patterns (-1 to -6).

For details, please refer to the FITOK Needle Valves catalog.

2. Cv values shown are for 2-way straight valve pattern. For 2-way angle pattern, increase Cv value by 50% (Based on water).

3. All dimensions are for reference only and are subject to change.

Fittings

Tubing

Quick Couplings

Line Filters

Valves

Sour Service Products

Subsea Valves

Tools and Installation Instructions

Technical Information

Part Number Crossover Charts

E-42 Needle Valves and Pneumatic Needle Valves

15N Series: 15,000 psig (1034 bar)

Fittings	Basic Ordering Number	System Pressure KSI (MPa)						Flow Coefficient (Cv)	
		1-6 (6.9-41.4)	8 (55.2)	10 (69.0)	12 (82.7)	14 (96.5)	15 (103.4)		
Tubing	15NSS-DFP2-X-C	Air Pressure psig (bar)	60 (4.1)	65 (4.5)	75 (5.2)	80 (5.5)	90 (6.2)	95 (6.6)	0.10
		Spring Pre-Compression in. (mm)	0.10 (2.5)	0.13 (3.3)	0.16 (4.1)	0.19 (4.9)	0.22 (5.7)	0.24 (6.1)	
		Stem Travel in. (mm)	0.14 (3.5)	0.14 (3.5)	0.14 (3.5)	0.14 (3.5)	0.14 (3.5)	0.14 (3.5)	
Quick Couplings	15NSS-DFP4-X-C 15NSS-DFP6-X-C	Air Pressure psig (bar)	50 (3.5)	55 (3.8)	60 (4.1)	65 (4.5)	70 (4.8)	75 (5.2)	0.54 (15NSS-DFP4-X-C) 0.95 (15NSS-DFP6-X-C)
		Spring Pre-Compression in. (mm)	0.11 (2.9)	0.15 (3.8)	0.19 (4.8)	0.23 (5.8)	0.26 (6.7)	0.28 (7.2)	
		Stem Travel in. (mm)	0.19 (4.9)	0.19 (4.9)	0.19 (4.9)	0.19 (4.9)	0.19 (4.9)	0.19 (4.9)	
Line Filters	15NSS-DFP8-X-C	Air Pressure psig (bar)	50 (3.5)	60 (4.1)	70 (4.8)	75 (5.2)	85 (5.9)	90 (6.2)	1.90
		Spring Pre-Compression in. (mm)	0.27 (6.8)	0.36 (9.1)	0.45 (11.4)	0.54 (13.6)	0.63 (15.9)	0.67 (17.0)	
		Stem Travel in. (mm)	0.26 (6.5)	0.26 (6.5)	0.26 (6.5)	0.26 (6.5)	0.26 (6.5)	0.26 (6.5)	
Valves	15NSS-FNS2-X-C 15NSS-FRT2-X-C	Air Pressure psig (bar)	60 (4.1)	65 (4.5)	75 (5.2)	80 (5.5)	90 (6.2)	95 (6.6)	0.07
		Spring Pre-Compression in. (mm)	0.10 (2.5)	0.13 (3.3)	0.16 (4.1)	0.19 (4.9)	0.22 (5.7)	0.24 (6.1)	
		Stem Travel in. (mm)	0.14 (3.5)	0.14 (3.5)	0.14 (3.5)	0.14 (3.5)	0.14 (3.5)	0.14 (3.5)	
Sour Service Products	15NSS-FNS4-X-C 15NSS-FRT4-X-C	Air Pressure psig (bar)	50 (3.5)	55 (3.8)	60 (4.1)	65 (4.5)	70 (4.8)	75 (5.2)	0.47
		Spring Pre-Compression in. (mm)	0.11 (2.9)	0.15 (3.8)	0.19 (4.8)	0.23 (5.8)	0.26 (6.7)	0.28 (7.2)	
		Stem Travel in. (mm)	0.19 (4.9)	0.19 (4.9)	0.19 (4.9)	0.19 (4.9)	0.19 (4.9)	0.19 (4.9)	
Subsea Valves	15NSS-FNS6-X-C 15NSS-FRT6-X-C	Air Pressure psig (bar)	50 (3.5)	55 (3.8)	60 (4.1)	65 (4.5)	70 (4.8)	75 (5.2)	0.59
		Spring Pre-Compression in. (mm)	0.11 (2.9)	0.15 (3.8)	0.19 (4.8)	0.23 (5.8)	0.26 (6.7)	0.28 (7.2)	
		Stem Travel in. (mm)	0.19 (4.9)	0.19 (4.9)	0.19 (4.9)	0.19 (4.9)	0.19 (4.9)	0.19 (4.9)	
Tools and Installation Instructions	15NSS-FNS8-X-C 15NSS-FRT8-X-C	Air Pressure psig (bar)	45 (3.1)	50 (3.5)	60 (4.1)	65 (4.5)	70 (4.8)	75 (5.2)	1.04
		Spring Pre-Compression in. (mm)	0.20 (5.0)	0.26 (6.6)	0.33 (8.3)	0.39 (9.9)	0.46 (11.6)	0.49 (12.4)	
		Stem Travel in. (mm)	0.26 (6.5)	0.26 (6.5)	0.26 (6.5)	0.26 (6.5)	0.26 (6.5)	0.26 (6.5)	

NOTES: 1. -X: Designator of valve flow patterns. Valves are available in 5 different flow patterns (-1 to -6). For details, please refer to the FITOK Needle Valves catalog.
 2. Cv values shown are for 2-way straight valve pattern. For 2-way angle pattern, increase Cv value by 50% (Based on water).
 3. All dimensions are for reference only and are subject to change.

Fittings
Tubing
Quick Couplings
Line Filters
Valves
Sour Service Products
Subsea Valves
Tools and Installation Instructions
Technical Information
Part Number Crossover Charts

20N Series: 20,000 psig (1379 bar)

Basic Ordering Number		System Pressure KSI (MPa)									Flow Coefficient (Cv)
		1-4 (6.9-27.6)	6 (41.4)	8 (55.2)	10 (69.0)	12 (82.7)	14 (96.5)	16 (110.3)	18 (124.1)	20 (137.9)	
20NSS-MF4-X-C 20NSS-MF6-X-C	Air Pressure psig (bar)	40 (2.8)	50 (3.5)	55 (3.8)	60 (4.1)	65 (4.5)	70 (4.8)	75 (5.2)	80 (5.5)	90 (6.2)	0.29 (20NSS-MF4-X-C)
	Spring Pre-Compression in. (mm)	0.07 (1.9)	0.11 (2.9)	0.15 (3.8)	0.19 (4.8)	0.23 (5.8)	0.26 (6.7)	0.30 (7.7)	0.34 (8.6)	0.38 (9.6)	
	Stem Travel in. (mm)	0.19 (4.9)	0.19 (4.9)	0.19 (4.9)	0.19 (4.9)	0.19 (4.9)	0.19 (4.9)	0.19 (4.9)	0.19 (4.9)	0.19 (4.9)	0.19 (4.9)
20NSS-MF9-X-C	Air Pressure psig (bar)	40 (2.8)	45 (3.1)	50 (3.5)	60 (4.1)	65 (4.5)	70 (4.8)	75 (5.2)	80 (5.5)	90 (6.2)	1.30
	Spring Pre-Compression in. (mm)	0.13 (3.3)	0.20 (5.0)	0.26 (6.6)	0.33 (8.3)	0.39 (9.9)	0.46 (11.6)	0.52 (13.2)	0.59 (14.9)	0.65 (16.5)	
	Stem Travel in. (mm)	0.26 (6.5)	0.26 (6.5)	0.26 (6.5)	0.26 (6.5)	0.26 (6.5)	0.26 (6.5)	0.26 (6.5)	0.26 (6.5)	0.26 (6.5)	
20NSS-MF12-X-C	Air Pressure psig (bar)	40 (2.8)	45 (3.1)	50 (3.5)	60 (4.1)	65 (4.5)	70 (4.8)	75 (5.2)	85 (5.9)	90 (6.2)	2.41
	Spring Pre-Compression in. (mm)	0.17 (4.4)	0.26 (6.5)	0.34 (8.7)	0.43 (10.9)	0.52 (13.1)	0.60 (15.3)	0.69 (17.4)	0.77 (19.6)	0.86 (21.8)	
	Stem Travel in. (mm)	0.36 (9.2)	0.36 (9.2)	0.36 (9.2)	0.36 (9.2)	0.36 (9.2)	0.36 (9.2)	0.36 (9.2)	0.36 (9.2)	0.36 (9.2)	
20NSS-MF16-X-C	Air Pressure psig (bar)	45 (3.1)	50 (3.5)	60 (4.1)	65 (4.5)	70 (4.8)	80 (5.5)	85 (5.9)	95 (6.6)	100 (6.9)	4.40
	Spring Pre-Compression in. (mm)	0.20 (5.1)	0.30 (7.7)	0.41 (10.3)	0.51 (12.9)	0.61 (15.4)	0.71 (18.0)	0.81 (20.6)	0.91 (23.1)	1.01 (25.7)	
	Stem Travel in. (mm)	0.41 (10.3)	0.41 (10.3)	0.41 (10.3)	0.41 (10.3)	0.41 (10.3)	0.41 (10.3)	0.41 (10.3)	0.41 (10.3)	0.41 (10.3)	

- NOTES:1. -X: Designator of valve flow patterns. Valves are available in 5 different flow patterns (-1 to -6). For details, please refer to the FITOK Needle Valves catalog.
 2. Cv values shown are for 2-way straight valve pattern. For 2-way angle pattern, increase Cv value by 50% (Based on water).
 3. All dimensions are for reference only and are subject to change.

30N Series: 30,000 psig (2068 bar)

Basic Ordering Number		System Pressure KSI (MPa)											Flow Coefficient (Cv)
		1-10 (6.9-69.0)	12 (82.7)	14 (96.5)	16 (110.3)	18 (124.1)	20 (137.9)	22 (151.7)	24 (165.5)	26 (179.3)	28 (193.1)	30 (206.8)	
30NSS-HF4-X-C 30NSS-HF6-X-C 30NSS-HF9-X-C	Air Pressure psig (bar)	55 (3.8)	60 (4.1)	65 (4.5)	65 (4.5)	70 (4.8)	75 (5.2)	80 (5.5)	85 (5.9)	90 (6.2)	95 (6.6)	100 (6.9)	0.12 (30NSS-HF4-X-C)
	Spring Pre-Compression in. (mm)	0.14 (3.8)	0.18 (4.6)	0.21 (5.4)	0.24 (6.1)	0.27 (6.9)	0.30 (7.7)	0.33 (8.4)	0.36 (9.2)	0.39 (10)	0.42 (10.7)	0.45 (11.5)	0.22 (30NSS-HF6-X-C)
	Stem Travel in. (mm)	0.19 (4.9)	0.19 (4.9)	0.19 (4.9)	0.19 (4.9)	0.19 (4.9)	0.19 (4.9)	0.19 (4.9)	0.19 (4.9)	0.19 (4.9)	0.19 (4.9)	0.19 (4.9)	0.31 (30NSS-HF9-X-C)

- NOTES: 1. -X: Designator of valve flow patterns (-1 to -6). For details, please refer to the FITOK Needle Valves catalog.
 2. Cv values shown are for 2-way straight valve pattern. For 2-way angle pattern, increase Cv value by 50% (Based on water).
 3. All dimensions are for reference only and are subject to change.

Fittings
Tubing
Quick Couplings
Line Filters
Valves
Sour Service Products
Subsea Valves
Tools and Installation Instructions
Technical Information
Part Number Crossover Charts

E-44 Needle Valves and Pneumatic Needle Valves

60N Series: 60,000 psig (4137 bar)

Basic Ordering Number		System Pressure KSI (MPa)										Flow Coefficient (Cv)
		1-15 (6.9-103.4)	20 (137.9)	25 (172.4)	30 (206.8)	35 (241.3)	40 (275.8)	45 (310.3)	50 (344.7)	55 (379.2)	60 (413.7)	
60NSS-HF4-X-C 60NSS-HF6-X-C 60NSS-HF9-X-C	Air Pressure psig (bar)	55 (3.8)	65 (4.5)	65 (4.5)	75 (5.2)	75 (5.2)	85 (5.9)	95 (6.6)	95 (6.6)	95 (6.6)	95 (6.6)	0.08 (60NSS-HF4-X-C)
	Spring Pre-Compression in. (mm)	0.12 (3.2)	0.19 (4.8)	0.19 (4.8)	0.25 (6.4)	0.25 (6.4)	0.31 (7.9)	0.38 (9.7)	0.38 (9.7)	0.44 (11.2)	0.50 (12.7)	0.09 (60NSS-HF6-X-C)
	Stem Travel in. (mm)	0.19 (4.9)	0.19 (4.9)	0.19 (4.9)	0.19 (4.9)	0.19 (4.9)	0.19 (4.9)	0.19 (4.9)	0.19 (4.9)	0.19 (4.9)	0.13 (3.2)	0.14 (60NSS-HF9-X-C)

- NOTES: 1. -X: Designator of valve flow patterns. Valves are available in 5 different flow patterns (-1 to -6). For details, please refer to the FITOK Needle Valves catalog.
2. Cv values shown are for 2-way straight valve pattern. For 2-way angle pattern, increase Cv value by 50% (Based on water).
3. All dimensions are for reference only and are subject to change.

Fittings
Tubing
Quick Couplings
Line Filters
Valves
Sour Service Products
Subsea Valves
Tools and Installation Instructions
Technical Information
Part Number Crossover Charts

Piston Style Air to Close (Normally Open)

Features

- ⦿ Air-to-close with spring return
- ⦿ Positive shut-off with metal-to-metal seating
- ⦿ Easy stem replacement
- ⦿ Standard stem position indicator
- ⦿ High actuator cycle life
- ⦿ Anodized aluminum actuator to provide good corrosion and wear resistance
- ⦿ Tested to 100,000 cycles at 100 psig (6.9 bar) with no leakage, no signs of wear or fatigue

Technical Data

Maximum working pressure for air operator		100 psig (6.9 bar)
Air operator temperature range		-10°F~200°F (-23°C~93°C)
Air operator material	Cylinder, piston, cover plates, spring housing	Anodized Aluminum
	Yoke	Stainless Steel
	O-ring	NBR
Air inlet connection		1/8" or 3/8" Female NPT

Fittings
Tubing
Quick Couplings
Line Filters
Valves
Sour Service Products
Subsea Valves
Tools and Installation Instructions
Technical Information
Part Number Crossover Charts

Dimensions

Basic Ordering Number	Air Inlet Connection	Area of Piston sq.in. (sq. cm)	A in. (mm)	B in. (mm)	
10NSS-MF9-X-O	1/8" NPT	51.20 (330.3)	8.27 (210.0)	6.54 (166.0)	
10NSS-MF12-X-O		92.58 (597.3)	10.55 (268.0)	8.58 (218.0)	
10NSS-MF16-X-O	3/8" NPT	112.55 (726.1)	12.77 (324.4)	9.57 (243.0)	
10NSS-FNS12-X-O	1/8" NPT	92.58 (597.3)	10.55 (268.0)	8.58 (218.0)	
10NSS-FRT12-X-O		92.58 (597.3)	10.55 (268.0)	8.58 (218.0)	
10NSS-FNS16-X-O	3/8" NPT	112.55 (726.1)	12.77 (324.4)	9.57 (243.0)	
10NSS-FRT16-X-O		112.55 (726.1)	12.77 (324.4)	9.57 (243.0)	
15NSS-DFF2-X-O	1/8" NPT	7.79 (50.3)	8.56 (217.3)	3.62 (92.0)	
15NSS-DFF4-X-O		19.95 (128.7)	5.94 (151.0)	5.75 (146.0)	
15NSS-DFF6-X-O		19.95 (128.7)	5.94 (151.0)	5.75 (146.0)	
15NSS-DFF8-X-O		51.20 (330.3)	8.27 (210.0)	6.54 (166.0)	
15NSS-FNS2-X-O		7.79 (50.3)	8.56 (217.3)	3.62 (92.0)	
15NSS-FRT2-X-O		7.79 (50.3)	8.56 (217.3)	3.62 (92.0)	
15NSS-FNS4-X-O		19.95 (128.7)	5.94 (151.0)	5.75 (146.0)	
15NSS-FRT4-X-O		19.95 (128.7)	5.94 (151.0)	5.75 (146.0)	
15NSS-FNS6-X-O		19.95 (128.7)	5.94 (151.0)	5.75 (146.0)	
15NSS-FRT6-X-O		19.95 (128.7)	5.94 (151.0)	5.75 (146.0)	
15NSS-FNS8-X-O	3/8" NPT	51.20 (330.3)	8.27 (210.0)	6.54 (166.0)	
15NSS-FRT8-X-O		51.20 (330.3)	8.27 (210.0)	6.54 (166.0)	
20NSS-MF4-X-O		19.95 (128.7)	5.94 (151.0)	5.75 (146.0)	
20NSS-MF6-X-O		19.95 (128.7)	5.94 (151.0)	5.75 (146.0)	
20NSS-MF9-X-O		51.20 (330.3)	8.27 (210.0)	6.54 (166.0)	
20NSS-MF12-X-O		92.58 (597.3)	10.55 (268.0)	8.58 (218.0)	
20NSS-MF16-X-O		112.55 (726.1)	12.77 (324.4)	9.57 (243.0)	
30NSS-HF4-X-O		1/8" NPT	19.95 (128.7)	5.94 (151.0)	5.75 (146.0)
30NSS-HF6-X-O			19.95 (128.7)	5.94 (151.0)	5.75 (146.0)
30NSS-HF9-X-O			19.95 (128.7)	5.94 (151.0)	5.75 (146.0)
60NSS-HF4-X-O	19.95 (128.7)		5.94 (151.0)	5.75 (146.0)	
60NSS-HF6-X-O	19.95 (128.7)		5.94 (151.0)	5.75 (146.0)	
60NSS-HF9-X-O	19.95 (128.7)		5.94 (151.0)	5.75 (146.0)	

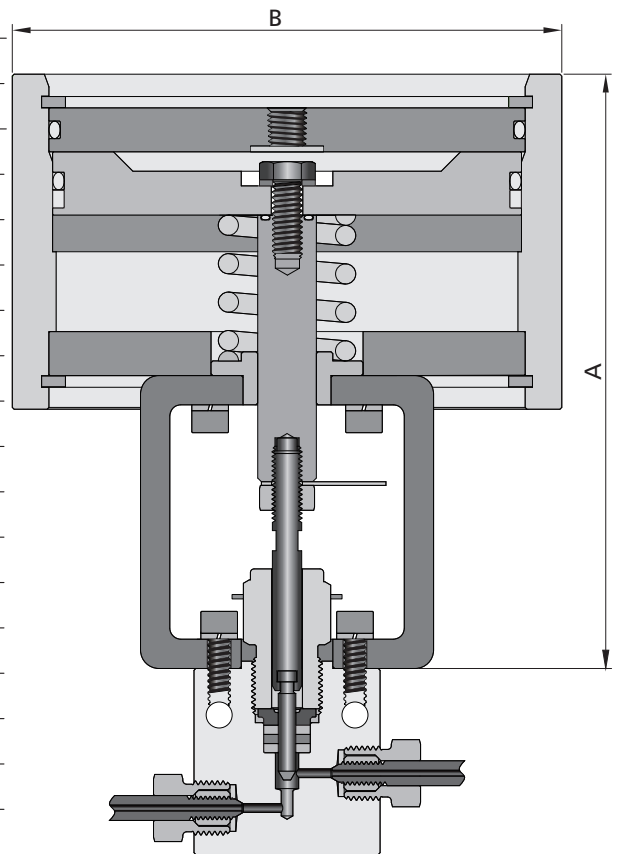

NOTES: 1. -X: Designator of valve flow patterns. Valves are available in 5 different flow patterns (-1 to -6). For details please refer to the FITOK Needle Valves catalog.
 2. All dimensions are for reference only and are subject to change. For dimensions not shown above, please contact FITOK Group or our authorized distributors.

Air Operator Technical Data

10N Series: 10,000 psig (690 bar)

Basic Ordering Number		System Pressure KSI (MPa)				Stem Travel in. (mm)	Flow Coefficient (Cv)
		1-4 (6.9-27.6)	6 (41.4)	8 (55.2)	10 (69.0)		
10NSS-MF9-X-O	Air Pressure psig (bar)	25 (1.7)	35 (2.4)	40 (2.8)	50 (3.5)	0.24 (6.0)	1.75
10NSS-MF12-X-O	Air Pressure psig (bar)	25 (1.7)	35 (2.4)	45 (3.1)	50 (3.5)	0.35 (9.0)	2.80
10NSS-MF16-X-O	Air Pressure psig (bar)	30 (2.1)	40 (2.8)	50 (3.5)	60 (4.2)	0.39 (10.0)	5.20
10NSS-FNS12-X-O 10NSS-FRT12-X-O	Air Pressure psig (bar)	25 (1.7)	30 (2.1)	35 (2.4)	40 (2.8)	0.35 (9.0)	2.09
10NSS-FNS16-X-O 10NSS-FRT16-X-O	Air Pressure psig (bar)	25 (1.7)	30 (2.1)	40 (2.8)	45 (3.1)	0.39 (10.0)	3.40

NOTES: 1. -X: Designator of valve flow patterns. Valves are available in 5 different flow patterns (-1 to -6).

For details please refer to the FITOK Needle Valves catalog.

2. Cv values shown are for 2-way straight valve pattern. For 2-way angle pattern, increase Cv value by 50% (Based on water).

3. All dimensions are for reference only and are subject to change.

15N Series: 15,000 psig (1034 bar)

Basic Ordering Number		System Pressure KSI (MPa)							Stem Travel in. (mm)	Flow Coefficient (Cv)
		1-4 (6.9-27.6)	6 (41.4)	8 (55.2)	10 (69.0)	12 (82.7)	14 (96.5)	15 (103.4)		
15NSS-DFF2-X-O	Air Pressure psig (bar)	45 (3.1)	55 (3.8)	60 (4.2)	70 (4.8)	75 (5.2)	85 (5.9)	90 (6.2)	0.12 (3.0)	0.10
15NSS-DFF4-X-O 15NSS-DFF6-X-O	Air Pressure psig (bar)	30 (2.1)	35 (2.4)	40 (2.8)	50 (3.5)	55 (3.8)	60 (4.2)	60 (4.2)	0.19 (4.9)	0.54 0.95
15NSS-DFF8-X-O	Air Pressure psig (bar)	25 (1.7)	35 (2.4)	45 (3.1)	50 (3.5)	60 (4.2)	70 (4.8)	75 (5.2)	0.24 (6.0)	1.90
15NSS-FNS2-X-O 15NSS-FRT2-X-O	Air Pressure psig (bar)	65 (4.5)	75 (5.2)	80 (5.5)	90 (6.2)	95 (6.6)	100 (6.9)	100 (6.9)	0.12 (3.0)	0.07
15NSS-FNS4-X-O 15NSS-FRT4-X-O	Air Pressure psig (bar)	30 (2.1)	35 (2.4)	40 (2.8)	50 (3.5)	55 (3.8)	60 (4.2)	60 (4.2)	0.19 (4.9)	0.47
15NSS-FNS6-X-O 15NSS-FRT6-X-O	Air Pressure psig (bar)	30 (2.1)	35 (2.4)	40 (2.8)	50 (3.5)	55 (3.8)	60 (4.2)	60 (4.2)	0.19 (4.9)	0.59
15NSS-FNS8-X-O 15NSS-FRT8-X-O	Air Pressure psig (bar)	20 (1.4)	30 (2.1)	35 (2.4)	40 (2.8)	45 (3.1)	55 (3.8)	55 (3.8)	0.24 (6.0)	1.04

NOTES: 1. -X: Designator of valve flow patterns. Valves are available in 5 different flow patterns (-1 to -6). For details, please refer to the FITOK Needle Valves catalog.

2. Cv values shown are for 2-way straight valve pattern. For 2-way angle pattern, increase Cv value by 50% (Based on water).

3. All dimensions are for reference only and are subject to change.

Fittings

Tubing

Quick Couplings

Line Filters

Valves

Sour Service Products

Subsea Valves

Tools and Installation Instructions

Technical Information

Part Number Crossover Charts

E-48 Needle Valves and Pneumatic Needle Valves

20N Series: 20,000 psig (1379 bar)

Basic Ordering Number		System Pressure KSI (MPa)									Stem Travel in. (mm)	Flow Coefficient (Cv)
		1-4 (6.9-27.6)	6 (41.4)	8 (55.2)	10 (69.0)	12 (82.7)	14 (96.5)	16 (110.3)	18 (124.1)	20 (137.9)		
20NSS-MF4-X-O	Air Pressure psig (bar)	30 (2.1)	35 (2.4)	40 (2.8)	50 (3.5)	55 (3.8)	60 (4.2)	65 (4.5)	70 (4.8)	75 (5.2)	0.19 (4.9)	0.29
20NSS-MF6-X-O		0.62										
20NSS-MF9-X-O	Air Pressure psig (bar)	20 (1.4)	30 (2.1)	35 (2.4)	40 (2.8)	45 (3.1)	55 (3.8)	60 (4.2)	65 (4.5)	70 (4.8)	0.24 (6.0)	1.30
20NSS-MF12-X-O	Air Pressure psig (bar)	25 (1.7)	30 (2.1)	35 (2.4)	40 (2.8)	45 (3.1)	55 (3.8)	60 (4.2)	65 (4.5)	70 (4.8)	0.35 (9.0)	2.41
20NSS-MF16-X-O	Air Pressure psig (bar)	25 (1.7)	30 (2.1)	40 (2.8)	45 (3.1)	55 (3.8)	60 (4.2)	65 (4.5)	75 (5.2)	80 (5.5)	0.39 (10.0)	3.40

- NOTES: 1. -X: Designator of valve flow patterns. Valves are available in 5 different flow patterns (-1 to -6). For details, please refer to the FITOK Needle Valves catalog.
 2. Cv values shown are for 2-way straight valve pattern. For 2-way angle pattern, increase Cv value by 50% (Based on water).
 3. All dimensions are for reference only and are subject to change.

30N Series: 30,000 psig (2068 bar)

Basic Ordering Number		System Pressure KSI (MPa)									Stem Travel in. (mm)	Flow Coefficient (Cv)	
		1-12 (6.9-82.7)	14 (96.5)	16 (110.3)	18 (124.1)	20 (137.9)	22 (151.7)	24 (165.7)	26 (179.3)	28 (193.1)			30 (206.8)
30NSS-HF4-X-O	Air Pressure psig (bar)	45 (3.1)	50 (3.5)	55 (3.8)	60 (4.1)	65 (4.5)	70 (4.8)	75 (5.2)	80 (5.5)	85 (5.9)	85 (5.9)	0.19 (4.9)	0.12
30NSS-HF6-X-O													0.22
30NSS-HF9-X-O													0.31

- NOTES: 1. -X: Designator of valve flow patterns. Valves are available in 5 different flow patterns (-1 to -6). For details, please refer to the FITOK Needle Valves catalog.
 2. Cv values shown are for 2-way straight valve pattern. For 2-way angle pattern, increase Cv value by 50% (Based on water).
 3. All dimensions are for reference only and are subject to change.

60N Series: 60,000 psig (4137 bar)

Basic Ordering Number		System Pressure KSI (MPa)									Stem Travel in. (mm)	Flow Coefficient (Cv)
		1-20 (6.9-137.9)	25 (172.4)	30 (206.8)	35 (241.3)	40 (275.8)	45 (310.3)	50 (344.7)	55 (379.2)	60 (413.7)		
60NSS-HF4-X-O	Air Pressure psig (bar)	35 (2.4)	40 (2.8)	50 (3.5)	55 (3.8)	65 (4.5)	70 (4.8)	75 (5.2)	85 (5.9)	90 (6.2)	0.19 (4.9)	0.08
60NSS-HF6-X-O												0.09
60NSS-HF9-X-O												0.14

- NOTES: 1. -X: Designator of valve flow patterns. Valves are available in 5 different flow patterns (-1 to -6). For details, please refer to the FITOK Needle Valves catalog.
 2. Cv values shown are for 2-way straight valve pattern. For 2-way angle pattern, increase Cv value by 50% (Based on water).
 3. All dimensions are for reference only and are subject to change.

Fittings
 Tubing
 Quick Couplings
 Line Filters
 Valves
 Sour Service Products
 Subsea Valves
 Tools and Installation Instructions
 Technical Information
 Part Number Crossover Charts

Ordering Number Description

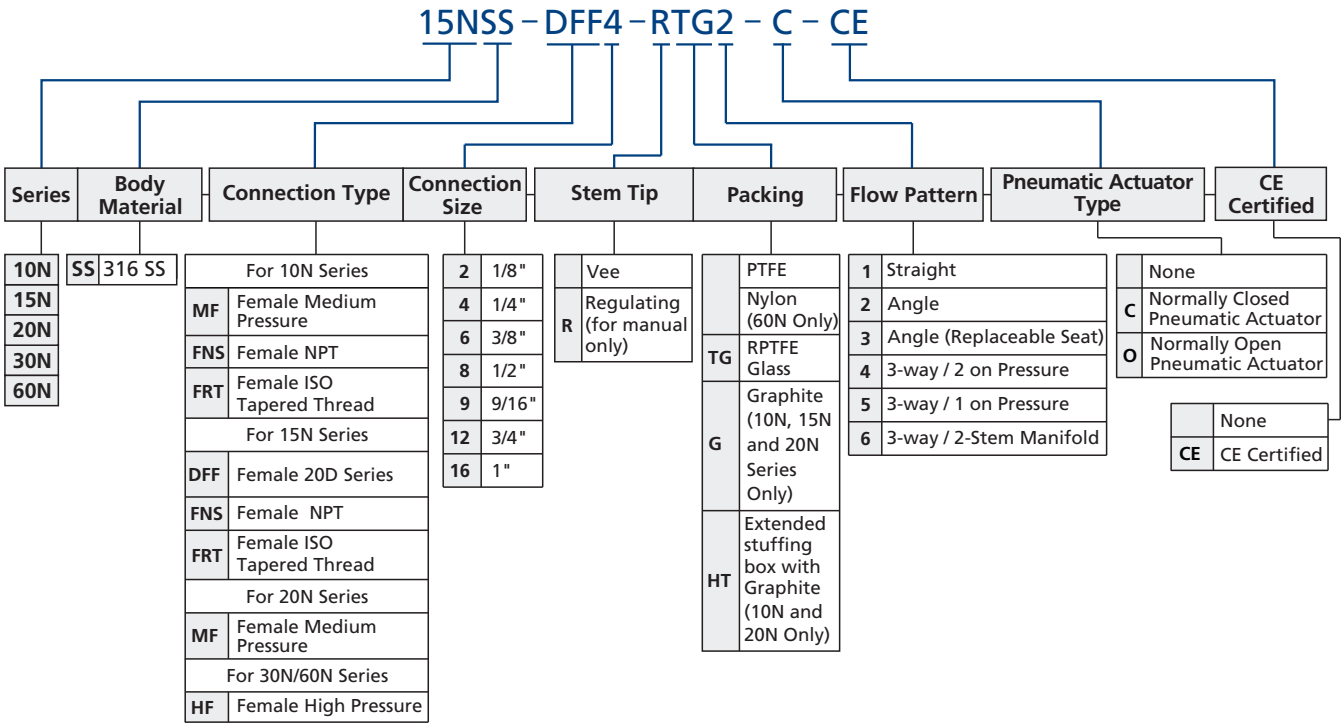

- NOTES: 1. Pneumatic needle valves are on/off valves, and will not regulate flow. It is not recommended to order pneumatic valves with regulating stems.
 2. For more details regarding 20D Series and Medium/High Pressure connections, please see **Connection Information** on I-02.
 3. "Ordering Number Description" is a reference to understand the combination rules of FITOK product part number. Not all combinations are available.

Part Number Crossover Charts
Technical Information
Tools and Installation Instructions
Subsea Valves
Sour Service Products
Valves
Line Filters
Quick Couplings
Tubing
Fittings

Stem Types

Two types of stems are offered by FITOK: Vee and Regulating. Both Vee and Regulating stems are interchangeable on most valves and provide bubble-tight shut-off against liquids and gases.

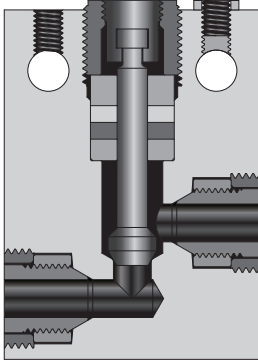

Vee Stem

The Vee stem is used for direct on-off, metal-to-metal shut-off with quick-opening flow characteristics.

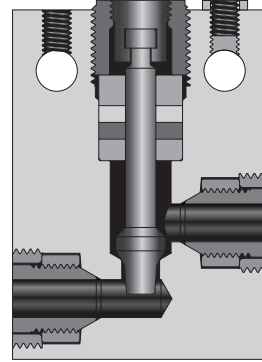

Regulating Stem

In some applications, more precise flow control is required than is possible with a Vee stem. For these cases, FITOK offers a non-rotating, two-piece regulating stem which can be used for both control and shut-off.

Fittings
Tubing
Quick Couplings
Line Filters
Valves
Sour Service Products
Subsea Valves
Tools and Installation Instructions
Technical Information
Part Number Crossover Charts