

Ball Valves

BF, BFH, BG, BH, BO, BP, BR, BRC,
BV, BK and BU Series

Ball Valves
Plug Valves

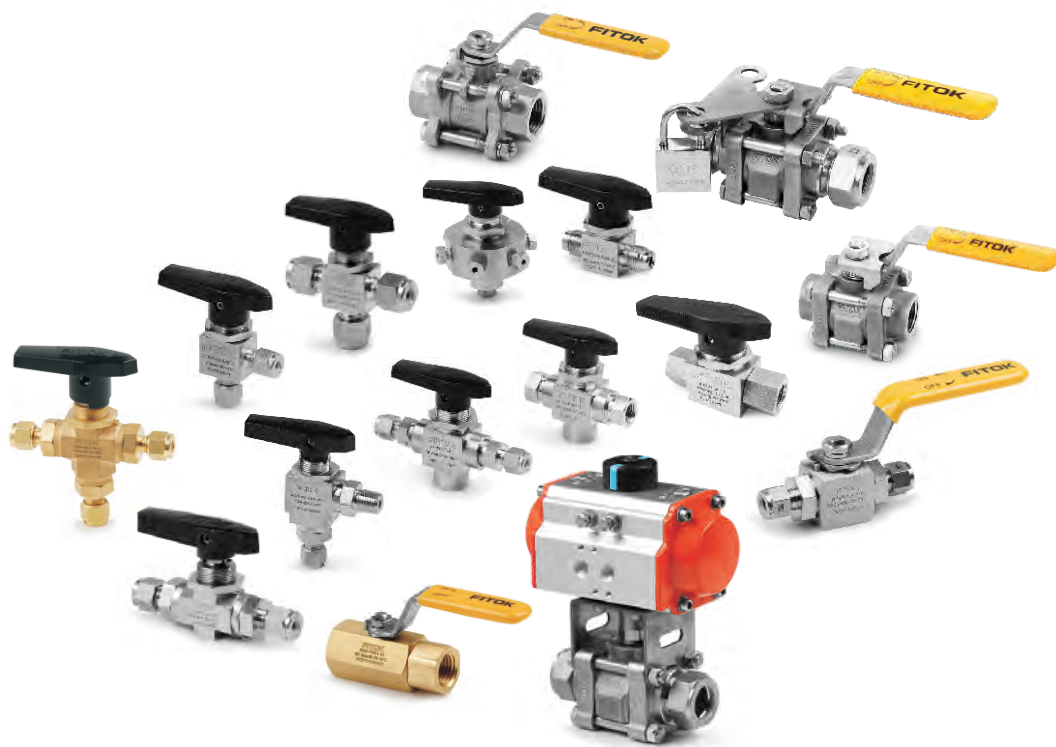

Contents

Trunnion Ball Valves

BF and BFH Series



B-04

3-piece Ball Valves

BG Series



B-11

3-piece Ball Valves

BH Series



B-16

One-piece Instrumentation Ball Valves

BO Series



B-22

Bar Stock Ball Valves

BP Series



B-36

Hex Bar Stock Ball Valves

BR and BRC Series



B-42

High Performance Ball Valves

BV Series



B-46

High Temperature Metal-seated Ball Valves

BK Series



B-55

Alternative Fuel Service (AFS) Ball Valves

BU Series



B-59

Important Information about Ball Valves

- ⦿ FITOK ball valves are designed to be used in fully open or fully closed position.
- ⦿ Packing adjustment may be required during the valve's life (except for BF, BFH and BU series).
- ⦿ For better quality maintenance, FITOK ball valves should be kept in fully open position in warehouse.
- ⦿ Valves that have not been cycled for a period of time may have a higher initial actuation torque.

Trunnion Ball Valves

BF and BFH Series

Features

- ⦿ Working pressure up to: 10,000 psig (690 bar)
- ⦿ Working temperature: 0°F to 450°F (-18°C to 232°C)
- ⦿ Orifice size: 0.19" (4.8 mm)
- ⦿ Fixed ball with double sealing
- ⦿ Trunnion-style ball to prevent ball blowout
- ⦿ Automatic compensation of seat sealing
- ⦿ Low operating torque
- ⦿ Blowout proof stem
- ⦿ Handle as indicator of flow direction
- ⦿ Positive handle stop
- ⦿ Handle color options available
- ⦿ Pneumatic and electric actuator available
- ⦿ Panel mountable
- ⦿ Leak-tight performance testing with nitrogen or compressed air for every valve at the rated pressure (not higher than 6000 psig) to meet the requirement of no visible leak
- ⦿ Compact maximum-flow design
- ⦿ 2- or 3-way flow patterns
- ⦿ Spring-load seats to provide leak tight integrity in both low-and high-pressure systems and reduce seat wear from pressure surges
- ⦿ The inlet of 3-way valve can be any port
- ⦿ Low-temperature service option available
- ⦿ BF series 3-way ball valves for "fast fill" CNG filling station application available
- ⦿ BF series ball valves with ECE R110 type approval available



Pressure vs. Temperature

BF Series

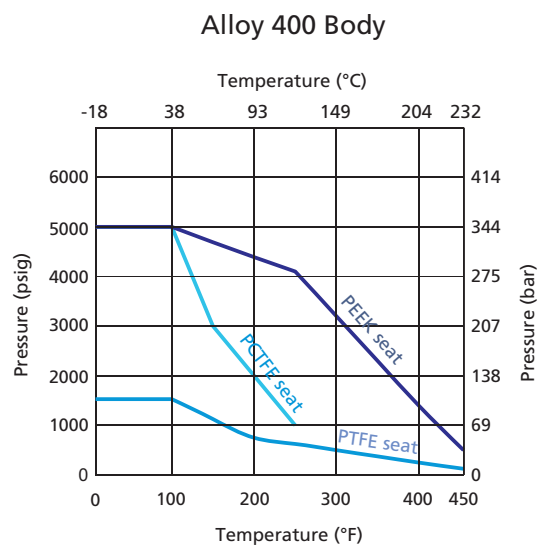
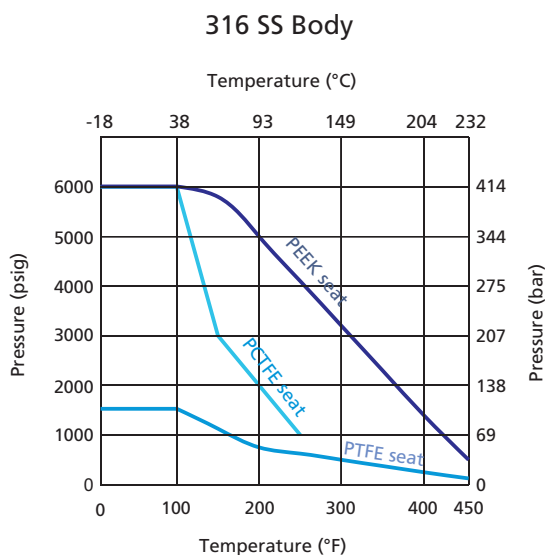

BFH Series

316 SS Body

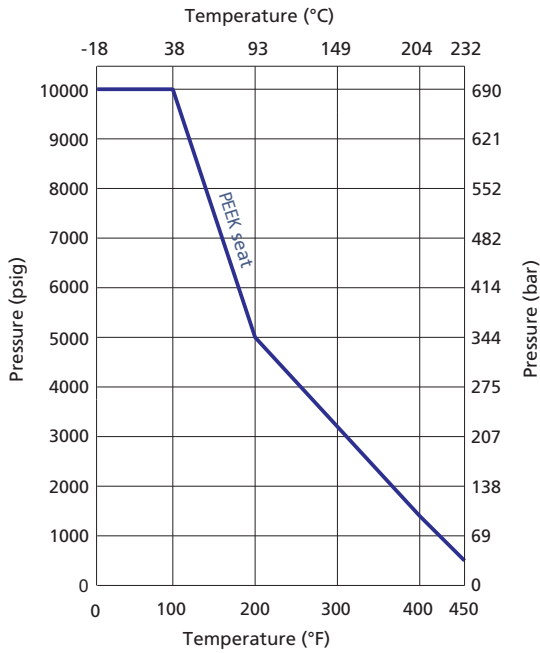

Pressure Rating@100°F (38°C)

Material	End Connection	Pressure Rating, psig (bar)
316 SS	FNS2, FNS4 FL4, ML6	10000 (690)
	ML10	8400 (578)
	FL6/ML8	7500 (516)
	FL8	6700 (461)
	ML12	6800 (470)

Note: Maximum working pressure of BFH Series ball valves is 10,000 psig. The specified pressure rating is restricted by end connections.

Ball Valves
Plug Valves

Standard Materials of Construction

BF Series

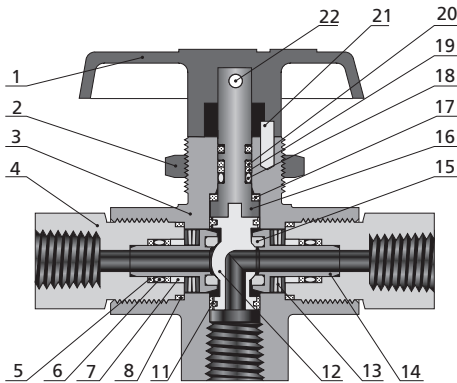
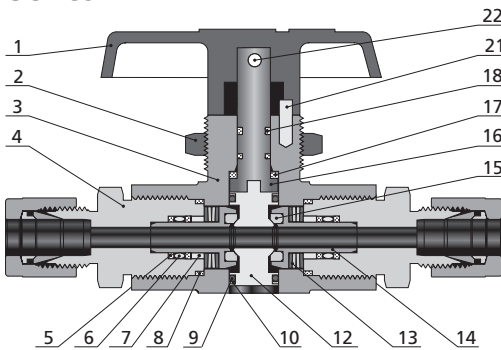

Item	Component	Valve Body Material			
		316 SS		Alloy 400	
		2-way	3-way	2-way	3-way
Material Grade/ASTM Specification					
1	Handle	Nylon with SS insert			
2	Panel Nut	316 SS/A479			
3	Body	<i>F316 SS/A182</i>		<i>Alloy 400/B164</i>	
4	End Connection	<i>316 SS/A479</i>		<i>Alloy 400/B164</i>	
5	Seat Retainer Backup Ring	<i>Reinforced PTFE</i>			
6	Seat Retainer O-ring	<i>Fluorocarbon FKM</i>			
7	Seat Retainer Guide	<i>316 SS/A479</i>		<i>Alloy 400/B164</i>	
8	End Connection Seal	<i>Silver-plated 316L/A269</i>			
9	Trunnion O-ring	<i>Fluorocarbon FKM</i>	—	<i>Fluorocarbon FKM</i>	—
10	Trunnion Backup Ring	<i>Reinforced PTFE</i>	—	<i>Reinforced PTFE</i>	—
11	Trunnion Bearing	—	<i>PEEK</i>	—	<i>PEEK</i>
12	Ball	<i>316 SS/A479</i>	<i>S21800/A479</i>	<i>Alloy 400/B164</i>	
13	Seat Spring	<i>Alloy X-750/AMS 5542</i>			
14	Seat Retainer	<i>316 SS/A479</i>		<i>Alloy 400/B164</i>	
15	Seat	<i>PTFE or PEEK or PCTFE</i>			
16	Stem	<i>316 SS/A479</i>		<i>Alloy 400/B164</i>	
17	Stem Washer	<i>PEEK</i>			
18	Stem O-ring	<i>Fluorocarbon FKM</i>	<i>Fluorocarbon FKM</i>	<i>Fluorocarbon FKM</i>	<i>Fluorocarbon FKM</i>
19	Secondary Stem Backup Ring	—	<i>PTFE/D1710</i>	—	<i>PTFE/D1710</i>
20	Primary Stem Backup Ring	—	<i>PEEK</i>	—	<i>PEEK</i>
21	Stop Pin	SS			
22	Set Screw	Galvanized carbon steel			
Lubricants		<i>Fluorinated-based</i>			

Note: Wetted components are listed in italics.

- Ball trunnions are PTFE coated for BF series 2-way valves.
- For other materials, please contact FITOK Group or our authorized distributors.

BFH Series

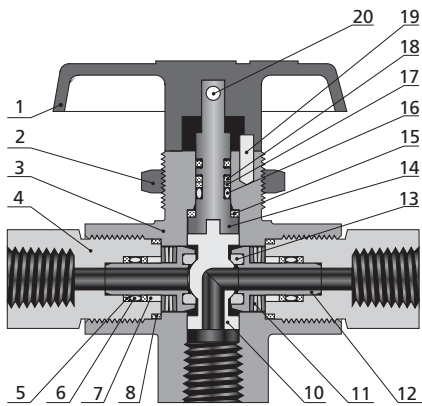
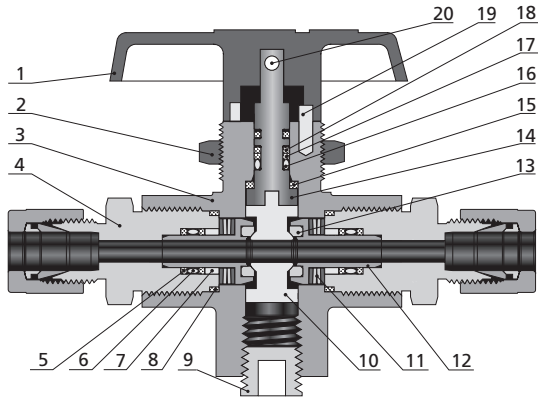

Item	Component	2-way	3-way
		Material Grade/ASTM Specification	
1	Handle	<i>Nylon with SS insert</i>	
2	Panel Nut	<i>316 SS/A479</i>	
3	Body	<i>316 SS/A182</i>	
4	End Connection	<i>316 SS/A479</i>	
5	Seat Retainer Backup Ring	<i>Reinforced PTFE</i>	
6	Seat Retainer O-ring	<i>Fluorocarbon FKM</i>	
7	Seat Retainer Guide	<i>316 SS/A479</i>	
8	End Connection Seal	<i>Silver-plated 316L/A269</i>	
9	Plug	<i>316 SS/A479</i>	
10	Ball	<i>S21800/A479</i>	
11	Seat Spring	<i>Alloy X-750/AMS 5542</i>	
12	Seat Retainer	<i>316 SS/A479</i>	
13	Seat	<i>PEEK</i>	
14	Stem	<i>316 SS/A479</i>	
15	Stem Washer	<i>PEEK</i>	
16	Stem O-ring	<i>Fluorocarbon FKM</i>	
17	Secondary Stem Backup Ring	<i>PTFE/D1710</i>	
18	Primary Stem Backup Ring	<i>PEEK</i>	
19	Stop Pin	<i>SS</i>	
20	Set Screw	<i>Galvanized carbon steel</i>	
<i>Lubricants</i>		<i>Fluorinated-based</i>	

Note: Wetted components are listed in italics.

1. Ball trunnions are PTFE coated for BFH series ball valves.

2. For other materials, please contact FITOK Group or our authorized distributors.

Dimensions

2-way Valves

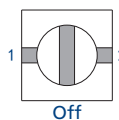
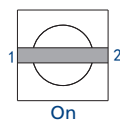
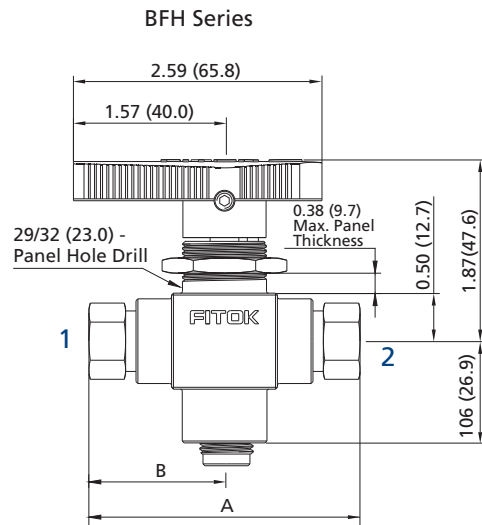
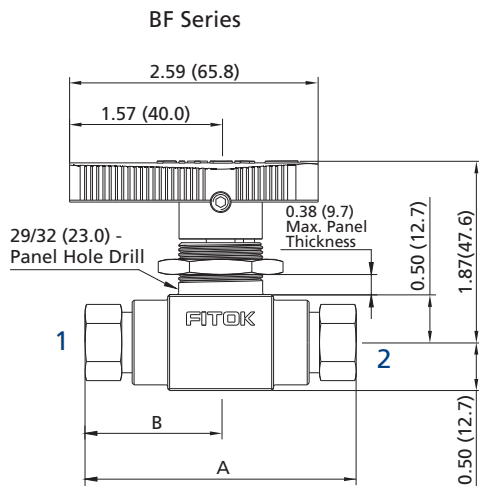

Basic Ordering Number		Connection Type and Size		Orifice in. (mm)	Cv	Dimensions, in. (mm)	
BF Series	BFH Series	Connection 1/2				A	B
BF□□-FNS2	BFH□□-FNS2-P	1/8 Female NPT		0.19 (4.8)	1.2	2.94 (74.7)	1.47 (37.3)
BF□□-FNS4	BFH□□-FNS4-P	1/4 Female NPT					
BF□□-FNS8	BFH□□-FNS4-P	1/2 Female NPT			1.0	3.93 (99.8)	1.97 (50.0)
BF□□-FL4	BFH□□-FL4-P	1/4" FITOK			1.2	4.25 (108.0)	2.13 (54.1)
BF□□-FL6	BFH□□-FL6-P	3/8" FITOK			1.6	4.14 (105.2)	2.07 (52.6)
BF□□-FL8	BFH□□-FL8-P	1/2" FITOK			1.4	4.39 (111.5)	2.19 (55.6)
BF□□-ML6	BFH□□-ML6-P	6 mm FITOK			1.0	4.60 (116.8)	2.30 (58.4)
BF□□-ML8	BFH□□-ML8-P	8 mm FITOK			1.6	4.14 (105.2)	2.07 (52.6)
BF□□-ML10	BFH□□-ML10-P	10 mm FITOK			1.5	4.15 (105.4)	2.20 (55.9)
BF□□-ML12	BFH□□-ML12-P	12 mm FITOK			1.3	4.41 (112.0)	2.20 (55.9)
					1.0	4.60 (116.8)	2.30 (58.4)

3-way Valves

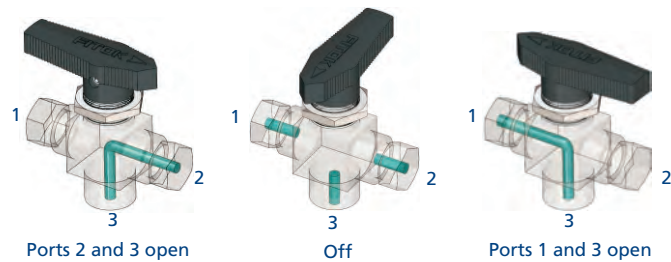
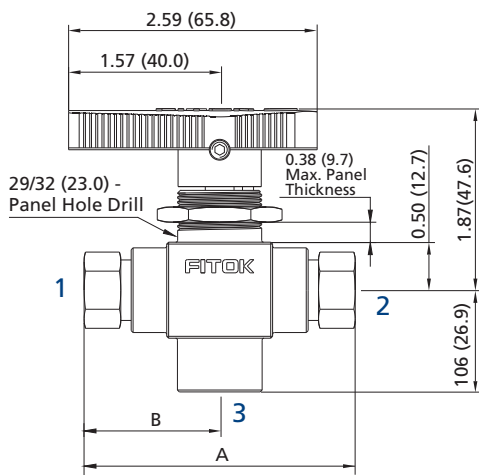

Basic Ordering Number		Connection Type and Size		Orifice in. (mm)	Cv	Dimensions, in. (mm)	
BF Series	BFH Series	Connection 1/2	Connection 3			A	B
BF□□-FNS2-3	BFH□□-FNS2-P-3	1/8 Female NPT	1/4 Female NPT	0.19 (4.8)	0.75	2.94 (74.7)	1.47 (37.3)
BF□□-FNS4-3	BFH□□-FNS4-P-3	1/4 Female NPT					
BF□□-FL4-3	BFH□□-FL4-P-3	1/4" FITOK				3.93 (99.8)	1.97 (50.0)
BF□□-FL6-3	BFH□□-FL6-P-3	3/8" FITOK				4.14 (105.2)	2.07 (52.6)
BF□□-FL8-3	BFH□□-FL8-P-3	1/2" FITOK				4.39 (111.5)	2.19 (55.6)
BF□□-ML6-3	BFH□□-ML6-P-3	6 mm FITOK				4.60 (116.8)	2.30 (58.4)
BF□□-ML8-3	BFH□□-ML8-P-3	8 mm FITOK				4.14 (105.2)	2.07 (52.6)
BF□□-ML10-3	BFH□□-ML10-P-3	10 mm FITOK				4.15 (105.4)	2.20 (55.9)
BF□□-ML12-3	BFH□□-ML12-P-3	12 mm FITOK				4.41 (112.0)	2.20 (55.9)
						4.60 (116.8)	2.30 (58.4)

1. FITOK means FITOK double ferrule tube fittings.

2. Sizes and types listed are standard. Other sizes and types are available upon request, please contact FITOK Group or our authorized distributors.

3. Dimensions are shown with tube fitting nuts finger-tightened. All dimensions are for reference only and are subject to change.

For dimensions not shown above, please contact FITOK Group or our authorized distributors.

4. Bottom port of all 3-way valves is 1/4 in. female NPT.

Special Application Ball Valves

Low-Temperature Service

BF and BFH series ball valves for low-temperature service, with a temperature rating of -40°F to 200°F (-40°C to 93°C), are available.

Low-temperature service valves have low-temperature NBR O-rings. All other materials are the same as those of standard valves. To order a valve for low-temperature service, add -LT into the valve ordering number.

For example: BFSS-FL4-P-LT

BFSS-FL4-P-3-LT

Seal kit for field replacement is available, see "Seal Kits" on Page B-09.

Low-Temperature Service BF Series Pressure vs. Temperature

316 SS Body

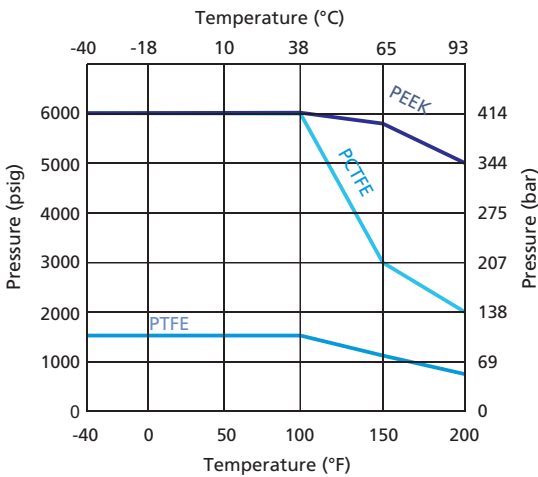

Alloy 400 Body

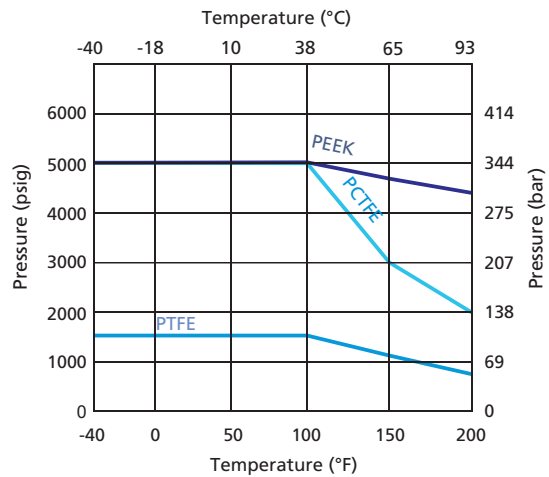

Low-Temperature Service BFH Series Pressure vs. Temperature

316 SS Body

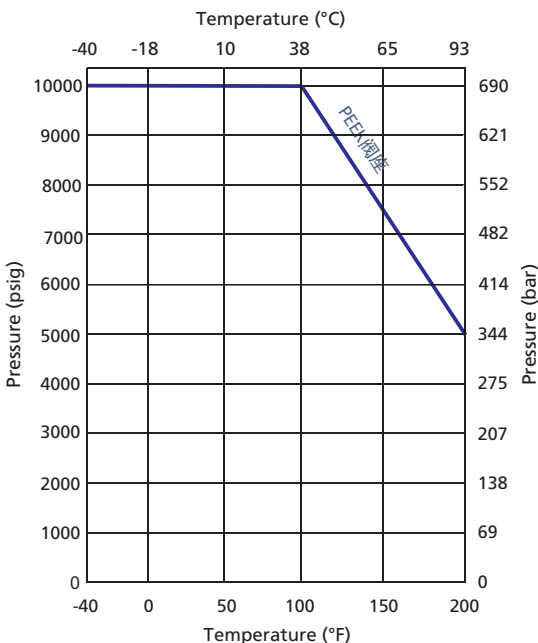

Note: The maximum working pressure for BFH series low-temperature service ball valves is the same as that of standard ball valves.

"Fast Fill" CNG Filling Station Application

BF series 3-way valves for use in "fast-fill" CNG filling station as well as a variety of filling station applications are available.

Features

- A directional installation with 90 degree actuation for ease of operation during filling
 - 3-way design with vent port for ease of venting after fill
 - PEEK seats to reduce maintenance required in high-cycle applications
 - Cycle life test report available upon request
 - Field repairable with seal kit, see "Seal Kits" on Page B-09
- To order, the flow pattern designator should be specified as "3DL" in the valve ordering number.

Example: BFSS-FNS4-P-3DL (The material and pressure vs. temperature curve are the same with those of BF series standard valves.)
 BFSS-FNS4-P-3DL-LT (The material and pressure vs. temperature curve are the same with those of BF series low-temperature service valves.)

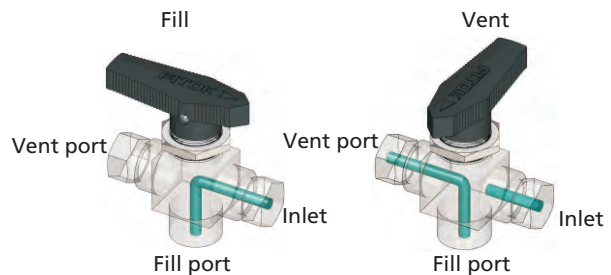

CNG/NGV Application

BF series ball valves with ECE R110 manual valve type approval available.

Classification: Class 0

Temperature rating: -40°F to 248°F (-40°C to 120°C)

Pressure rating: 3370 psig (260 bar)

CNG/NGV application valves have low-temperature FKM O-rings and PEEK seats. All other materials are the same as those of standard valves.

To order a valve for CNG/NGV application, add **-R110** into the valve ordering number.

For example: BFSS-FL4-P-**R110**

BFSS-FL4-P-3-**R110**

Seal kit for field replacement is available, see "Seal Kits" on Page B-09.

Seal Kits

Valve Series	Flow Pattern	Special Application	Basic Seal Kit Ordering Number	Content
BF	2-way	/	BFSS-2-□	Seat retainer backup ring, seat retainer O-ring, seat retainer guide, end connection seal, trunnion O-ring, trunnion backup ring, ball, seat spring, seat retainer, seat, stem, stem washer, stem O-ring, instructions.
		Low-temperature service	BFSS-2-□-LT	
		CNG/NGV application	BFSS-2-P-R110	
	3-way	/	BFSS-3-□	Seat retainer backup ring, seat retainer O-ring, seat retainer guide, end connection seal, trunnion bearing, ball, seat spring, seat retainer, seat, stem, stem washer, stem O-ring, secondary stem backup ring, primary stem backup ring, instructions.
		Low-temperature service	BFSS-3-□-LT	
		"Fast Fill" CNG filling station application	BFSS-3DL-P	
		CNG/NGV application	BFSS-3DL-P-LT	
BFH	2-way	/	BFHSS-2-P	Seat retainer backup ring, seat retainer O-ring, seat retainer guide, end connection seal, ball, seat spring, seat retainer, seat, stem, stem washer, stem O-ring, secondary stem backup ring, primary stem backup ring, instructions.
		Low-temperature service	BFHSS-2-P-LT	
	3-way	/	BFHSS-3-P	
		Low-temperature service	BFHSS-3-P-LT	

Seat Material	Designator
PTFE	T
PCTFE	K
PEEK	P

To order seal kits for BF series standard and low-temperature service ball valves, select a seat designator from the table at left and add to the basic seal kit ordering number.

Example: BFSS-2-T
BFSS-2-P-LT

Ordering numbers specify 316 stainless steel material. For other materials, replace SS in the ordering numbers with other material designators.

Example: BFM-2-T. M is the designator for Alloy 400.

Ordering Number Description

BFSS - FNS4 - ML12 - P - RXHQ3 - SCEF2

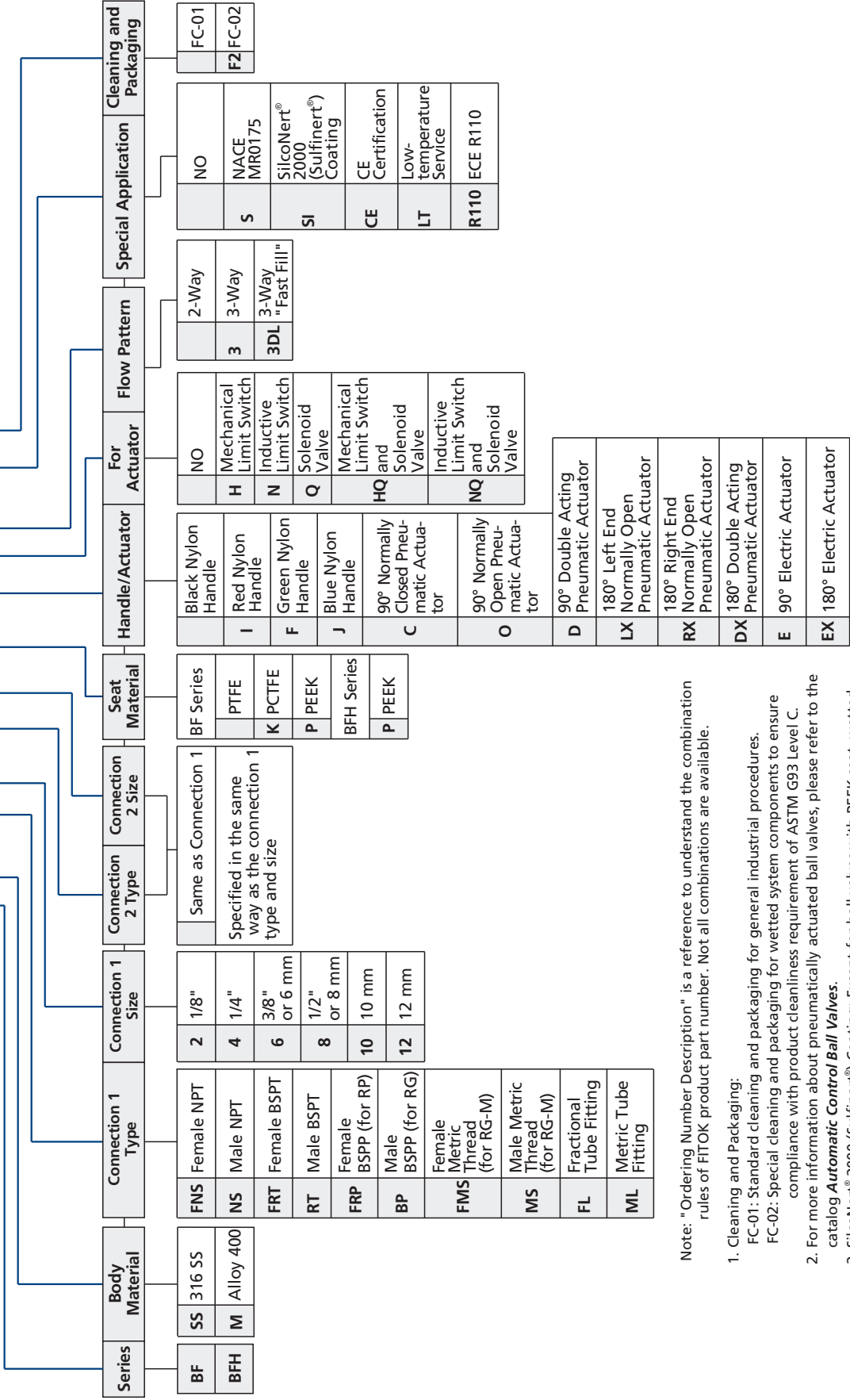

- Note: "Ordering Number Description" is a reference to understand the combination rules of FITOK product part number. Not all combinations are available.
1. Cleaning and Packaging:
 FC-01: Standard cleaning and packaging for general industrial procedures.
 FC-02: Special cleaning and packaging for wetted system components to ensure compliance with product cleanliness requirement of ASTM G93 Level C.
 2. For more information about pneumatically actuated ball valves, please refer to the catalog **Automatic Control Ball Valves**.
 3. SilcoNert® 2000 (Sulfinert®) Coating: Except for ball valves with PEEK seat, wetted metal components SilcoNert® 2000 (Sulfinert®) coated.
 4. CE certification is available. For more information, please contact FITOK group or our authorized distributors.
 5. Certifications do not include attachments to the valve, such as actuators or a different handle mechanism.

3-piece Ball Valves

BG Series

Features

- ⦿ Working pressure up to: 1000 psig (69.0 bar)
- ⦿ Working temperature: -20°F to 450°F (-28°C to 232°C)
- ⦿ End connections:
 - 1/8 to 1 thread
 - 1/8" to 1" pipe butt or socket weld
 - 1/4" to 1" and 6 mm to 25 mm tube butt or socket weld
 - 1/4" to 1" and 6 mm to 25 mm tube fitting
- ⦿ Orifice sizes: 0.19" (4.8 mm) to 1" (25 mm)
- ⦿ Blowout proof stem
- ⦿ Bidirectional flow
- ⦿ Leak-tight performance testing with nitrogen or compressed air for every valve at the rated pressure to meet the requirement of no visible leak



Pressure vs. Temperature

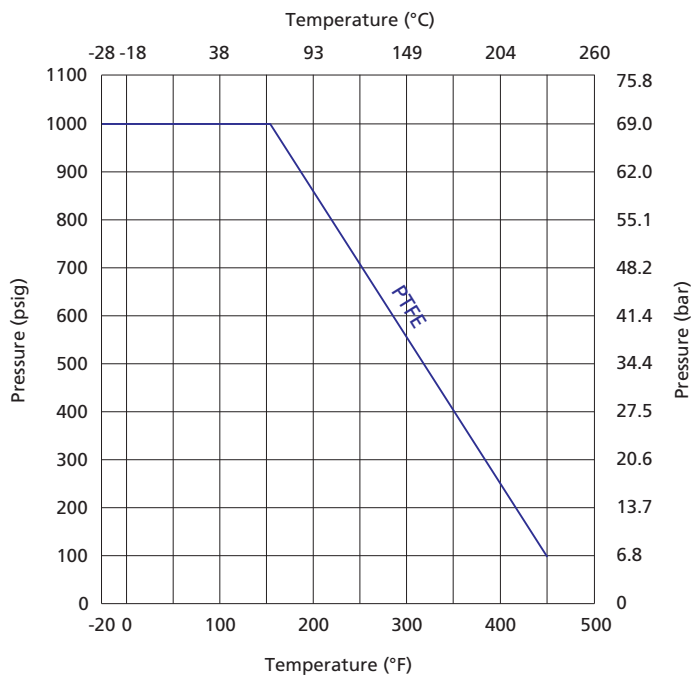

Note: The temperature and pressure rating are based on valves of standard materials.

Standard Materials of Construction

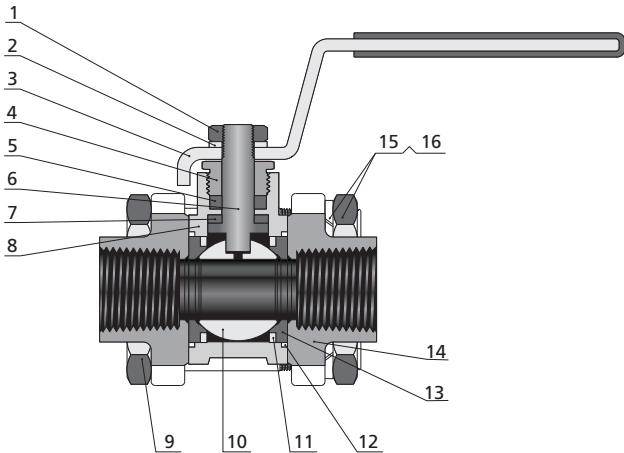

Item	Component	Valve Body Material	
		CF8M/A351	CF8/A351
1	Stem Nut	SS	
2	Gasket	SS	
3	Handle	304 SS/A240 (with vinyl sleeve)	
4	Gland	316 SS/A479 or 304 SS/A479	
5	Stem Packing	PTFE/D1710	
6	Stem	316 SS/A479 or 304 SS/A479	
7	Stem Bearing	PTFE/D1710	
8	Body	CF8M/A351	CF8/A351
9	Body Bolt	SS	
10	Ball	316 SS/A479 or 304 SS/A479	
11	Support Ring	316 SS/A240 or 304 SS/A240	
12	Flange Seal	PTFE/D1710	
13	Seat	PTFE/D1710	
14	End Connection	CF8M/A351	CF8/A351
15	Gasket	SS	
16	Nut	SS	
Lubricants		Silicone-based and PTFE-based	

Note: Wetted components are listed in italics.

For other materials, please contact FITOK Group or our authorized distributors.

Dimensions

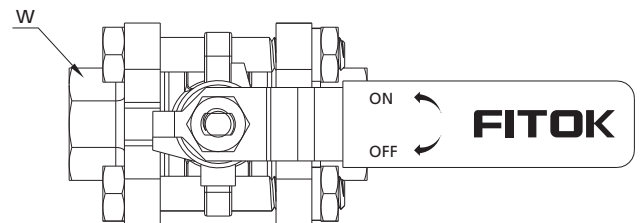
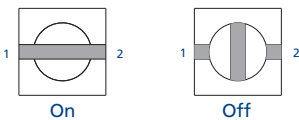
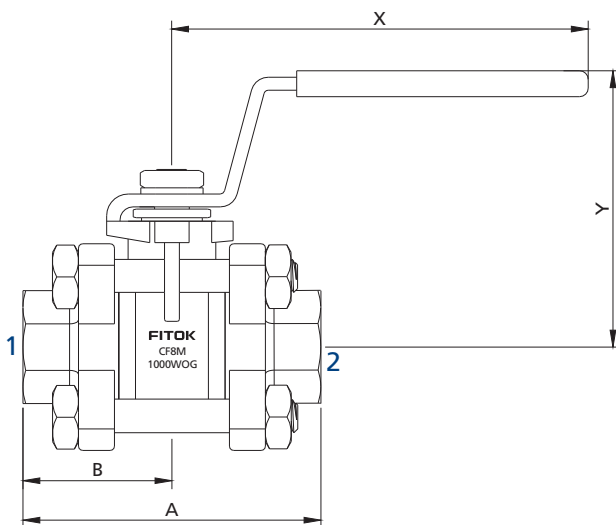

Basic Ordering Number	Connection Type and Size		Orifice in. (mm)	Cv	Dimensions, in. (mm)				
	Connection 1	Connection 2			A	B	W	X	Y
BG□□-FNS2-05	1/8 Female NPT	1/8 Female NPT	0.19 (4.8)	1.2	2.05 (52.1)	1.03 (26.0)	0.63 (16.0)	2.69 (68.3)	1.46 (37.0)
BG□□-FRP2-05	1/8 Female BSPP	1/8 Female BSPP							
BG□□-PB4-05	1/4 PB, Schedule Number: 80	1/4 PB, Schedule Number: 80							
BG□□-FL4-05	1/4" FITOK	1/4" FITOK							
BG□□-ML6-05	6 mm FITOK	6 mm FITOK							
BG□□-ML8-05	8 mm FITOK	8 mm FITOK							
BG□□-FNS4-07	1/4 Female NPT	1/4 Female NPT	0.28 (7.1)	3.8	2.05 (52.1)	1.03 (26.0)	0.93 (23.5)	3.94 (100.0)	2.19 (55.7)
BG□□-FRP4-07	1/4 Female BSPP	1/4 Female BSPP							
BG□□-FL6-07	3/8" FITOK	3/8" FITOK							
BG□□-ML10-07	10 mm FITOK	10 mm FITOK							
BG□□-FL8-11	1/2" FITOK	1/2" FITOK	0.42 (10.6)	7.5	4.04 (103.0)	2.02 (51.3)			
BG□□-ML12-11	12 mm FITOK	12 mm FITOK							
BG□□-ML14-11	14 mm FITOK	14 mm FITOK							
BG□□-FNS6-13	3/8 Female NPT	3/8 Female NPT	0.50 (12.7)	11.3	2.57 (65.2)	1.28 (32.6)	0.93 (23.5)	3.94 (100.0)	2.19 (55.7)
BG□□-FRP6-13	3/8 Female BSPP	3/8 Female BSPP							
BG□□-PS6-13	3/8 PS	3/8 PS							
BG□□-PB8-13	1/2 PB, Schedule Number: 80	1/2 PB, Schedule Number: 80							
BG□□-FL10-13	5/8" FITOK	5/8" FITOK							
BG□□-ML16-13	16 mm FITOK	16 mm FITOK							
BG□□-FNS8-15	1/2 Female NPT	1/2 Female NPT	0.55 (14.0)	13.0	2.74 (69.5)	1.37 (34.8)	1.06 (27.0)	3.94 (100.0)	2.26 (57.5)
BG□□-FRP8-15	1/2 Female BSPP	1/2 Female BSPP							
BG□□-PS8-15	1/2 PS	1/2 PS							
BG□□-MTB22-15	22 mm MTB, tube wall thickness: 3 mm	22 mm MTB, tube wall thickness: 3 mm							
BG□□-TS12-15	3/4" TS	3/4" TS							
BG□□-MTS18-15	18 mm MTS	18 mm MTS							
BG□□-FL12-15	3/4" FITOK	3/4" FITOK							
BG□□-ML18-15	18 mm FITOK	18 mm FITOK							
BG□□-FNS12-20	3/4 Female NPT	3/4 Female NPT	0.79 (20.0)	50.0	3.15 (80.0)	1.57 (40.0)	1.34 (34.0)	5.18 (131.5)	2.66 (67.5)
BG□□-FRP12-20	3/4 Female BSPP	3/4 Female BSPP							

B-14 Ball Valves

Basic Ordering Number	Connection Type and Size		Orifice in. (mm)	Cv	Dimensions, in. (mm)				
	Connection 1	Connection 2			A	B	W	X	Y
BG□□-PB12-20	3/4 PB Schedule Number: 80	3/4 PB Schedule Number: 80	0.79 (20.0)	50.0	3.15 (80.0)	1.57 (40.0)	1.34 (34.0)	5.18 (131.5)	2.66 (67.5)
BG□□-PS12-20	3/4 PS	3/4 PS							
BG□□-TS16-20	1" TS	1" TS							
BG□□-MTB25-20	25 mm MTB, tube wall thickness: 3.5 mm	25 mm MTB, tube wall thickness: 3.5 mm							
BG□□-MTS25-20	25 mm MTS	25 mm MTS			5.12 (130.0)	2.56 (65.0)	1.34 (34.0)	5.18 (131.5)	2.66 (67.5)
BG□□-FL16-20	1" FITOK	1" FITOK							
BG□□-ML22-20	22 mm FITOK	22 mm FITOK							
BG□□-ML25-20	25 mm FITOK	25 mm FITOK							
BG□□-FNS16-25	1 Female NPT	1 Female NPT	0.98 (25.0)	93.0	3.54 (90.0)	1.77 (45.0)	1.57 (40.0)	5.95 (151.2)	3.08 (78.2)
BG□□-FRP16-25	1 Female BSPP	1 Female BSPP							
BG□□-PS16-25	1 PS	1 PS							
BG□□-PB16-25	1 PB Schedule Number: 80	1 PB Schedule Number: 80							

1. FITOK means FITOK double ferrule tube fittings, TS means fractional tube socket weld, MTS means metric tube socket weld, TB means fractional tube butt weld, MTB means metric tube butt weld, PS means pipe socket weld, and PB means pipe butt weld.
2. Sizes and types listed are standard. Other sizes and types are available upon request, please contact FITOK Group or our authorized distributors.
3. Dimensions are shown with tube fitting nuts finger-tightened. All dimensions are for reference only and are subject to change. For dimensions not shown above, please contact FITOK Group or our authorized distributors.

Ordering Number Description

BGSS - FNS8 - ML18 - 15 - L - SF2

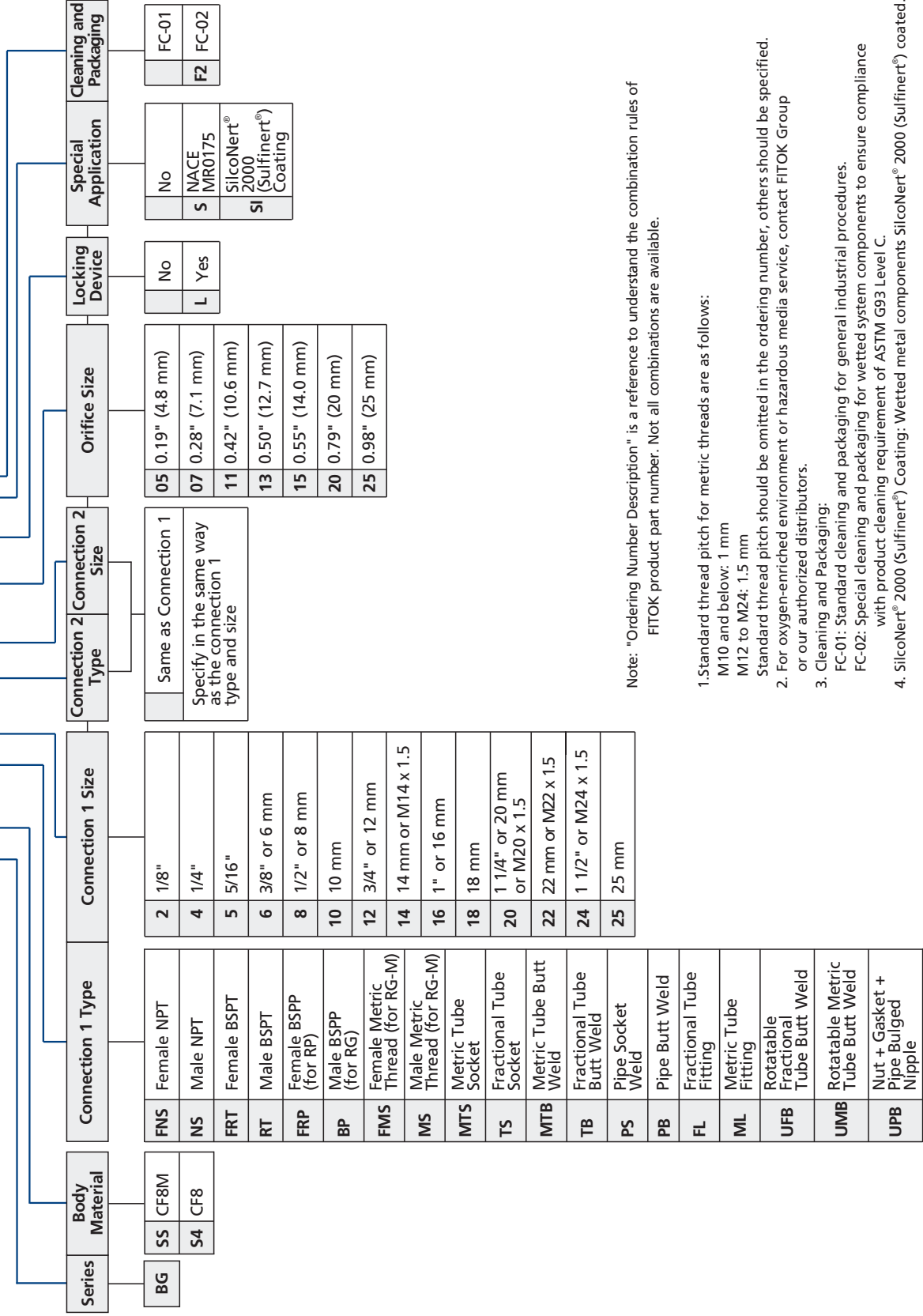

Note: "Ordering Number Description" is a reference to understand the combination rules of FITOK product part number. Not all combinations are available.

- Standard thread pitch for metric threads are as follows:
M10 and below: 1 mm
M12 to M24: 1.5 mm
Standard thread pitch should be omitted in the ordering number, others should be specified.
- For oxygen-enriched environment or hazardous media service, contact FITOK Group or our authorized distributors.
- Cleaning and Packaging:
FC-01: Standard cleaning and packaging for general industrial procedures.
FC-02: Special cleaning and packaging for wetted system components to ensure compliance with product cleaning requirement of ASTM G93 Level C.
- SilcoNert® 2000 (Sulfinert®) Coating: Wetted metal components SilcoNert® 2000 (Sulfinert®) coated.

3-piece Ball Valves

BH Series

Features

- ⦿ Working pressure up to: 3000 psig (207 bar)
- ⦿ Working temperature: -20°F to 450°F (-28°C to 232°C)
- ⦿ End connections:
 - 1/8 to 2 thread
 - 1/8" to 2" pipe butt or socket weld
 - 1/4" to 2" and 6 mm to 50 mm tube butt or socket weld
 - 1/4" to 2" and 6 mm to 38 mm tube fitting
- ⦿ 3-piece precision cast body construction
- ⦿ Orifize sizes: 0.19" (4.8 mm) to 1.5" (38.1 mm)
- ⦿ Pneumatic and electric actuator available
- ⦿ Bidirectional flow for 2-way valves
- ⦿ Bottom port as inlet for 3-way valves
- ⦿ Leak-tight performance testing with nitrogen or compressed air for every valve at the rated pressure to meet the requirement of no visible leak

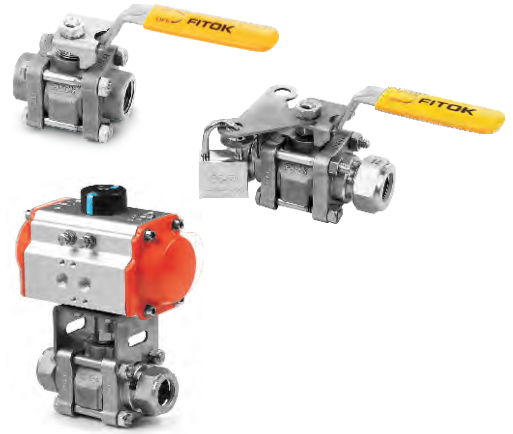

Pressure vs. Temperature

2-way Valves

Orifice Size: 0.19", 0.28", 0.41", 0.52" & 0.88"

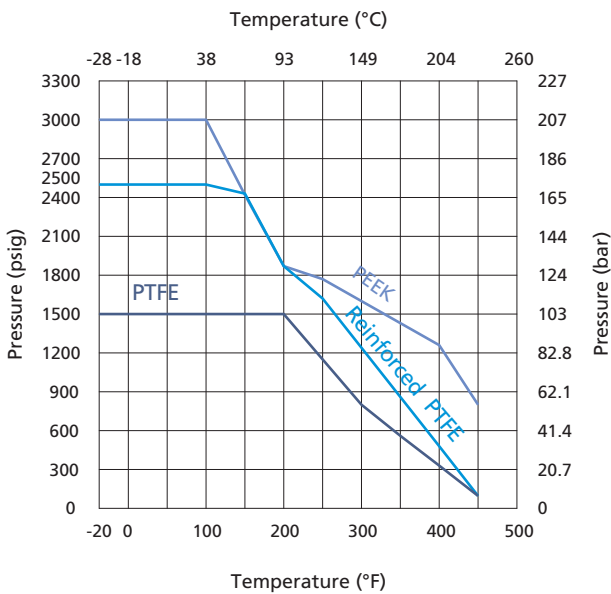

Orifice Size: 1.13", 1.25" & 1.50"

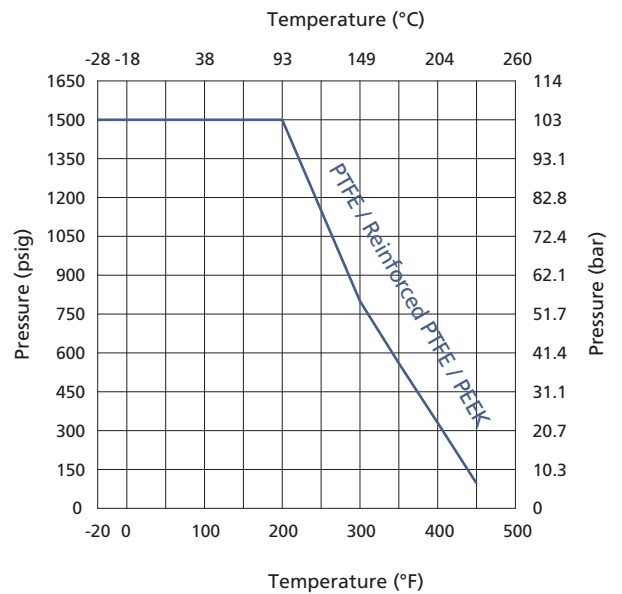

3-way Valves

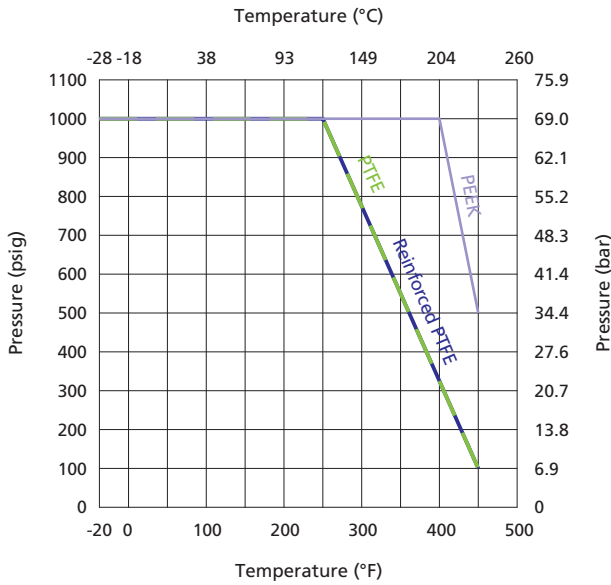

Note: The temperature and pressure rating are based on valves of standard materials.

Standard Materials of Construction

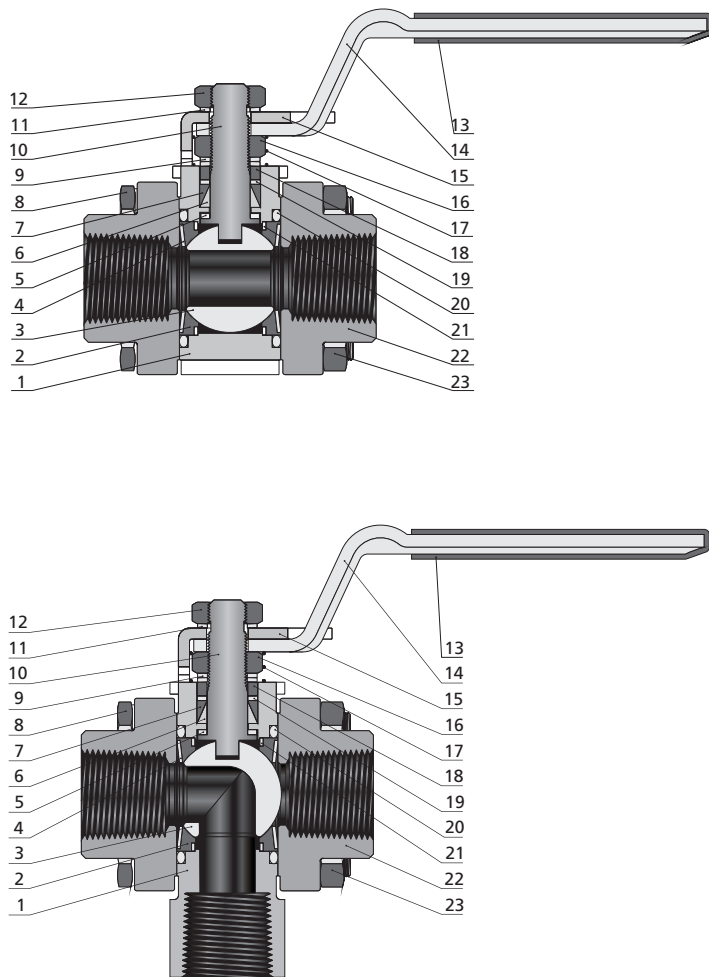

Item	Component	Material Grade/ASME Specification	
1	Body	<i>CF8M/A351</i>	<i>CF8/A351</i>
2	Seat	<i>PTFE or Reinforced PTFE or PEEK</i>	
3	Ball	<i>316 SS/A479</i>	
4	Coned-disc Spring	<i>Strain-hardened 316 SS/A240</i>	
5	Stem Bearing	<i>PEEK</i>	
6	Lower Packing	<i>Reinforced PTFE</i>	
7	Upper Packing	<i>Reinforced PTFE</i>	
8	Body Bolt	<i>Gr. B8M/A193</i>	
9	Stem Spring	<i>Strain-hardened 316 SS/A240</i>	
10	Stem	<i>316 SS/A479</i>	
11	Stem Spring	<i>Strain-hardened 316 SS/A240</i>	
12	Stem Nut	<i>Gr. 8M/A194</i>	
13	Handle Sleeve	<i>Vinyl</i>	
14	Handle	<i>304 SS/A240</i>	
15	Stop Plate	<i>304 SS/A240</i>	
16	Stem Nut	<i>Gr. 8M/A194</i>	
17	Grounding Spring	<i>302 SS/A313</i>	
18	Gland	<i>PTFE-coated 316 SS/A479</i>	
19	Packing Support	<i>PEEK</i>	
20	Flange Seal	<i>PTFE/ID1710</i>	
21	Support Ring	<i>316 SS/A240</i>	
22	End Connection	<i>CF8M/A351</i>	<i>CF8/A351</i>
23	Body Nut	<i>Gr.8M/A194</i>	
	Lubricants	<i>Silicone-based and PTFE-based</i>	

Note: Wetted components are listed in italics. For other materials, please contact FITOK Group or our authorized distributors.

Dimensions

2-way Valves

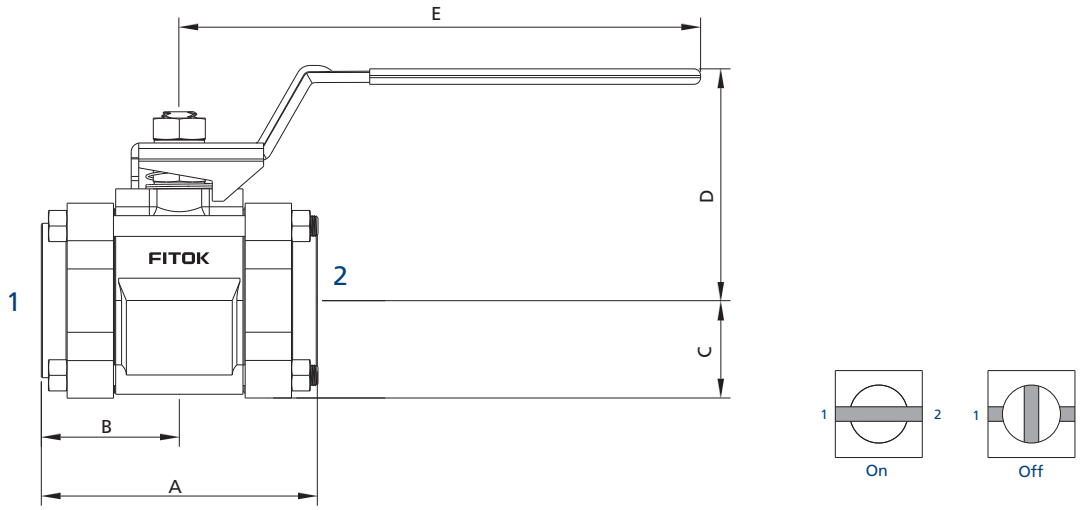

3-way Valves

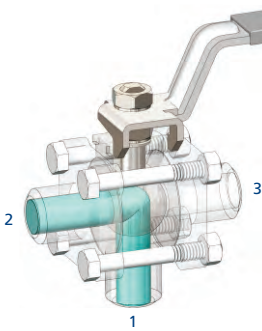
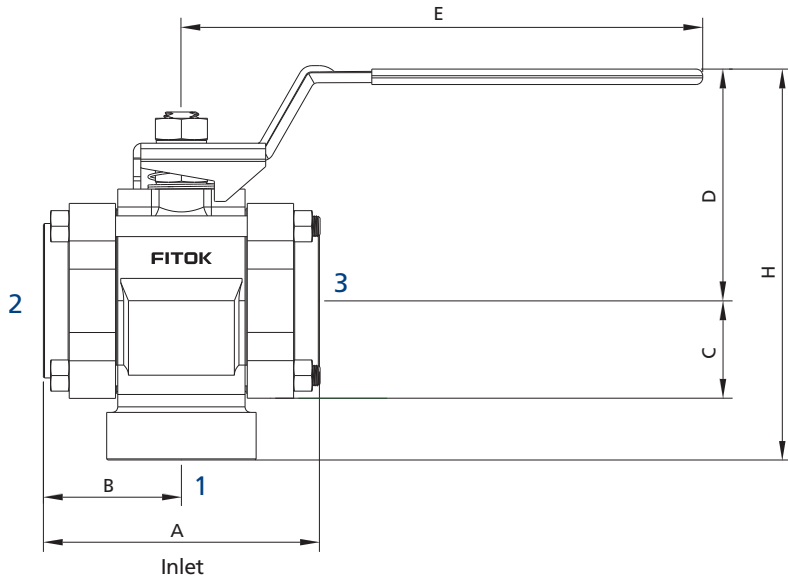

Port 1 to port 2

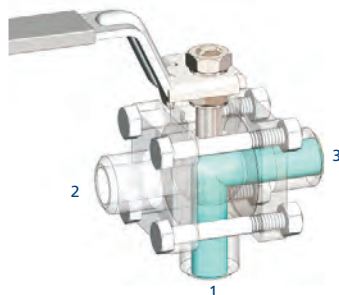

Port 1 to port 3

Basic Ordering Number		Connection Type and Size		Orifice in. (mm)	Cv	Dimensions, in. (mm)										
2-way	3-way	Connection 1	Connection 2/3			A	B	C	D	E	H					
BH□□-FL4-05	BH□□-FL4-05-3	1/4" FITOK	1/4" FITOK	0.19 (4.8)	1.2	3.17 (80.5)	1.59 (40.4)	0.68 (17.3)	1.66 (42.2)	2.37 (60.2)	3.35 (85.1)					
BH□□-ML6-05	BH□□-ML6-05-3	6 mm FITOK	6 mm FITOK		2.5											
BH□□-ML8-05	BH□□-ML8-05-3	8 mm FITOK	8 mm FITOK		1.2	2.16 (54.9)	1.08 (27.4)									
BH□□-TS4-05	—	1/4" TS	1/4" TS			2.08 (52.8)	1.04 (26.4)									
BH□□-MTS6-05	—	6 mm MTS	6 mm MTS			—										
BH□□-PB4-05	—	1/4 PB, Schedule Number: 80	1/4 PB, Schedule Number: 80		0.28 (7.1)	3.8	2.16 (54.9)					1.08 (27.4)	0.68 (17.3)	1.66 (42.2)	2.37 (60.2)	3.12 (79.2)
BH□□-FNS2-07	BH□□-FNS2-07-3	1/8 Female NPT	1/8 Female NPT													
BH□□-FRT2-07	BH□□-FRT2-07-3	1/8 Female BSPT	1/8 Female BSPT													
BH□□-FRP2-07	BH□□-FRP2-07-3	1/8 Female BSPP	1/8 Female BSPP													
BH□□-FNS4-07	BH□□-FNS4-07-3	1/4 Female NPT	1/4 Female NPT													
BH□□-FRT4-07	BH□□-FRT4-07-3	1/4 Female BSPT	1/4 Female BSPT													
BH□□-FRP4-07	BH□□-FRP4-07-3	1/4 Female BSPP	1/4 Female BSPP													
BH□□-FL6-07	BH□□-FL6-07-3	3/8" FITOK	3/8" FITOK	3.17 (80.5)				1.59 (40.4)	4.37 (111)							
BH□□-ML10-07	BH□□-ML10-07-3	10 mm FITOK	10 mm FITOK							3.20 (81.3)	1.60 (40.6)					
BH□□-TS6-07	—	3/8" TS	3/8" TS							2.16 (54.9)	1.08 (27.4)					
BH□□-PB6-07	—	3/8 PB, Schedule Number: 80	3/8 PB, Schedule Number: 80							2.08 (52.8)	1.04 (26.4)					
BH□□-FL8-10	BH□□-FL8-10-3	1/2" FITOK	1/2" FITOK	0.41 (10.4)				7.5	4.04 (103)	2.02 (51.3)	0.89 (22.6)					
BH□□-ML12-10	BH□□-ML12-10-3	12 mm FITOK	12 mm FITOK	0.41 (10.4)												
BH□□-TS8-10	—	1/2" TS	1/2" TS	0.41 (10.4)	2.70 (68.6)	1.34 (34)										
BH□□-FNS6-13	BH□□-FNS6-13-3	3/8 Female NPT	3/8 Female NPT	0.52 (13.1)	12	2.70 (68.6)	1.35 (34.3)	0.89 (22.6)	2.35 (59.7)	4.50 (114)	4.19 (106)					
BH□□-FRT6-13	BH□□-FRT6-13-3	3/8 Female BSPT	3/8 Female BSPT													
BH□□-FRP6-13	BH□□-FRP6-13-3	3/8 Female BSPP	3/8 Female BSPP													
BH□□-FNS8-13	BH□□-FNS8-13-3	1/2 Female NPT	1/2 Female NPT													
BH□□-FRT8-13	BH□□-FRT8-13-3	1/2 Female BSPT	1/2 Female BSPT													
BH□□-FRP8-13	BH□□-FRP8-13-3	1/2 Female BSPP	1/2 Female BSPP													
BH□□-FL12-13	BH□□-FL12-13-3	3/4" FITOK	3/4" FITOK									13.6	4.04 (103)	2.02 (51.3)	4.48 (114)	
BH□□-ML16-13	BH□□-ML16-13-3	16 mm FITOK	16 mm FITOK													
BH□□-ML18-13	BH□□-ML18-13-3	18 mm FITOK	18 mm FITOK													
BH□□-TS12-13	—	3/4" TS	3/4" TS													2.70 (68.6)
BH□□-PS8-13	—	1/2 PS	1/2 PS									15	—			
BH□□-PB8-13	—	1/2 PB, Schedule Number: 80	1/2 PB, Schedule Number: 80									6.8	2.69 (68.3)	1.34 (34)	—	

B-20 Ball Valves

Basic Ordering Number		Connection Type and Size		Orifice in.(mm)	Cv	Dimensions, in. (mm)					
2-way	3-way	Connection 1	Connection 2/3			A	B	C	D	E	H
BH□□-PB12-13	—	3/4 PB, Schedule Number: 80	3/4 PB, Schedule Number: 80	0.52 (13.1)	13.6	2.69 (68.3)	1.34 (34)	0.89 (22.6)	2.35 (59.7)	4.50 (114)	—
BH□□-FNS12-22	BH□□-FNS12-22-3	3/4 Female NPT	3/4 Female NPT	0.88 (22.2)	31	3.59 (91.2)	1.8 (45.7)	1.25 (31.8)	2.94 (74.7)	6.00 (152)	5.45 (138)
BH□□-FRT12-22	BH□□-FRT12-22-3	3/4 Female BSPT	3/4 Female BSPT								
BH□□-FRP12-22	BH□□-FRP12-22-3	3/4 Female BSPP	3/4 Female BSPP								
BH□□-FNS16-22	BH□□-FNS16-22-3	1 Female NPT	1 Female NPT		38	4.45 (113)	2.23 (56.6)				
BH□□-FRT16-22	BH□□-FRT16-22-3	1 Female BSPT	1 Female BSPT								
BH□□-FRP16-22	BH□□-FRP16-22-3	1 Female BSPP	1 Female BSPP		40	5.36 (136)	2.68 (68)				
BH□□-FL16-22	BH□□-FL16-22-3	1" FITOK	1" FITOK								
BH□□-FL20-22	BH□□-FL20-22-3	1 1/4" FITOK	1 1/4" FITOK								
BH□□-ML25-22	BH□□-ML25-22-3	25 mm FITOK	25 mm FITOK		40	5.36 (136)	2.68 (68)				
BH□□-ML28-22	BH□□-ML28-22-3	28 mm FITOK	28 mm FITOK								
BH□□-TS16-22	—	1" TS	1" TS		38	3.59 (91.2)	1.80 (45.7)				
BH□□-MTS25-22	—	25 mm MTS	25 mm MTS								
BH□□-PS12-22	—	3/4 PS	3/4 PS								
BH□□-PS16-22	—	1 PS	1 PS		42	3.59 (91.2)	1.80 (45.7)				
BH□□-PB16-22	—	1 PB Schedule Number: 80	1 PB Schedule Number: 80		40	3.46 (87.9)	1.73 (43.9)				1.25 (31.8)
BH□□-TS20-29	—	1 1/4" TS	1 1/4" TS	1.13 (28.6)	80	4.39 (112)	2.19 (55.6)	1.53 (38.9)	4.03 (102)	9.14 (232)	—
BH□□-PB20-32	—	1 1/4 PB, Schedule Number: 80	1 1/4 PB, Schedule Number: 80								
BH□□-FNS20-32	BH□□-FNS20-32-3	1 1/4 Female NPT	1 1/4 Female NPT	1.25 (31.8)	90	4.39 (112)	2.19 (55.6)	1.53 (38.9)	4.03 (102)	9.14 (232)	6.86 (174)
BH□□-FNS24-32	BH□□-FNS24-32-3	1 1/2 Female NPT	1 1/2 Female NPT								
BH□□-TS24-32	—	1 1/2" TS	1 1/2" TS								
BH□□-PS20-32	—	1 1/4 PS	1 1/4 PS		90	4.51 (115)	2.25 (57.2)				
BH□□-PS24-32	—	1 1/2 PS	1 1/2 PS								
BH□□-PB24-32	—	1 1/2 PB, Schedule Number: 80	1 1/2 PB, Schedule Number: 80	100	4.57 (116)	2.28 (57.9)					
BH□□-FNS32-38	BH□□-FNS32-38-3	2 Female NPT	2 Female NPT	1.50 (38.1)	130	4.94 (125)	2.47 (62.5)	1.74 (44.2)	4.16 (106)	9.14 (232)	7.21 (183)
BH□□-FRT32-38	BH□□-FRT32-38-3	2 Female BSPT	2 Female BSPT								
BH□□-TS32-38	—	2" TS	2" TS								
BH□□-PS32-38	—	2 PS	2 PS								
BH□□-PB32-38	—	2 PB, Schedule Number: 80	2 PB, Schedule Number: 80								

1. FITOK means FITOK double ferrule tube fittings, TS means fractional tube socket weld, MTS means metric tube socket weld, TB means fractional tube butt weld, MTB means metric tube butt weld, PS means pipe socket weld, and PB means pipe butt weld.
2. Sizes and types listed are standard. Other sizes and types are available upon request, please contact FITOK Group or our authorized distributors.
3. Dimensions are shown with tube fitting nuts finger-tightened. All dimensions are for reference only and are subject to change. For dimensions not shown above, please contact FITOK Group or our authorized distributors.

Ordering Number Description

BHS4 - FNS8 - FRT8 - FL8 - P13G - OHQ3L - SCEF2

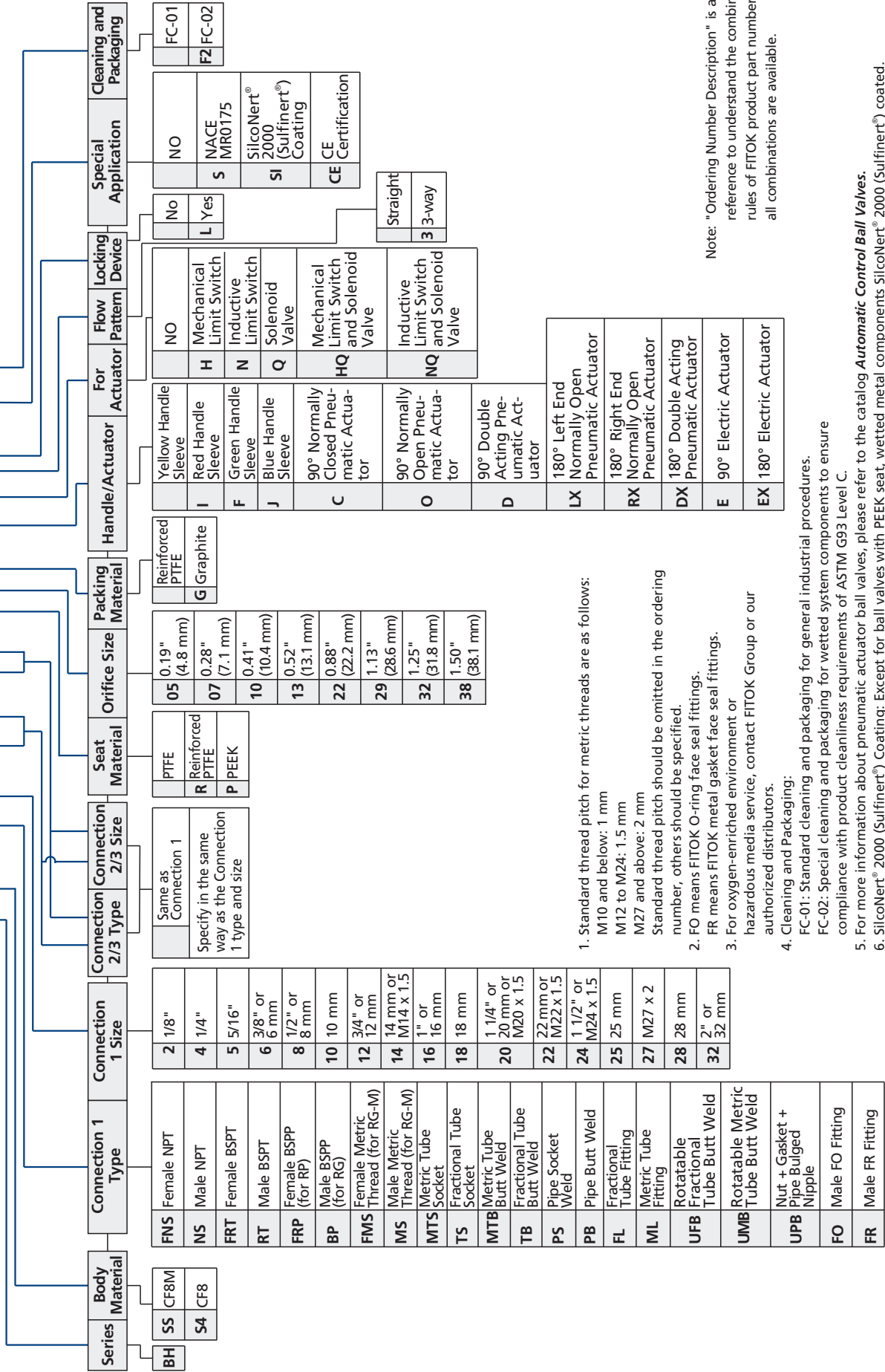

Series	Body Material	Connection 1 Type	Connection 1 Size	Connection 2/3 Type	Connection 2/3 Size	Seat Material	Orifice Size	Packing Material	Handle/Actuator	For Actuator	Flow Locking Device	Special Application	Cleaning and Packaging
BH	SS CF8M	FNS Female NPT	2 1/8"		Same as Connection 1	PTFE	05 0.19" (4.8 mm)	Reinforced PTFE	Yellow Handle Sleeve	NO	NO	NO	FC-01
	S4 CF8	MS Male NPT	4 1/4"		Specify in the same way as the Connection 1 type and size	R Reinforced PTFE	07 0.28" (7.1 mm)	G Graphite	I Red Handle Sleeve	H Mechanical Limit Switch	L Yes	NACE MR0175	F2 FC-02
		FRT Female BSPT	5 5/16"			P PEEK	10 0.41" (10.4 mm)		F Green Handle Sleeve	N Inductive Limit Switch		SilcoNert® 2000 (Sulfinert®) Coating	
		RT Male BSPT	3/8" or 6 mm				13 0.52" (13.1 mm)		J Blue Handle Sleeve	Q Solenoid Valve		CE Certification	
		FRP Female BSPP	1/2" or 8 mm				22 0.88" (22.2 mm)		C 90° Normally Closed Pneumatic Actuator	HQ Mechanical Limit Switch and Solenoid Valve			
		BP Male BSPP (for RG)	10 10 mm				29 1.13" (28.6 mm)		O 90° Normally Open Pneumatic Actuator	NQ Inductive Limit Switch and Solenoid Valve			
		FMS Female Metric Thread (for RG-M)	3/4" or 12 mm				32 1.25" (31.8 mm)		D 90° Double Acting Pneumatic Actuator				
		MS Male Metric Thread (for RG-M)	14 mm or M14 x 1.5				38 1.50" (38.1 mm)		LX 180° Left End Normally Open Pneumatic Actuator				
		MTS Metric Tube Socket	1" or 16 mm						RX 180° Right End Normally Open Pneumatic Actuator				
		TS Fractional Tube Socket	18 18 mm						DX 180° Double Acting Pneumatic Actuator				
		MTB Metric Tube Butt Weld	1 1/4" or 20 mm or M20 x 1.5						E 90° Electric Actuator				
		TB Fractional Tube Butt Weld	22 mm or M22 x 1.5						EX 180° Electric Actuator				
		PS Pipe Socket Weld	24 1 1/2" or M24 x 1.5										
		PB Pipe Butt Weld	25 25 mm										
		FL Fractional Tube Fitting	27 M27 x 2										
		ML Metric Tube Fitting	28 28 mm										
		UFB Rotatable Fractional Tube Butt Weld	2" or 32 mm										
		UIMB Rotatable Metric Tube Butt Weld											
		UPB Nut + Gasket + Pipe Bulged Nipple											
		FO Male FO Fitting											
		FR Male FR Fitting											

- Standard thread pitch for metric threads are as follows:
M10 and below: 1 mm
M12 to M24: 1.5 mm
M27 and above: 2 mm
Standard thread pitch should be omitted in the ordering number, others should be specified.
- FO means FITOK O-ring face seal fittings.
FR means FITOK metal gasket face seal fittings.
- For oxygen-enriched environment or hazardous media service, contact FITOK Group or our authorized distributors.
- Cleaning and Packaging:
FC-01: Standard cleaning and packaging for general industrial procedures.
FC-02: Special cleaning and packaging for wetted system components to ensure compliance with product cleanliness requirements of ASTM G93 Level C.

Note: "Ordering Number Description" is a reference to understand the combination rules of FITOK product part number. Not all combinations are available.

- For more information about pneumatic actuator ball valves, please refer to the catalog **Automatic Control Ball Valves**.
- SilcoNert® 2000 (Sulfinert®) Coating: Except for ball valves with PEEK seat, wetted metal components SilcoNert® 2000 (Sulfinert®) coated.
- CE certification is available. For more information, please contact FITOK group or our authorized distributors

One-piece Instrumentation Ball Valves

BO Series

Features

- ⊙ Working pressure up to: 3000 psig (207 bar)
- ⊙ Working temperature: -65°F to 300°F (-54°C to 148°C)
- ⊙ End connections:
1/4 to 1/2 thread
1/16" to 3/4" and 3 mm to 18 mm tube fitting
- ⊙ 2-, 3-, 4-, 5-, 6- and 7-way models for on-off, switching and crossover service available
- ⊙ One-piece body and one-piece ball stem
- ⊙ No dead space
- ⊙ Top-loaded design to allow adjustment with the valve in-line
- ⊙ Thermal cycle performance improved and wear compensated by live-loaded design
- ⊙ Any reasonable connections available
- ⊙ Pneumatic and electric actuator available
- ⊙ Handle color options available
- ⊙ Full operating pressure at any port
- ⊙ Leak-tight performance testing with nitrogen or compressed air for every valve at the rated pressure to meet the requirement of no visible leak
- ⊙ The inlet can be any port except for valves with vent ports



Note:

1. To prevent seat leakage, packing adjustment may be required periodically during the service life of the valve.
2. A higher initial actuation torque may happen to the valves that have not been cycled for a period of time.
3. Before installation, instrumentation ball valves exposed to dynamic temperature conditions may lose their initial packing load. Stem packing adjustment should be required.

Standard Materials of Construction

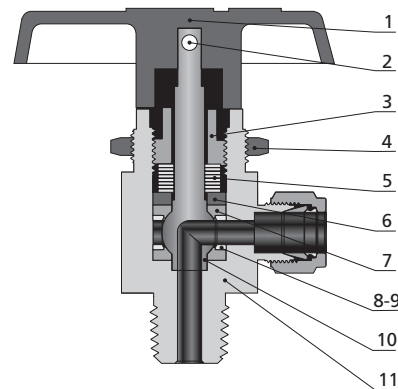
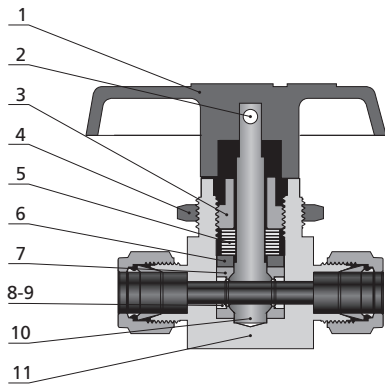

Item	Component	Valve Body Material		
		316 SS	Brass	Alloy 400
		Material Grade/ASTM Specification		
1	Handle	Nylon or Aluminium		
2	Set Screw	Galvanized carbon steel		
3	Packing Bolt	316 SS/A479	Brass C36000/B16	Alloy 400/B164
4	Panel Nut	316 SS/A479	Brass C36000/B16	316 SS/A479
5	Disc Spring	S17700/A693		
6	Gland	316 SS/A479	316 SS/A479	Alloy 400/B164
7	<i>Packing Seat</i>	<i>PTFE/D1710 or UHMWPE/D4020 or PFA/D3307</i>		
8	<i>Support Ring</i>	316 SS/A479	316 SS/A479	Alloy 400/B164
9	<i>Support Disc</i>			
10	<i>Ball Stem</i>	316 SS/A479	Brass C36000/B16	Alloy 400/B164
11	<i>Body</i>	316 SS/A182	Brass C37700/B283	Alloy 400/B164
<i>Wetted Lubricant</i>		<i>Fluorinated-based and silicone-based</i>		
Non-wetted Lubricant		Molybdenum disulfide with hydrocarbon binder coat		

Note: Wetted components are listed in italics.
For other materials, please contact FITOK Group or our authorized distributors.

On-Off (2-way) Valves

Standard Flow Path

Straight Pattern



Angle Pattern



Pressure vs. Temperature

Straight Pattern and Angle Pattern

PTFE Packing Seat

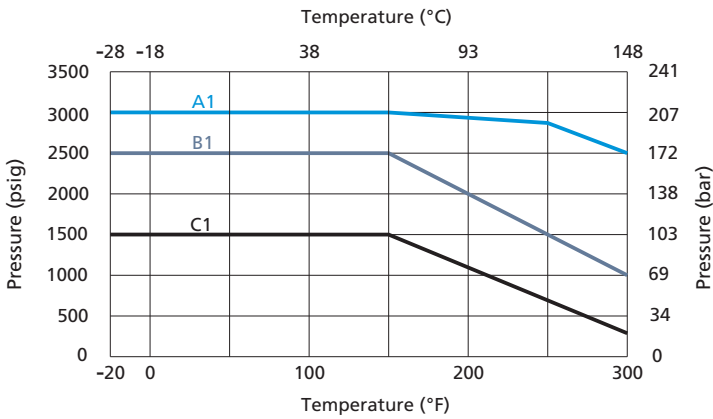

- A1: Straight Pattern Valves (orifice 0.19")
- B1: Straight Pattern Valves (orifice 0.05" & 0.06" & 0.09" & 0.13" & 0.28" & 0.41")
Angle Pattern Valves (orifice 0.05" & 0.06" & 0.09" & 0.13" & 0.19")
- C1: Angle Pattern Valves (orifice 0.28" & 0.41")

PFA, UHMWPE Packing Seat

The working temperature of UHMWPE packing seat should not be higher than 150°F (65°C).

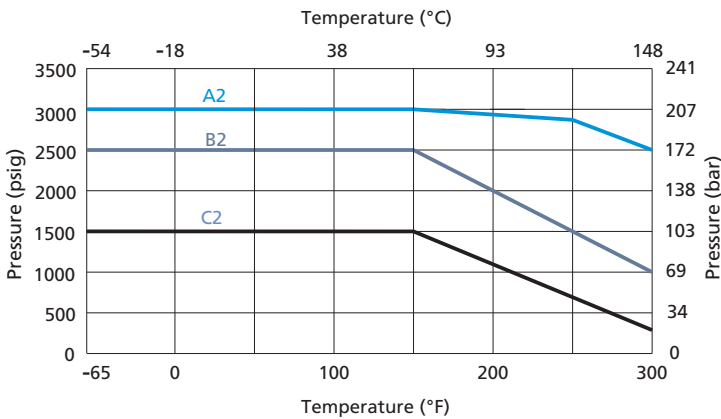

- A2: Straight Pattern Valves (orifice 0.19")
- B2: Straight Pattern Valves (orifice 0.05" & 0.06" & 0.09" & 0.13" & 0.28" & 0.41")
Angle Pattern Valves (orifice 0.05" & 0.06" & 0.09" & 0.13" & 0.19")
- C2: Angle Valves (orifice 0.28" & 0.41")

Dimensions

Straight Pattern

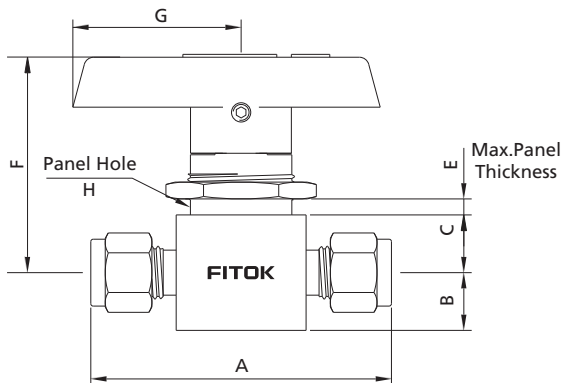

Angle Pattern

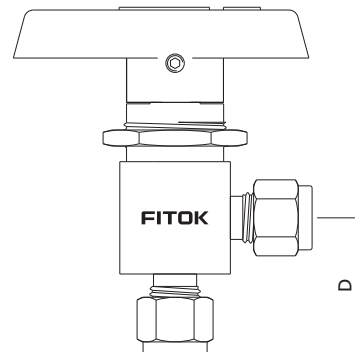

Basic Ordering Number	Connection Type and Size	Orifice in. (mm)	Cv		Dimensions, in. (mm)								
			Straight	Angle	A	B	C	D	E	F	G	H	
BO□□-FL1-00	1/16" FITOK	0.05 (1.3)	0.10	—	1.68 (42.7)				—				
BO□□-FL2-02	1/8" FITOK	0.09 (2.4)	0.20	0.15	2.01 (51.1)	0.28 (7.1)	0.34 (8.6)	0.97 (24.6)	0.25 (6.4)	1.43 (36.2)	1.10 (28)	19/32 (15.1)	
BO□□-FL4-03	1/4" FITOK	0.13 (3.2)	0.60	0.35	2.21 (56.1)			1.07 (27.2)					
BO□□-FL4-05		0.19 (4.8)	1.40	0.90	2.39 (60.7)	0.38 (9.7)	0.44 (11.2)	1.17 (29.7)	0.19 (4.8)	1.64 (41.7)	1.57 (39.9)	25/32 (19.8)	
BO□□-FL6-05	3/8" FITOK		1.50		2.58 (65.5)			1.29 (32.8)					
BO□□-FL6-07		0.28 (7.1)	6.00	2.00	3.05 (77.5)	0.56 (14.2)	0.56 (14.2)	1.43 (36.3)	0.35 (9)	2.19 (55.5)	2.05 (52)	1 1/8 (28.6)	
BO□□-FL8-10	1/2" FITOK	0.41 (10.3)	6.40	3.80	3.92 (99.6)	0.69 (17.5)	0.69 (17.5)	1.74 (44.2)	0.49 (12.5)	2.67 (67.7)	3.13 (79.6)	1 1/2 (38.1)	
BO□□-FL12-10	3/4" FITOK		12.00	4.60									
BO□□-ML3-02	3 mm FITOK	0.09 (2.4)	0.20	0.15	2.01 (51.1)	0.28 (7.1)	0.34 (8.6)	0.97 (24.6)	0.25 (6.4)	1.43 (36.2)	1.10 (28)	19/32 (15.1)	
BO□□-ML6-03	6 mm FITOK	0.13 (3.2)	0.60	0.35	2.21 (56.1)			1.07 (27.2)					
BO□□-ML6-05		0.19 (4.8)	1.40	0.90	2.39 (60.7)	0.38 (9.7)	0.44 (11.2)	1.17 (29.7)	0.19 (4.8)	1.64 (41.7)	1.57 (39.9)	25/32 (19.8)	
BO□□-ML8-05	8 mm FITOK		1.50		2.46 (62.5)			1.20 (30.5)					
BO□□-ML10-07	10 mm FITOK	0.28 (7.1)	6.00	2.00	3.07 (78.0)	0.56 (14.2)	0.56 (14.2)	1.43 (36.3)	0.35 (9)	2.19 (55.5)	2.05 (52)	1 1/8 (28.6)	
BO□□-ML12-10	12 mm FITOK	0.41 (10.3)	12.00	4.60	3.92 (99.6)	0.69 (17.5)	0.69 (17.5)	1.74 (44.2)	0.49 (12.5)	2.67 (67.7)	3.13 (79.6)	1 1/2 (38.1)	
BO□□-FNS2-03	1/8 Female NPT	0.13 (3.2)	0.50	0.30	1.63 (41.4)	0.28 (7.1)	0.34 (8.6)	0.81 (20.6)	0.25 (6.4)	1.43 (36.2)	1.10 (28)	19/32 (15.1)	
BO□□-FNS2-05		0.19 (4.8)	1.20	0.70	2.00 (50.8)	0.38 (9.7)	0.44 (11.2)	1.00 (25.4)	0.19 (4.8)	1.64 (41.7)	1.57 (39.9)	25/32 (19.8)	
BO□□-FNS4-05	1/4 Female NPT		0.90	0.75	2.06 (52.3)			1.03 (26.2)					
BO□□-FNS4-07		0.28 (7.1)	3.00	1.70	2.50 (63.5)	0.56 (14.2)	0.56 (14.2)	1.25 (31.8)	0.35 (9)	2.19 (55.5)	2.05 (52)	1 1/8 (28.6)	
BO□□-FNS6-07	3/8 Female NPT		2.60	1.50									
BO□□-FNS8-10	1/2 Female NPT	0.41 (10.3)	6.30	3.50	3.12 (79.2)	0.69 (17.5)	0.69 (17.5)	1.56 (39.6)	0.49 (12.5)	2.67 (67.7)	3.13 (79.6)	1 1/2 (38.1)	
BO□□-NS4-05	1/4 Male NPT	0.19 (4.8)	1.20	0.75	2.00 (50.8)	0.38 (9.7)	0.44 (11.2)	1.03 (26.2)	0.19 (4.8)	1.64 (41.7)	1.57 (39.9)	25/32 (19.8)	
BO□□-FRT4-05	1/4 Female BSPT		0.90			2.06 (52.3)							
BO□□-FRT6-07	3/8 Female BSPT	0.28 (7.1)	2.60	—	2.50 (63.5)	0.56 (14.2)	0.56 (14.2)	—	0.35 (9)	2.19 (55.5)	2.05 (52)	1 1/8 (28.6)	
BO□□-FRT8-10	1/2 Female BSPT	0.41 (10.3)	6.30	—	3.12 (79.2)	0.69 (17.5)	0.69 (17.5)	—	0.49 (12.5)	2.67 (67.7)	3.13 (79.6)	1 1/2 (38.1)	
BO□□-FO4-03	1/4 Male FO	0.13 (3.2)	0.60	0.35	1.75 (44.4)		0.34 (8.6)	0.94 (23.9)	0.25 (6.4)	1.43 (36.2)	1.10 (28)	19/32 (15.1)	
BO□□-FO4-05		0.19 (4.8)	2.40	0.90	1.88 (47.8)	0.38 (9.7)	0.44 (11.2)		0.19 (4.8)	1.64 (41.7)	1.57 (39.9)	25/32 (19.8)	
BO□□-FR4-03	1/4 Male FR	0.13 (3.2)	0.60	0.35	2.13 (54.1)		0.34 (8.6)	1.09 (27.7)	0.25 (6.4)	1.43 (36.2)	1.10 (28)	19/32 (15.1)	
BO□□-FR4-05		0.19 (4.8)	2.40	0.90			0.44 (11.2)		0.19 (4.8)	1.64 (41.7)	1.57 (39.9)	25/32 (19.8)	
BO□□-FR8-07	1/2 Male FR	0.28 (7.1)	6.00	—	2.88 (73.2)	0.56 (14.2)	—	—	0.35 (9)	2.19 (55.5)	2.05 (52)	1 1/8 (28.6)	
BO□□-FR8-10		0.41 (10.3)	12.00	—	3.12 (79.2)	0.69 (17.5)	—	—	0.49 (12.5)	2.67 (67.7)	3.13 (79.6)	1 1/2 (38.1)	

Switching (3-, 4-, 5-, 6- and 7-way) Valves

Standard Flow Path

3-way Valves

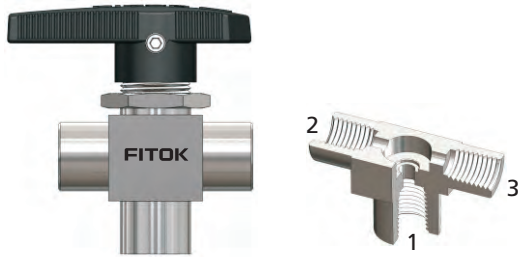

4-way Valves

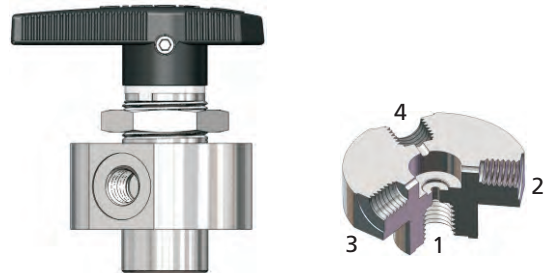

3L Flow Path

This type of valve can connect one side port to the bottom port or shut off 3 ports. Switch between 0°, 90° and 180° positions with 180° rotation handle.

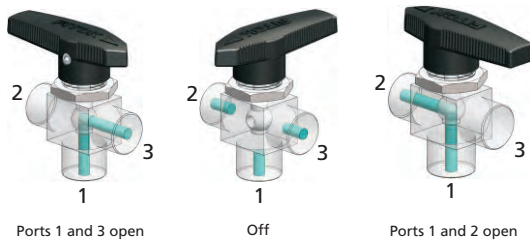

4L Flow Path

This type of valve can connect one side port to the bottom port, and shut off other 2 side ports at the same time. Switching can be done in 120° increments with 360° rotation handle.



5-way Valves

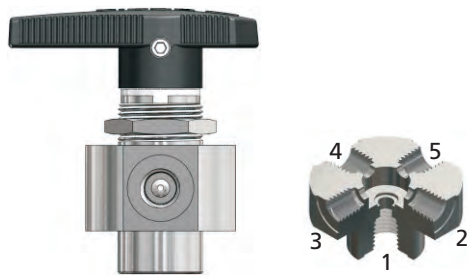

5L Flow Path

This type of valve can connect one side port to the bottom port, and shut off other 3 side ports at the same time. Switching can be done in 90° increments with 360° rotation handle.

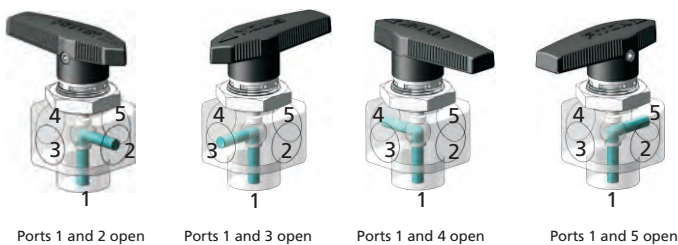

6-way Valves

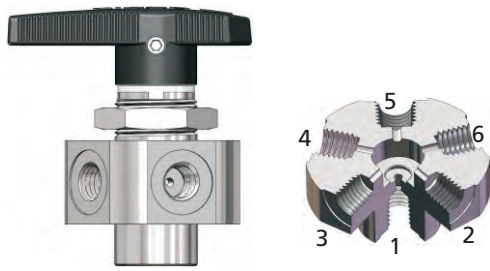

6L Flow Path

This type of valve can connect one side port to the bottom port, and shut off other 4 side ports at the same time. Switching can be done in 72° increments with 360° rotation handle.

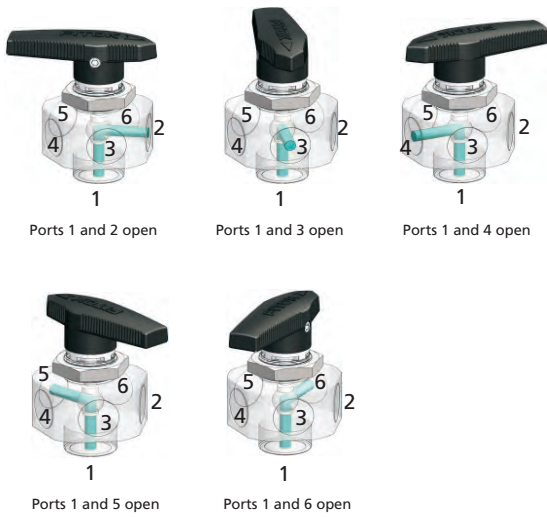

7-way Valves

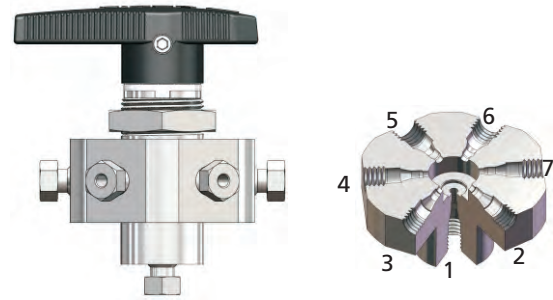

7L Flow Path

This type of valve can connect one side port to the bottom port, and shut off other 5 side ports at the same time. Switching can be done in 60° increments with 360° rotation handle.

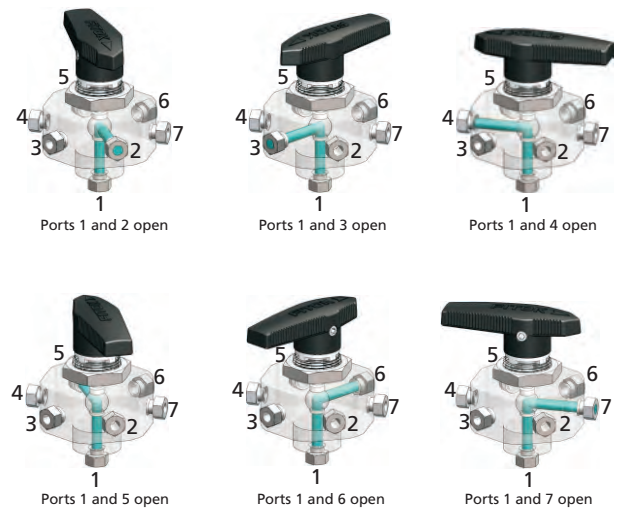

Pressure vs. Temperature

Switching Valves

PTFE Packing Seat

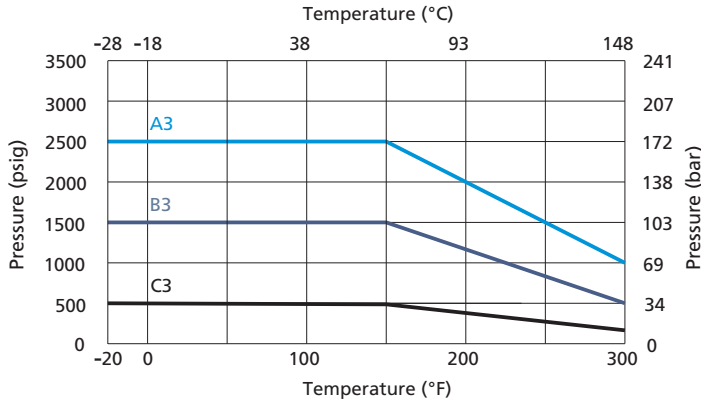

A3: 3-way (orifice 0.05" & 0.06" & 0.09" & 0.13" & 0.19")
4-way / 5-way (orifice 0.06")

B3: 3-way (orifice 0.28" & 0.41")
4-way / 5-way (orifice 0.41")

C3: 6-way / 7-way (orifice 0.05" & 0.06")

PFA, UHMWPE Packing Seat

The working temperature of UHMWPE packing seat should not be higher than 150°F (65°C).

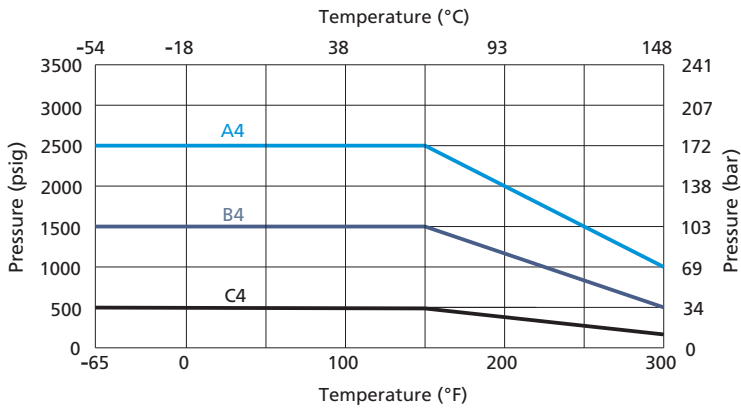

A4: 3-way (orifice 0.05" & 0.06" & 0.09" & 0.13" & 0.19")
4-way / 5-way (orifice 0.06")

B4: 3-way (orifice 0.28" & 0.41")
4-way / 5-way (orifice 0.41")

C4: 6-way / 7-way (orifice 0.05" & 0.06")

Dimensions

3-way Valves

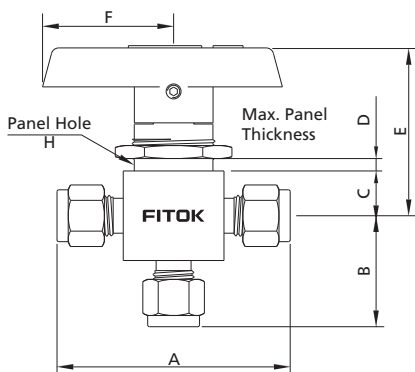

4-and 5-way Valves

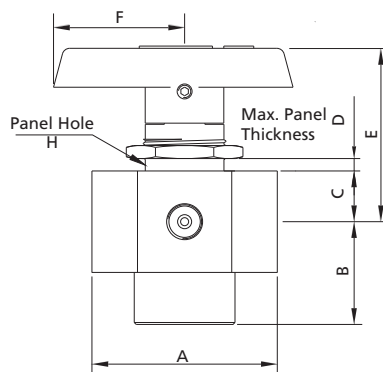

6-and 7-way Valves

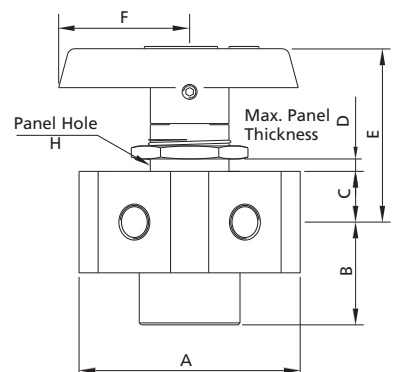

Basic Ordering Number	Connection Type and Size	Orifice in. (mm)	Cv	Dimensions, in. (mm)						
				A	B	C	D	E	F	H
3-way Valves										
BO□□-FL1-00-3L	1/16" FITOK	0.05 (1.3)	0.08	1.68 (42.7)	0.81 (20.6)					
BO□□-FL2-02-3L	1/8" FITOK	0.09 (2.4)	0.15	2.01 (51.1)	0.97 (24.6)	0.34 (8.6)	0.25 (6.4)	1.43 (36.2)	1.10 (28)	19/32 (15.1)
BO□□-FL4-03-3L	1/4" FITOK	0.13 (3.2)	0.35	2.21 (56.1)	1.07 (27.2)					
BO□□-FL4-05-3L		0.19 (4.8)	0.90	2.39 (60.7)	1.17 (29.7)	0.44 (11.2)	0.19 (4.8)	1.64 (41.7)	1.57 (39.9)	25/32 (19.8)
BO□□-FL6-07-3L	3/8" FITOK	0.28 (7.1)	2.00	2.89 (73.4)	1.43 (36.3)	0.56 (14.2)	0.35 (9)	2.19 (55.5)	2.05 (52)	11/8 (28.6)
BO□□-FL8-10-3L	1/2" FITOK	0.41 (10.3)	4.60	3.48 (88.4)	1.74 (44.2)	0.69 (17.5)	0.49 (12.5)	2.67 (67.7)	3.13 (79.6)	11/2 (38.1)
BO□□-FL12-10-3L	3/4" FITOK		4.90							
BO□□-ML3-02-3L	3 mm FITOK	0.09 (2.4)	0.15	2.01 (51.1)	0.97 (24.6)	0.34 (8.6)	0.25 (6.4)	1.43 (36.2)	1.10 (28)	19/32 (15.1)
BO□□-ML6-03-3L	6 mm FITOK	0.13 (3.2)	0.35	2.21 (56.1)	1.07 (27.2)					
BO□□-ML6-05-3L		8 mm FITOK	0.19 (4.8)	0.90	2.39 (60.7)	1.17 (29.7)	0.44 (11.2)	0.19 (4.8)	1.64 (41.7)	1.57 (39.9)
BO□□-ML8-05-3L	0.80			2.46 (62.5)	1.20 (30.5)					
BO□□-ML10-07-3L	10 mm FITOK	0.28 (7.1)	2.00	2.89 (73.4)	1.43 (36.3)	0.56 (14.2)	0.35 (9)	2.19 (55.5)	2.05 (52)	1 1/8 (28.6)
BO□□-ML12-10-3L	12 mm FITOK	0.41 (10.3)	4.60	3.48 (88.4)	1.74 (44.2)	0.69 (17.5)	0.49 (12.5)	2.67 (67.7)	3.13 (79.6)	1 1/2 (38.1)
BO□□-FNS2-03-3L	1/8 Female NPT	0.13 (3.2)	0.30	1.63 (41.4)	0.81 (20.6)	0.34 (8.6)	0.25 (6.4)	1.43 (36.2)	1.10 (28)	19/32 (15.1)
BO□□-FNS4-05-3L	1/4 Female NPT	0.19 (4.8)	0.75	2.06 (52.3)	1.03 (26.2)	0.44 (11.2)	0.19 (4.8)	1.64 (41.7)	1.57 (39.9)	25/32 (19.8)
BO□□-FNS4-07-3L		0.28 (7.1)	1.70	2.5 (63.5)	1.18 (30)	0.56 (14.2)	0.35 (9)	2.19 (55.5)	2.05 (52)	1 1/8 (28.6)
BO□□-FNS6-07-3L	3/8 Female NPT		1.50							
BO□□-FNS8-10-3L	1/2 Female NPT	0.41 (10.3)	3.50	3.13 (79.5)	1.56 (39.6)	0.69 (17.5)	0.49 (12.5)	2.67 (67.7)	3.13 (79.6)	1 1/2 (38.1)
BO□□-FRT4-05-3L	1/4 Female BSPT	0.19 (4.8)	0.75	2.06 (52.3)	1.03 (26.2)	0.44 (11.2)	0.19 (4.8)	1.64 (41.7)	1.57 (39.9)	25/32 (19.8)
BO□□-FRT6-07-3L	3/8 Female BSPT	0.28 (7.1)	1.50	2.5 (63.5)	1.18 (30)	0.56 (14.2)	0.35 (9)	2.19 (55.5)	2.05 (52)	1 1/8 (28.6)
BO□□-FRT8-10-3L	1/2 Female BSPT	0.41 (10.3)	3.50	3.13 (79.5)	1.56 (39.6)	0.69 (17.5)	0.49 (12.5)	2.67 (67.7)	3.13 (79.6)	1 1/2 (38.1)
4 - & 5-way Valves										
BO□□-FL2-01-4L	1/8" Female FITOK Tube Fitting	0.06 (1.6)	0.07	2.36 (60)	1.32 (33.5)	0.44 (11.2)	0.20 (5.2)	1.76 (44.6)	1.57 (39.9)	29/32 (23.1)
BO□□-FL2-01-5L				1.85 (47)	0.88 (22.4)					
BO□□-FNS2-01-4L	1/8 Female NPT	0.06 (1.6)	0.07	1.55 (39.4)						
BO□□-FNS2-01-5L										
BO□□-FNS8-10-4L	1/2 Female NPT	0.41 (10.3)	3.50	3.13 (79.5)	1.56 (39.6)	0.69 (17.5)	0.41 (10.5)	2.67 (70.2)	2.63 (66.7)	1 1/2 (38.1)
BO□□-FNS8-10-5L										
6 - & 7-way Valves										
BO□□-FL1-00-6L	1/16" Female FITOK Tube Fitting	0.05 (1.3)	0.05	2.64 (67)	1.32 (33.5)	0.44 (11.2)	0.28 (7)	1.76 (44.6)	1.57 (39.9)	29/32 (23.1)
BO□□-FL1-00-7L										
BO□□-FL2-01-6L	1/8" Female FITOK Tube Fitting	0.06 (1.6)	0.07	2.26 (57.6)	0.97 (24.7)					
BO□□-FL2-01-7L										

Crossover (4-, 6-way) Valves

Standard Flow Path

4-way Valves

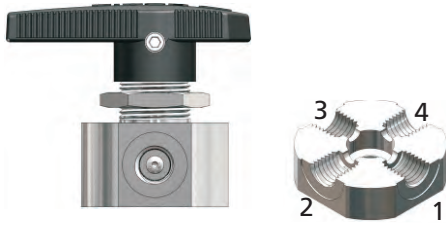

6-way Valves

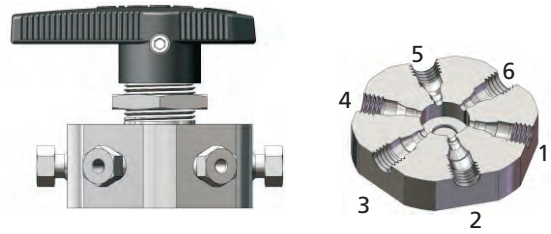

4C Flow Path

This type of valve can connect two groups of adjacent ports at the same time. Switch between 0° and 90° positions with 90° rotation handle.

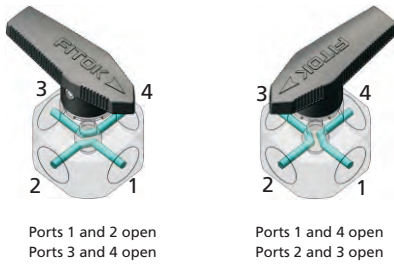

Ports 1 and 2 open
Ports 3 and 4 open

Ports 1 and 4 open
Ports 2 and 3 open

6C Flow Path

This type of valve can connect three groups of adjacent ports at the same time. Switch between 0° and 60° positions with 60° rotation handle.

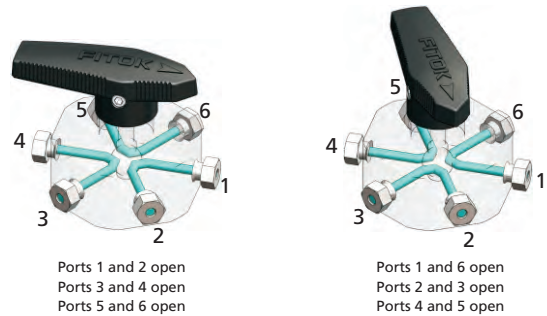

Ports 1 and 2 open
Ports 3 and 4 open
Ports 5 and 6 open

Ports 1 and 6 open
Ports 2 and 3 open
Ports 4 and 5 open

Pressure vs. Temperature

Crossover Valves

PTFE Packing Seat

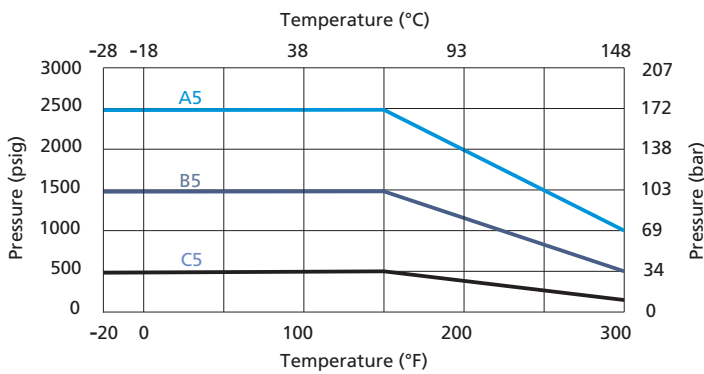

A5: 4-way (orifice 0.06")

B5: 4-way (orifice 0.41")

C5: 6-way (orifice 0.05" & 0.06")

PFA, UHMWPE Packing Seat

The working temperature of UHMWPE packing seat should not be higher than 150°F (65°C).

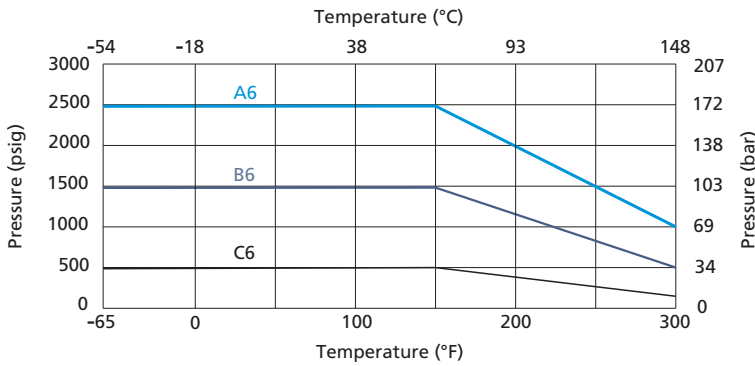

- A6: 4-way (orifice 0.06")
- B6: 6-way (orifice 0.41")
- C6: 6-way (orifice 0.05" & 0.06")

Ball Valves
Plug Valves

Dimensions

4-way Valves

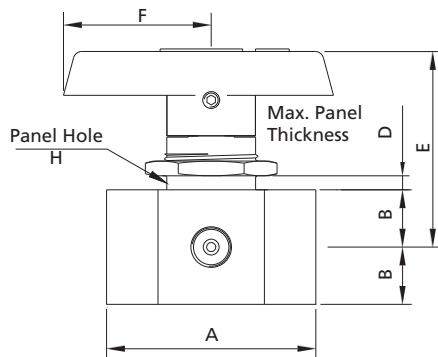

6-way Valves

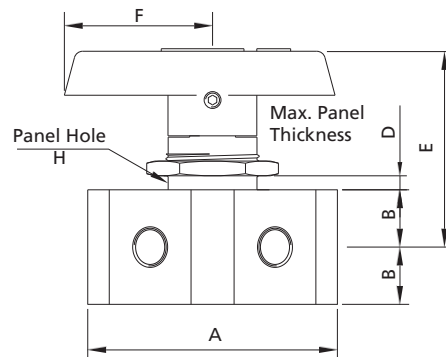

Basic Ordering Number	Connection Type and Size	Orifice in. (mm)	Cv	Dimensions, in. (mm)						
				A	B	D	E	F	H	
4-way Valve										
BO□□-FL1-00-4C	1/16" Female FITOK Tube Fitting	0.05 (1.3)	0.06	1.95 (49.6)						
BO□□-FL2-01-4C	1/8" Female FITOK Tube Fitting	0.06 (1.6)	0.08	2.61 (66.3)	0.44 (11.2)	0.19 (4.8)	1.64 (41.7)	1.57 (39.9)	25/32 (19.8)	
BO□□-FNS2-01-4C	1/8 Female NPT			1.55 (39.4)						
BO□□-FNS8-07-4C	1/2 Female NPT	0.28 (7.1)	1.60	3.13 (79.5)	0.69 (17.5)	0.48 (12.2)	2.67 (67.7)	3.13 (79.6)	1 1/2 (38.1)	
6-way Valve										
BO□□-FL1-00-6C	1/16" Female FITOK Tube Fitting	0.05 (1.3)	0.06	1.95 (49.5)	0.44 (11.2)	0.19 (4.8)	1.68 (42.7)	1.53 (38.9)	29/32 (23.1)	
BO□□-FL2-01-6C	1/8" Female FITOK Tube Fitting	0.06 (1.6)	0.08	2.59 (65.8)						

Note: Connection type for ball valves in 4L, 5L, 6L, 7L, 4C, 6C, 4H, 4HL, 4V, 5HL, 5H and 5LV flow path is female FITOK tube fitting, which can not be used directly with standard FT and MT connections. Please contact FITOK Group or authorized distributors for use with standard FT and MT connections.

1. FITOK means FITOK double ferrule tube fittings.
 2. Sizes and types listed are standard. Other sizes and types are available upon request, please contact FITOK Group or our authorized distributors.
 3. Dimensions are shown with tube fitting nuts finger-tightened. All dimensions are for reference only and are subject to change.
- For dimensions not shown above, please contact FITOK Group or our authorized distributors.

Special Flow Path

3-way Valves



3HL Flow Path

This type of valve can connect one side port to the bottom port, or connect two side ports to the bottom port. Switching can be done in 90° increments with 180° rotation handle.

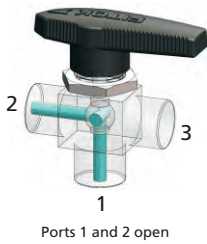
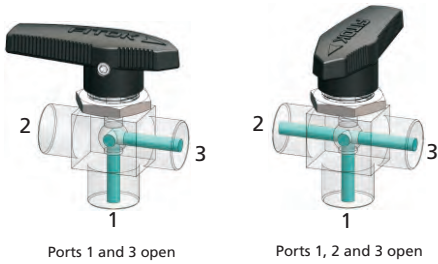

Note: For Temperature VS. Pressure curves and dimensions of 3-way valves, see Switching (3-way) Valves above. For Temperature VS. Pressure curves and dimensions of 4-way valves, see Crossover (4-way) Valves above.

4-way Valves

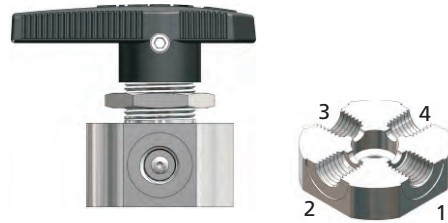

4H Flow Path

This type of valve can connect two opposite ports. Switch between 0° and 90° positions with 90° rotation handle.

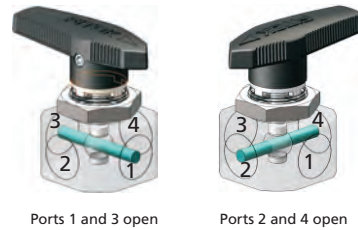

4HL Flow Path

This type of valve can connect three adjacent ports and shut off other ports. Switching can be done in 90° increments with 360° rotation handle.

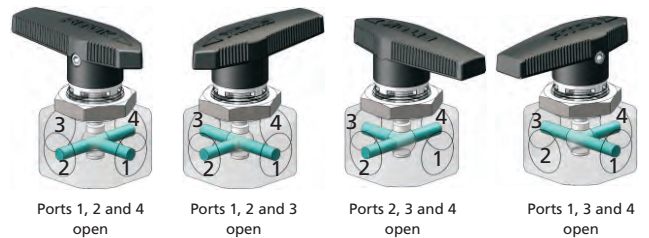

4V Flow Path

This type of valve can connect two adjacent ports and shut off other ports. Switching can be done in 90° increments with 360° rotation handle.

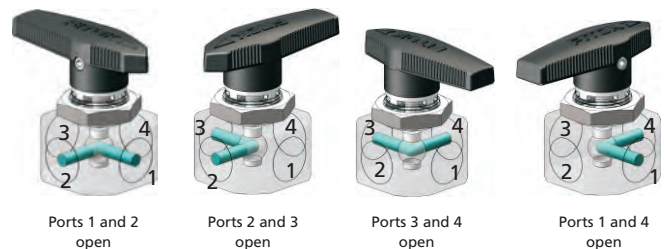

5-way Valves

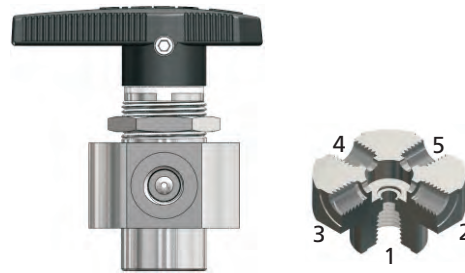

5HL Flow Path

This type of valve can connect three side ports to the bottom port, and shut off the fourth side port at the same time. Switching can be done in 90° increments with 360° rotation handle.

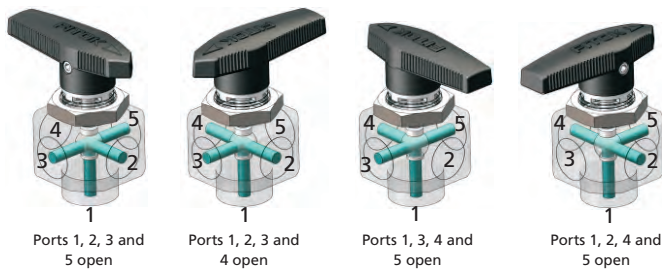

5H Flow Path

This type of valve can connect the bottom port to port 2 and port 4, or connect the bottom port to port 3 and port 5. Switch between 0° and 90° positions with 90° rotation handle.

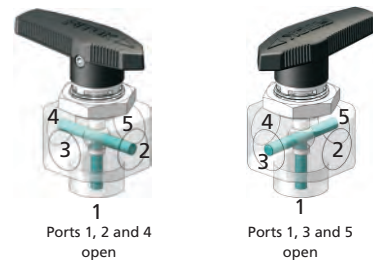

5LV Flow Path

This type of valve can connect two adjacent ports to the bottom port, and shut off other two side ports at the same time. Switching can be done in 90° increments with 360° rotation handle.

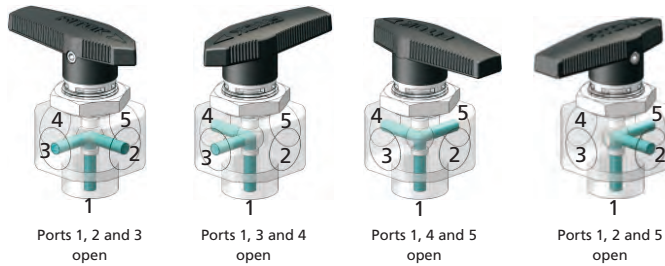

Note: For Temperature vs. Pressure curve and dimensions of 5-way valves, see Switching (5-way) Valves above.

Vent Port Options

Vented Valves

The maximum working pressure for vented valves is 500 psig (34.4 bar).

Straight-pattern Valves

A vent hole in the side of the valve body makes the downstream port vent to atmosphere when the valve is closed.

Angle-pattern and 3-way Valves

A vent hole in the side of the valve body makes the bottom port vent to atmosphere when the valve is closed.

Welded Vent Port Connections

A FITOK tube fitting or a tube stub welded to the vent port is available for stainless steel vented valves.

Bottom Screw Panel Mounting Options

Mounting Dimensions

The bottom screw panel mounting options are not available on angle-pattern valves, 3-way valves, 6-way valves and 7-way valves.

2-way

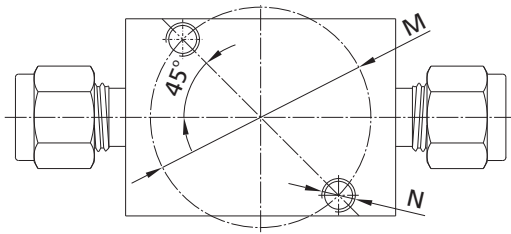

4-way

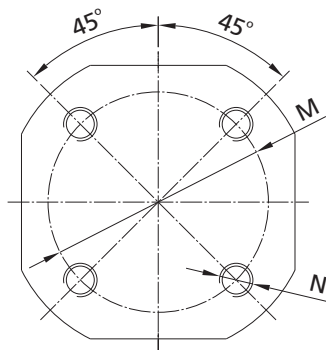

5-way

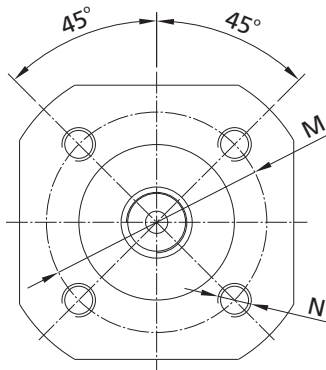

	Orifice in. (mm)	Dimensions, in. (mm)	
		M	N
2-way	0.05~0.13 (1.3~3.2)	0.63 (15.88)	M2.5 x 0.45 deep 0.24" (6)
	0.19 (4.8)	0.88 (22.23)	M3 x 0.5 deep 0.24" (6)
	0.28 (7.1)	1.25 (31.75)	M5 x 0.8 deep 0.24" (6)
4-way	0.41 (10.3)	1.63 (41.28)	M5 x 0.8 deep 0.24" (6)
	0.05~0.06 (1.3~1.6)	1.25 (31.75)	M5 x 0.8 deep 0.24" (6)
5-way	0.28 (7.1)	2.00 (50.8)	M5 x 0.8 deep 0.24" (6)
	0.05~0.06 (1.3~1.6)	1.25 (31.75)	M5 x 0.8 deep 0.24" (6)
5-way	0.41 (10.3)	2.00 (50.8)	M5 x 0.8 deep 0.24" (6)
	0.05~0.06 (1.3~1.6)	1.25 (31.75)	M5 x 0.8 deep 0.24" (6)

Ordering Number Description

BOSS - ML6 - FL4 - ML8 - H05 - OHQ3L - B - FL4 - SF2

Series	Body Material	Connection 1 Type	Connection 1 Size	Connection 2 to 7 Type	Connection 2 to 7 Size	Seat Material	Orifice Size	Handle/Actuator	For Actuator	Flow Pattern	Panel Installation	Vent Port	Special Application	Cleaning and Packaging
BO	SS 316 SS S4 304 SS S1 321 SS 6L 316L SS B Brass M Alloy 400	FNS Female NPT NS Male NPT FRT Female BSPT RT Male BSPT FMS Female Metric Thread (for RG-M) MS Male Metric Thread (for RG-M) FRP Female BSPP (for RP) FL Fractional Tube Fitting ML Metric Tube Fitting FO Male FO Fitting FR Male FR Fitting	1 1/16" 2 1/8" 3 3 mm 4 1/4" 6 3/8" or 6 mm 8 1/2" or 8 mm 10 10 mm 12 3/4" or 12 mm 14 14 mm 16 16 mm 18 18 mm	Same as connection 1 Specified in the same way as the connection 1 type and size	00 0.05" (1.3 mm) 01 0.06" (1.6 mm) 02 0.09" (2.4 mm) 03 0.13" (3.2 mm) 05 0.19" (4.8 mm) 07 0.28" (7.1 mm) 10 0.41" (10.3 mm)	Black Nylon Handle Red Nylon Handle Green Nylon Handle Blue Nylon Handle Black Aluminium Handle 90° Normally Closed Pneumatic Actuator 90° Normally Open Pneumatic Actuator 90° Double Acting Pneumatic Actuator 180° Left End Normally Open Pneumatic Actuator 180° Right End Normally Open Pneumatic Actuator 180° Double Acting Pneumatic Actuator 90° Electric Actuator 180° Electric Actuator	NO H Mechanical Limit Switch N Inductive Limit Switch Q Solenoid Valve HQ and Solenoid Valve NQ Inductive Limit Switch and Solenoid Valve	A 3L 3HL 4L 4C 4H 4HL 4V 5L 5H 5HL 5LV 6L 6C 7L	Straight Angle 3-way 4-way 5-way 6-way 7-way	No vent port FL2 1/8" tube fitting FL4 1/4" tube fitting FL6 3/8" tube fitting ML3 3 mm tube fitting ML6 6 mm tube fitting ML8 8 mm tube fitting Panel nut Bottom screw B	NO S NACE MR0175 SI SilcoNert® 2000 (Sulfinert®) Coating CE CE Certification	FC-01 F2 FC-02		

Note: "Ordering Number Description" is a reference to understand the combination rules of FITOK product part number. Not all combinations are available.

- For oxygen-enriched environment or hazardous media service, contact FITOK Group or our authorized distributors.
- Cleaning and Packaging:
FC-01: Standard cleaning and packaging for general industrial procedures.
FC-02: Special cleaning and packaging for wetted system components to ensure compliance with product cleanliness requirement of ASTM G93 Level C.
- For more information about pneumatic actuator ball valves, please refer to the catalog **Automatic Control Ball Valves**.
- SilcoNert® 2000 (Sulfinert®) Coating: Wetted metal components SilcoNert® 2000 (Sulfinert®) coated.
- CE certification is available. For more information, please contact FITOK group or our authorized distributors.

Bar Stock Ball Valves

BP Series

Features

- ⦿ Working pressure up to: 10000 psig (690 bar)
- ⦿ Working temperature: -40°F to 450°F (-40°C to 232°C)
- ⦿ Bidirectional flow for 2-way valves
- ⦿ Seat wear compensation by free floating ball
- ⦿ Variety of end connections
- ⦿ Blowout proof stem with self-sealing function
- ⦿ Handle color options available
- ⦿ Optional pneumatic and electric actuator
- ⦿ Leak-tight performance testing with nitrogen or compressed air for every valve at the rated pressure (not higher than 6000 psig) to meet the requirement of no visible leak
- ⦿ Restricted flow path for BP series: only port 1 as inlet, port 2 and port 3 as outlet



Pressure vs. Temperature

2-way Valves

Orifice code: 10

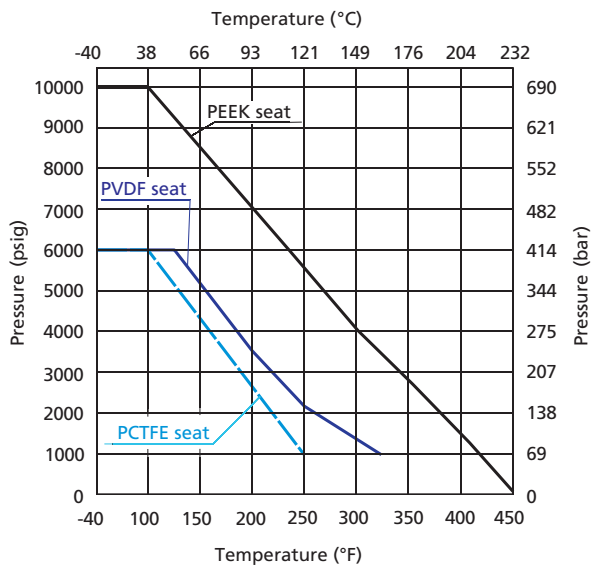

Orifice code: 13 and 19

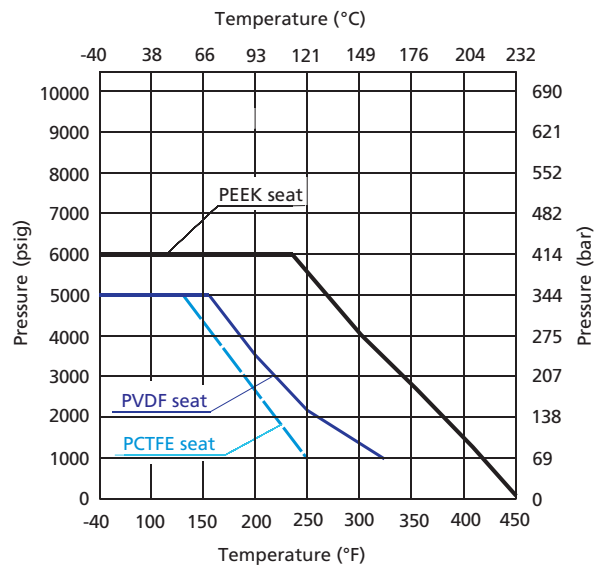

3-way Valves

Orifice code: 10

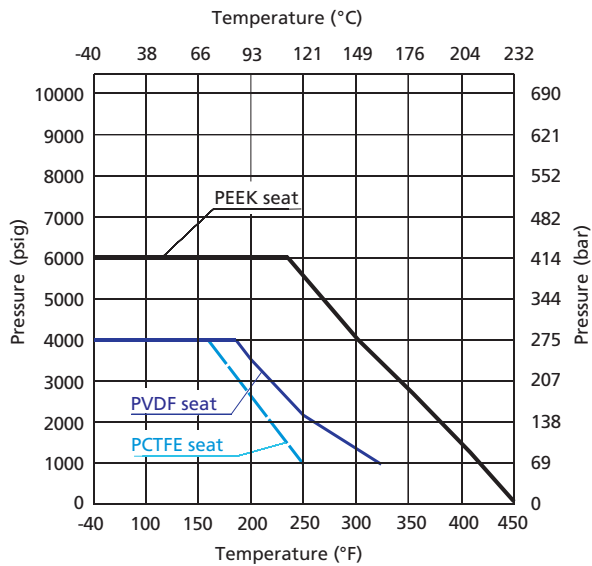

Orifice code: 13 and 19

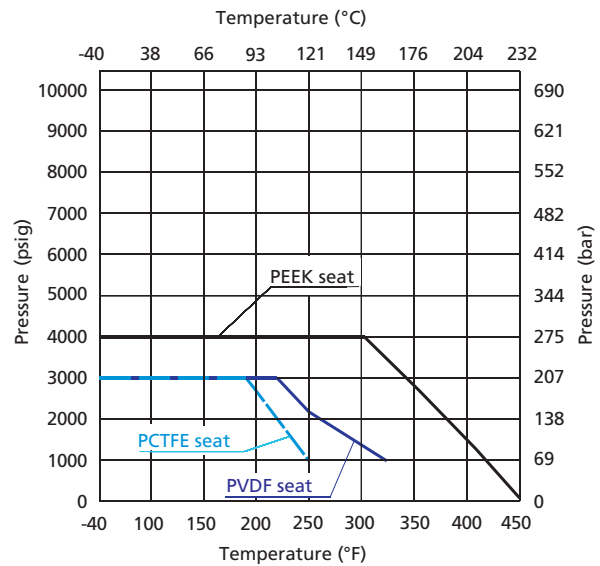

Note: 1. Graphs are with 316 SS body. For information of body in other materials, please contact FITOK Group or our authorized distributors.
 2. The working pressure of valves is restricted by materials of the valve body and seat, as well as end connections. When choosing a valve for your applications, please refer to the above Temperature vs. Pressure Curves and the pressure rating in the dimension table. The minimum value shall be the pressure rating of the valve.

Standard Materials of Construction

2-way Valves

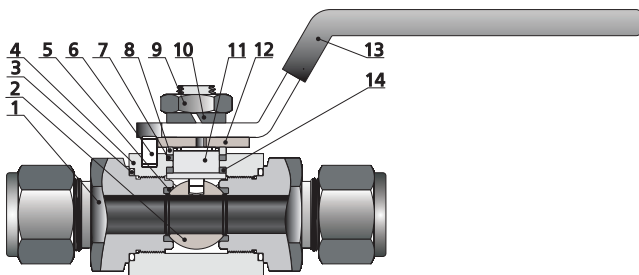

3-way Valves

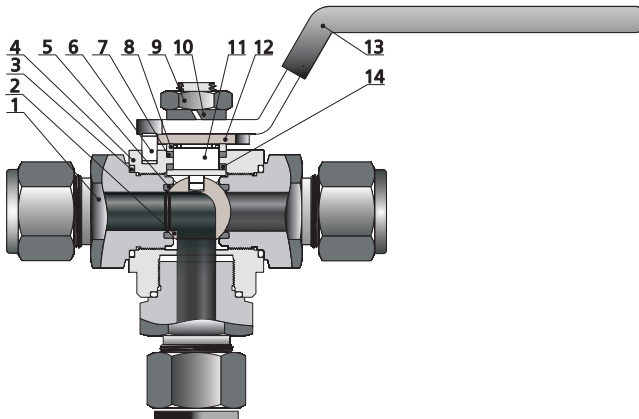

Item	Component	Body Material
		316 SS
1	<i>End Connection</i>	<i>316 SS/A479</i>
2	<i>Ball</i>	<i>316 SS/A479</i>
3	<i>O-ring</i>	<i>Fluorocarbon FKM</i>
4	<i>Body</i>	<i>316 SS/A479</i>
5	<i>Seat</i>	<i>PVDF or PCTFE or PEEK</i>
6	<i>Stop Pin</i>	SS
7	<i>Stem Packing</i>	<i>PTFE/D1710</i>
8	<i>Stem Washer</i>	316 SS/A479
9	<i>Stem Nut</i> ①	SS
10	<i>Spring Washer</i>	SS
11	<i>Stem</i>	<i>316 SS/A479</i>
12	<i>Stop Block</i>	304 SS/A240
13	<i>Handle</i>	SS with vinyl cover
14	<i>Lower Packing</i> ②	PEEK

Note: Wetted components are listed in italics.
 For other materials, please contact FITOK Group or our authorized distributors.

- ① Ball valves with orifice code 13 or 19 have 2 stem nuts.
- ② Lower packing material of ball valves with orifice code 19 is PTFE.

Ball Valves
Plug Valves

Dimensions

2-way Valves

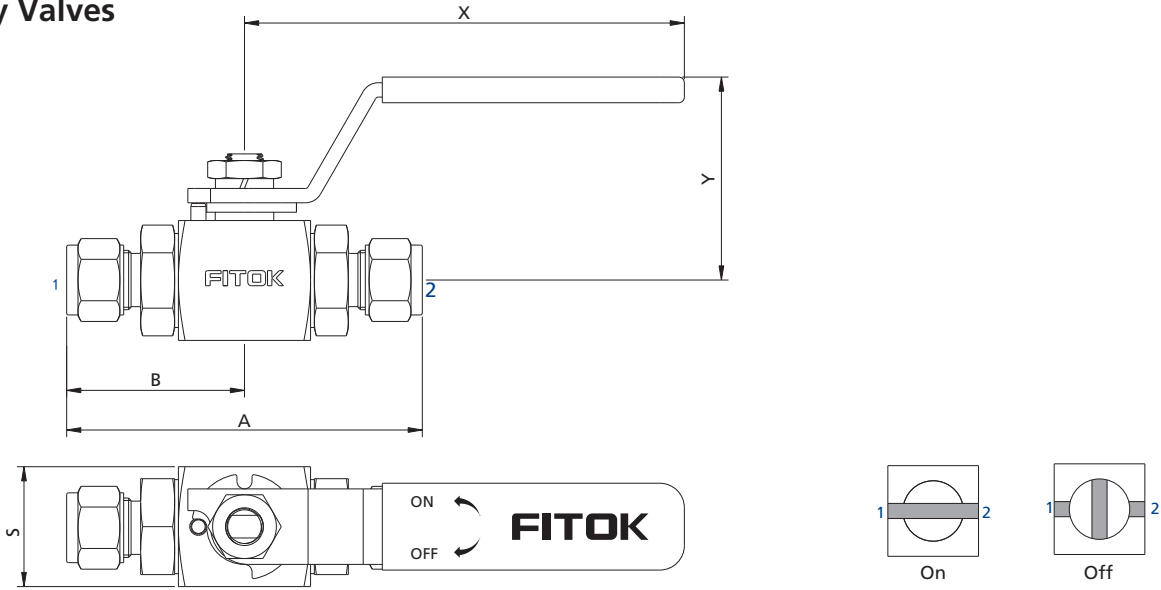

Ball Valves
Plug Valves

Basic Ordering Number	Connection Type and Size	Pressure Rating of End Connections @ 100°F (38°C), psig (bar)	Orifice in. (mm)	Cv	Dimensions, in. (mm)				
					A	B	X	Y	S
BP□□-ML6-10	6 mm FITOK	10000 (690)	0.19(4.8)	1.2	3.54 (90.0)	1.77 (45.0)	4.57 (116.0)	2.10 (53.4)	1.30 (32.0)
BP□□-ML8-10	8 mm FITOK	7500 (517)	0.25(6.4)	2.3	3.60 (91.6)	1.80 (45.8)			
BP□□-ML10-10	10 mm FITOK	8400 (579)	0.28(7.1)	3.7	3.70 (94.0)	1.85 (47.0)			
BP□□-ML12-10	12 mm FITOK	6800 (469)	0.39 (10.0)	7.5	3.94 (100.0)	1.97 (50.0)			
BP□□-ML14-10	14 mm FITOK	6200 (427)			3.92 (99.6)	1.96 (49.8)			
BP□□-FL4-10	1/4" FITOK	10000 (690)	0.19(4.8)	1.2	3.56 (90.4)	1.78 (45.2)			
BP□□-FL6-10	3/8" FITOK	6500 (448)	0.28(7.1)	3.7	3.72 (94.6)	1.86 (47.3)			
BP□□-FL8-10	1/2" FITOK	6700 (462)	0.39 (10.0)	7.5	3.03 (77.0)	1.52 (38.5)			
BP□□-FNS4-10	1/4 Female NPT	10000 (690)			2.80 (71.0)	1.40 (35.5)			
BP□□-FNS6-10	3/8 Female NPT	10000 (690)			3.27 (83.0)	1.63 (41.5)			
BP□□-FNS8-10	1/2 Female NPT	10000 (690)			3.36 (85.4)	1.68 (42.7)			
BP□□-NS4-10	1/4 Male NPT	10000 (690)	0.28(7.1)	3.7	3.75 (95.2)	1.88 (47.6)			
BP□□-NS6-10	3/8 Male NPT	10000 (690)	0.39 (10.0)	7.5					
BP□□-NS8-10	1/2 Male NPT	10000 (690)			4.12 (104.6)	2.06 (52.3)			
BP□□-ML16-13	16 mm FITOK	5800 (400)			0.50 (12.7)	10.0	4.43 (112.6)	2.22 (56.3)	
BP□□-ML18-13	18 mm FITOK	5400 (372)					4.29 (109.0)	2.15 (54.5)	
BP□□-ML20-13	20 mm FITOK	5500 (379)	4.36 (110.6)	2.18 (55.3)					
BP□□-ML22-13	22 mm FITOK	4900 (338)	3.54 (90.0)	1.77 (45.0)					
BP□□-FL10-13	5/8" FITOK	6000 (414)	4.09 (104.0)	2.05 (52.0)					
BP□□-FL12-13	3/4" FITOK	5800 (400)	4.14 (105.2)	2.07 (52.6)					
BP□□-FNS8-13	1/2 Female NPT	6000 (414)	0.71 (18.0)	30.0			4.87 (123.8)	2.43 (61.9)	
BP□□-FNS12-13	3/4 Female NPT	6000 (414)					5.11 (129.8)	2.66 (64.9)	
BP□□-NS12-13	3/4 Male NPT	6000 (414)					4.59 (116.6)	2.29 (58.3)	
BP□□-ML20-19	20 mm FITOK	5500 (379)					5.11 (129.8)	2.66 (64.9)	
BP□□-ML22-19	22 mm FITOK	4900 (338)			3.81 (96.8)	1.91 (48.4)			
BP□□-ML25-19	25 mm FITOK	4600 (317)			4.26 (108.2)	2.13 (54.1)			
BP□□-FL12-19	3/4" FITOK	5800 (400)			4.91 (124.8)	2.45 (62.4)			
BP□□-FL16-19	1" FITOK	4700 (324)							
BP□□-FNS12-19	3/4 Female NPT	6000 (414)							
BP□□-FNS16-19	1 Female NPT	6000 (414)							
BP□□-NS16-19	1 Male NPT	6000 (414)							

3-way Valves

Vertical Pattern

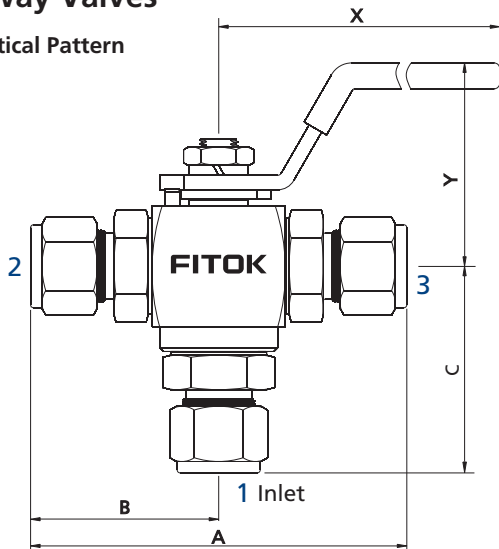

Port 1 as inlet
180° rotation handle

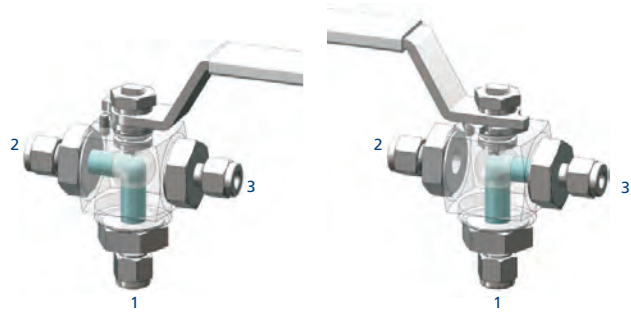

Port 1 to port 2

Port 1 to port 3

Horizontal Pattern

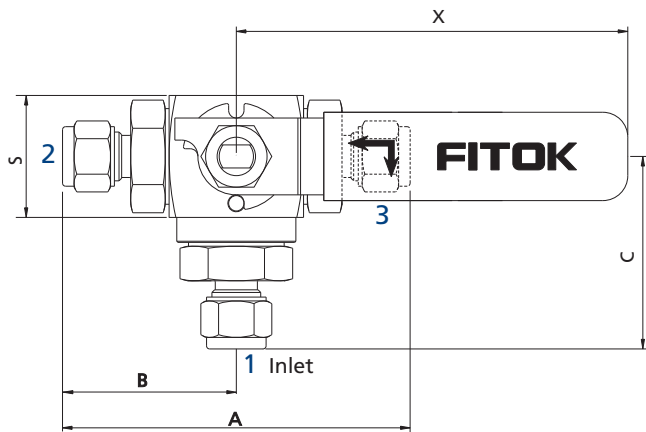

Port 1 as inlet
90° rotation handle

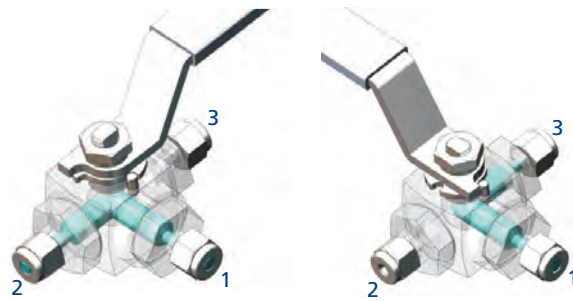

Port 1 to port 2

Port 1 to port 3

Basic Ordering Number	Connection Type and Size	Pressure Rating of End Connections @ 100 °F (38 °C), psig (bar)	Orifice in. (mm)	Dimensions, in. (mm)						
				A	B	C	X	Y	S	
BP□□-ML6-10-3□	6 mm FITOK	10000 (690)	0.19 (4.8)	3.54 (90.0)	1.77 (45.0)	2.00 (51.0)	4.57 (116.0)	2.10 (53.4)	1.30 (32.0)	
BP□□-ML8-10-3□	8 mm FITOK	7500 (517)	0.25 (6.4)	3.60 (91.6)	1.80 (45.8)	2.02 (51.3)				
BP□□-ML10-10-3□	10 mm FITOK	8400 (579)	0.28 (7.1)	3.70 (94.0)	1.85 (47.0)	2.07 (52.5)				
BP□□-ML12-10-3□	12 mm FITOK	6800 (469)	0.39 (10.0)	3.94 (100.0)	1.97 (50.0)	2.18 (55.5)				
BP□□-ML14-10-3□	14 mm FITOK	6200 (427)		3.94 (100.0)	1.97 (50.0)	2.18 (55.5)				
BP□□-FL4-10-3□	1/4" FITOK	10000 (690)	0.19 (4.8)	3.56 (90.4)	1.78 (45.2)	1.95 (49.5)				
BP□□-FL6-10-3□	3/8" FITOK	6500 (448)	0.28 (7.1)	3.72 (94.6)	1.86 (47.3)	2.16 (54.8)				
BP□□-FL8-10-3□	1/2" FITOK	6700 (462)	0.39 (10.0)	3.92 (99.6)	1.96 (49.8)	2.13 (54.0)				
BP□□-FNS4-10-3□	1/4 Female NPT	10000 (690)		3.03 (77.0)	1.52 (38.5)	1.44 (36.5)				
BP□□-FNS6-10-3□	3/8 Female NPT	10000 (690)		2.80 (71.0)	1.40 (35.5)	1.57 (40.0)				
BP□□-FNS8-10-3□	1/2 Female NPT	10000 (690)		3.27 (83.0)	1.63 (41.5)	1.83 (46.4)				
BP□□-NS4-10-3□	1/4 Male NPT	10000 (690)		0.28 (7.1)	3.36 (85.4)	1.68 (42.7)				1.90 (48.2)
BP□□-NS6-10-3□	3/8 Male NPT	10000 (690)			0.39 (10.0)	3.36 (85.4)				1.68 (42.7)
BP□□-NS8-10-3□	1/2 Male NPT	10000 (690)	3.75 (95.2)			1.88 (47.6)				2.09 (53.1)

Ball Valves
Plug Valves

Basic Ordering Number	Connection Type and Size	Pressure Rating of End Connections @ 100°F (38°C), psig (bar)	Orifice in. (mm)	Dimensions, in. (mm)					
	Connection 1/2/3			316 SS	A	B	C	X	Y
BP□□-ML16-13-3□	16 mm FITOK	5800 (400)	0.50 (12.7)	4.42 (112.2)	2.21 (56.1)	2.60 (66.1)	5.59 (142.0)	2.54 (64.4)	1.50 (38.0)
BP□□-ML18-13-3□	18 mm FITOK	5400 (372)		4.12 (104.6)	2.06 (52.3)	2.45 (62.3)			
BP□□-ML20-13-3□	20 mm FITOK	5500 (379)		4.43 (112.6)	2.22 (56.3)	2.61 (66.3)			
BP□□-ML22-13-3□	22 mm FITOK	4900 (338)		4.29 (109.0)	2.15 (54.5)	2.54 (64.5)			
BP□□-FL10-13-3□	5/8" FITOK	6000 (414)		4.36 (110.6)	2.18 (55.3)	2.57 (65.3)			
BP□□-FL12-13-3□	3/4" FITOK	5800 (400)		3.54 (90.0)	1.77 (45.0)	2.02 (51.2)			
BP□□-FNS8-13-3□	1/2 Female NPT	6000 (414)		4.09 (104.0)	2.05 (52.0)	2.44 (62.0)			
BP□□-FNS12-13-3□	3/4 Female NPT	6000 (414)		4.14 (105.2)	2.07 (52.6)	2.46 (62.6)			
BP□□-NS12-13-3□	3/4 Male NPT	6000 (414)							
BP□□-ML20-19-3□	20 mm FITOK	5500 (379)	0.71 (18.0)	4.87 (123.8)	2.43 (61.9)	2.89 (73.4)	6.46 (164.0)	2.72 (69.0)	1.96 (50.0)
BP□□-ML22-19-3□	22 mm FITOK	4900 (338)		5.11 (129.8)	2.66 (64.9)	3.00 (76.2)			
BP□□-ML25-19-3□	25 mm FITOK	4600 (317)		4.86 (123.4)	2.43 (61.7)	3.02 (76.7)			
BP□□-FL12-19-3□	3/4" FITOK	5800 (400)		5.11 (129.8)	2.66 (64.9)	2.85 (72.4)			
BP□□-FL16-19-3□	1" FITOK	4700 (324)		3.82 (97.0)	1.91 (48.5)	2.22 (56.5)			
BP□□-FNS12-19-3□	3/4 Female NPT	6000 (414)		4.26 (108.2)	2.13 (54.1)	2.72 (69.1)			
BP□□-FNS16-19-3□	1 Female NPT	6000 (414)		4.54 (115.2)	2.27 (57.6)	2.72 (69.1)			
BP□□-NS12-19-3□	3/4 Male NPT	6000 (414)		4.91 (124.8)	2.45 (62.4)	2.90 (73.9)			
BP□□-NS16-19-3□	1 Male NPT	6000 (414)							

1. FITOK means FITOK double ferrule tube fittings.
2. Sizes and types listed are standard. Other sizes and types are available upon request, please contact FITOK Group or our authorized distributors.
3. Dimensions are shown with tube fitting nuts finger-tightened. All dimensions are for reference only and are subject to change. For dimensions not shown above, please contact FITOK Group or our authorized distributors.

Panel Mounting Options

Dimension for Panel Mounting

Orifice in. (mm)	in. (mm)			
	L1	L2	T1	T2
0.39 (10.0)	1.02 (26.0)	1.02 (26.0)	M4 × 0.7P deep 0.19 (5.0)	1.18 (30.0)
0.50 (12.7)	1.18 (30.0)	1.18 (30.0)	M5 × 0.8P deep 0.19 (5.0)	1.18 (30.0)
0.71 (18.0)	1.37 (35.0)	1.57 (40.0)	M5 × 0.8P deep 0.19 (5.0)	1.50 (38.0)

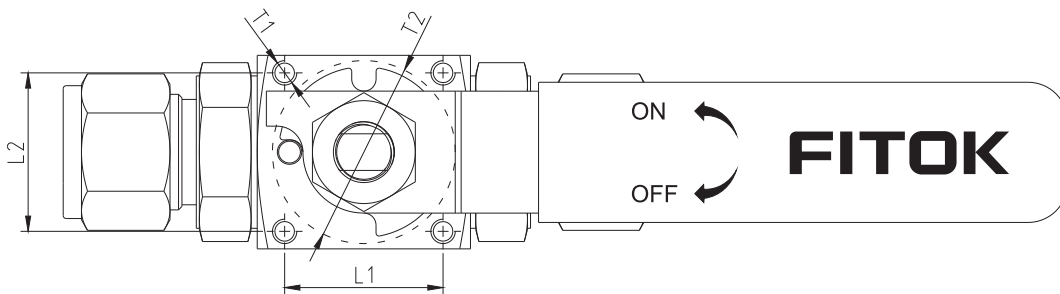

Ordering Number Description

BPSS - ML20 - FL12 - FNS8 - P13 - OHQ3ML - SCEF2

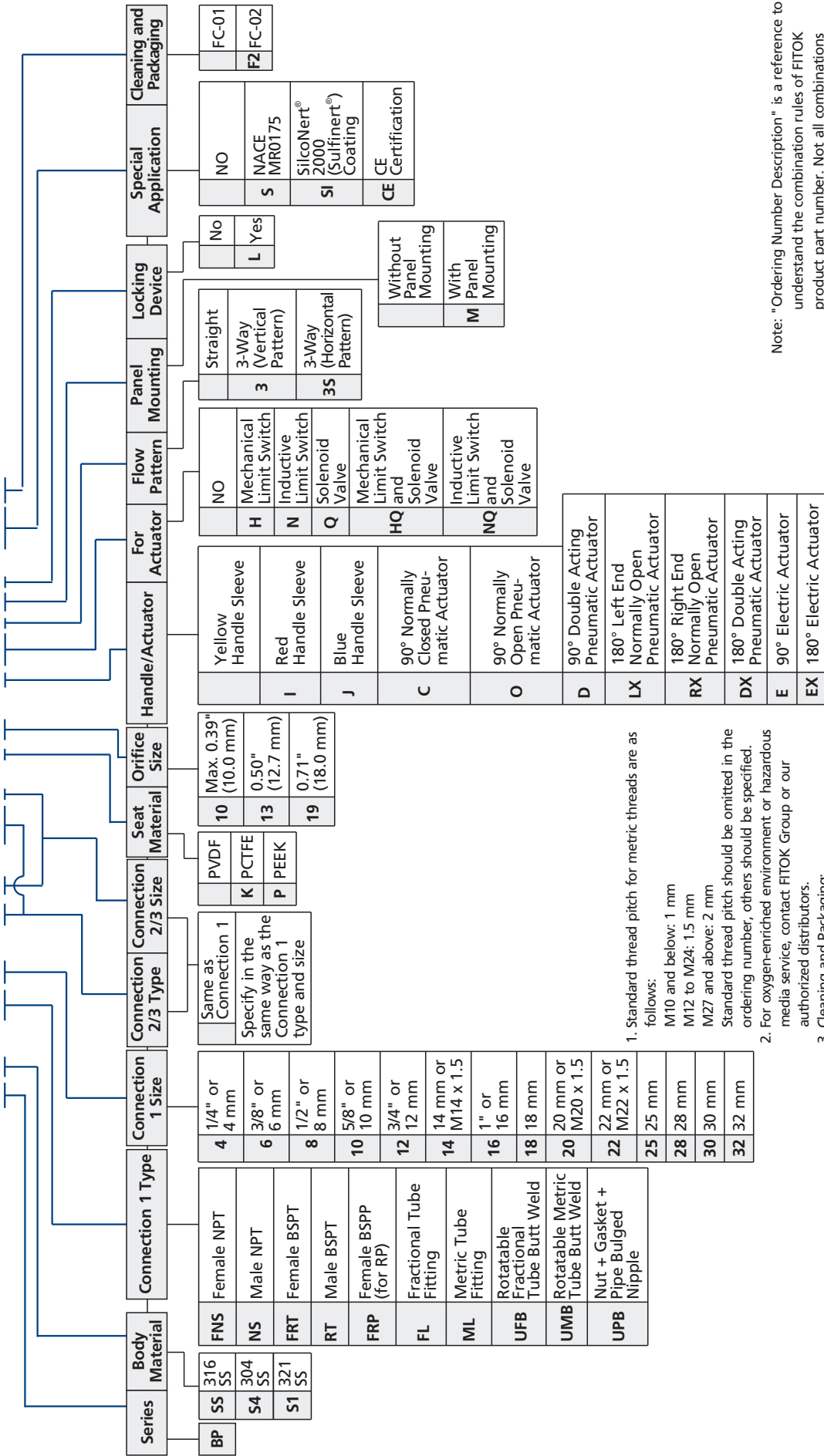

- Standard thread pitch for metric threads are as follows:
 M10 and below: 1 mm
 M12 to M24: 1.5 mm
 M27 and above: 2 mm
 Standard thread pitch should be omitted in the ordering number, others should be specified.
- For oxygen-enriched environment or hazardous media service, contact FITOK Group or our authorized distributors.
- Cleaning and Packaging:
 FC-01: Standard cleaning and packaging for wetted system components to ensure compliance with product cleanliness requirements of ASTM G93 Level C
 FC-02: Special cleaning and packaging for wetted system components to ensure compliance with product cleanliness requirements of ASTM G93 Level C

Note: "Ordering Number Description" is a reference to understand the combination rules of FITOK product part number. Not all combinations are available.

- For more information about pneumatic actuator ball valves, please refer to the catalog **Automatic Control Ball Valves**.
- SulcoNert® 2000 (Sulfinert®) Coating: Except for ball valves with PEEK seat, wetted metal components SulcoNert® 2000 (Sulfinert®) coated.
- CE certification is available. For more information, please contact FITOK group or our authorized distributors.

Hex Bar Stock Ball Valves

BR and BRC Series

Features

- ⦿ Working pressure up to:
 - BR Series: 1000 psig (69.0 bar)
 - BRC Series: 2000 psig (138 bar)
- ⦿ Working temperature:
 - BR Series: -20°F to 450°F (-28°C to 232°C)
 - BRC Series: -65°F to 400°F (-54°C to 204°C)
- ⦿ Compact and economical design
- ⦿ Free floating ball design for seat wear compensation
- ⦿ Bi-directional flow
- ⦿ Low operating torque
- ⦿ A variety of end connections available
- ⦿ Blowout proof stem
- ⦿ Handle color options available
- ⦿ Leak-tight performance testing with nitrogen or compressed air for every valve at the rated pressure to meet the requirement of no visible leak



Pressure vs. Temperature

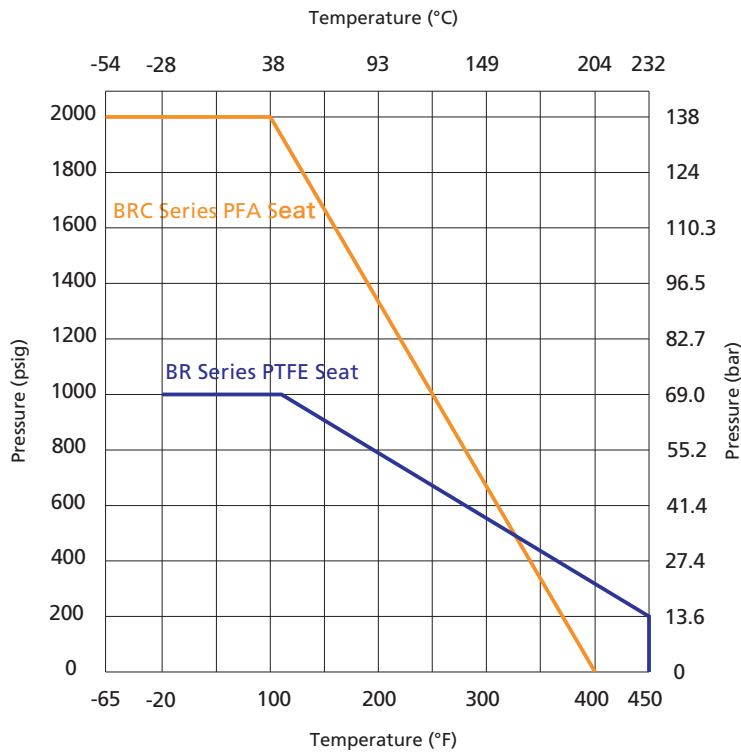

Standard Materials of Construction

BR Series

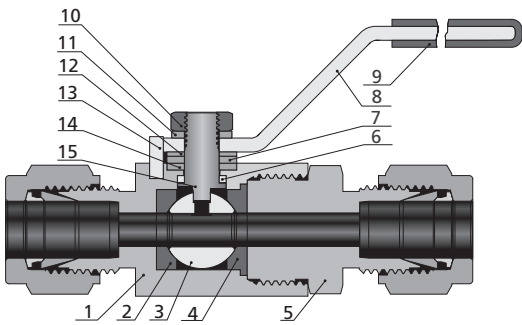

BRC Series

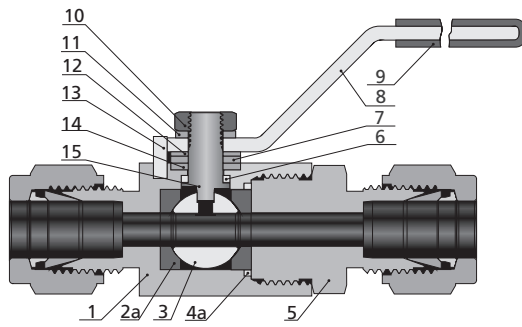

Item	Component	BR Series		BRC Series
		Valve Body Material		
		316 SS	Brass	316 SS
Material Grade/ASTM Specification				
1	<i>Body</i>	<i>316 SS/A479</i>	<i>Brass C36000/B16</i>	<i>316 SS/A479</i>
2	<i>Front Seat</i>	<i>PTFE/D1710</i>		
2a	<i>Seat</i>	—		<i>PFA/D3307</i>
3	<i>Ball</i>	<i>316 SS/A479</i>		
4	<i>Back Seat</i>	<i>PTFE/D1710</i>		
4a	<i>Sealing Gasket</i>	—		<i>316L SS/A269</i>
5	<i>End Connection</i>	<i>316 SS/A479</i>	<i>Brass C36000/B16</i>	<i>316 SS/A479</i>
6	<i>Lower Packing</i>	<i>PTFE/D1710</i>		
7	<i>Washer</i>	<i>316 SS/A479</i>		
8	<i>Handle</i>	<i>304 SS/A240 or Aluminium</i>		
9	<i>Sleeve</i>	<i>Vinyl</i>		
10	<i>Stem Nut</i>	<i>SS</i>		
11	<i>Gasket</i>	<i>SS</i>		
12	<i>Coned-disc Spring</i>	<i>S17700/A693</i>		
13	<i>Stop Pin</i>	<i>SS</i>		
14	<i>Upper Packing</i>	<i>PTFE/D1710</i>		
15	<i>Stem</i>	<i>316 SS/A479</i>		

Note: Wetted components are listed in italics.

For other materials, please contact FITOK Group or our authorized distributors.

Dimensions

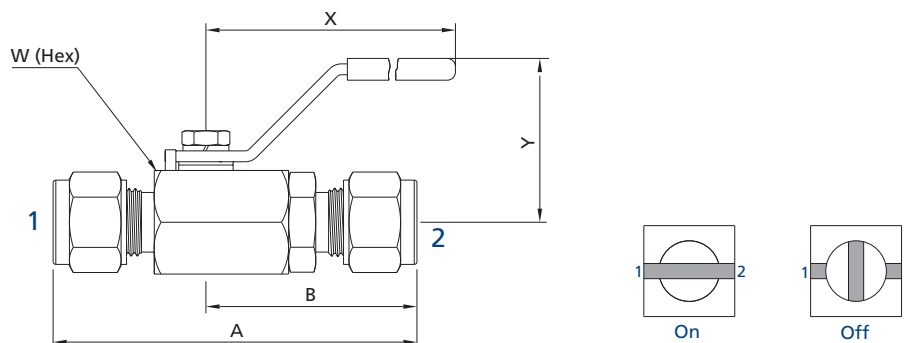

B-44 Ball Valves

Basic Ordering Number		Connection Type and Size	Orifice in. (mm)	Cv	Dimensions, in. (mm)				
					Connection 1/2	A	B	W	X
BR□□-ML6-05	BRC□□-ML6-05	6 mm FITOK	0.19 (4.8)	1.25	2.57 (65.2)	1.50 (38.1)	3/4 (19.05)	2.36 (60)	1.18 (30)
BR□□-ML8-05	BRC□□-ML8-05	8 mm FITOK			2.63 (66.8)	1.53 (38.8)			
BR□□-FL4-05	BRC□□-FL4-05	1/4" FITOK			2.57 (65.2)	1.50 (38.1)			
BR□□-FL5-05	BRC□□-FL5-05	5/16" FITOK			2.63 (66.8)	1.53 (38.8)			
BR□□-FNS2-05	BRC□□-FNS2-05	1/8 Female NPT			1.85 (47.0)	1.08 (27.4)			
BR□□-FRP2-05	BRC□□-FRP2-05	1/8 Female BSPP			2.00 (50.0)	1.14 (29.0)			
BR□□-FRP4-05	BRC□□-FRP4-05	1/4 Female BSPP			2.00 (50.0)	1.14 (29.0)			
BR□□-FNS4-05	BRC□□-FNS4-05	1/4 Female NPT			1.85 (47.0)	1.08 (27.4)			
BR□□-ML10-07	BRC□□-ML10-07	10 mm FITOK			0.28 (7.1)	2.50			
BR□□-FL6-07	BRC□□-FL6-07	3/8" FITOK	2.03 (51.6)	1.18 (30.0)					
BR□□-FRP6-07	BRC□□-FRP6-07	3/8 Female BSPP							
BR□□-FNS6-07	BRC□□-FNS6-07	3/8 Female NPT							
BR□□-ML12-10	BRC□□-ML12-10	12 mm FITOK	0.35 (8.9)	9.25	3.15 (80.0)	1.83 (46.5)	1 1/16 (27.0)	3.15 (80)	1.54 (39)
BR□□-ML14-10	BRC□□-ML14-10	14 mm FITOK			3.24 (82.2)	1.87 (47.5)			
BR□□-FL8-10	BRC□□-FL8-10	1/2" FITOK			3.15 (80.0)	1.83 (46.5)			
BR□□-FL10-10	BRC□□-FL10-10	5/8" FITOK			3.24 (82.2)	1.87 (47.5)	15/16 (24.0)		
BR□□-FRP8-10	BRC□□-FRP8-10	1/2 Female BSPP			2.08 (53.0)	1.12 (28.5)			
BR□□-FNS8-10	BRC□□-FNS8-10	1/2 Female NPT			2.08 (53.0)	1.12 (28.5)			
BR□□-ML16-13	BRC□□-ML16-13	16 mm FITOK	0.47 (12.0)	12.65	3.50 (88.9)	2.00 (50.8)	1 1/4 (31.75)	3.94 (100)	2.03 (51.7)
BR□□-ML18-13	BRC□□-ML18-13	18 mm FITOK			2.48 (63.0)	1.30 (33.0)			
BR□□-FL12-13	BRC□□-FL12-13	3/4" FITOK							
BR□□-FRP12-13	BRC□□-FRP12-13	3/4 Female BSPP			2.39 (60.7)	1.20 (30.5)			
BR□□-FNS12-13	BRC□□-FNS12-13	3/4 Female NPT							
BR□□-ML22-16	BRC□□-ML22-16	22 mm FITOK	0.63 (16.0)	17.35	3.96 (100.6)	2.24 (57.1)	1 1/2 (38.1)	2.15 (54.8)	
BR□□-ML25-16	BRC□□-ML25-16	25 mm FITOK			4.31 (109.5)	2.42 (61.5)			
BR□□-FL16-16	BRC□□-FL16-16	1" FITOK			3.25 (82.6)	1.63 (41.3)			
BR□□-FRP16-16	BRC□□-FRP16-16	1 Female BSPP			3.00 (76.5)	1.50 (38.1)			
BR□□-FNS16-16	BRC□□-FNS16-16	1 Female NPT							

1. FITOK means FITOK double ferrule tube fittings.

2. Sizes and types listed are standard. Other sizes and types are available upon request, please contact FITOK Group or our authorized distributors.

3. Dimensions are shown with tube fitting nuts finger-tightened. All dimensions are for reference only and are subject to change. For dimensions not shown above, please contact FITOK Group or our authorized distributors.

Ordering Number Description

BRSS – ML8 – FL4 – 05 – UL – SF2

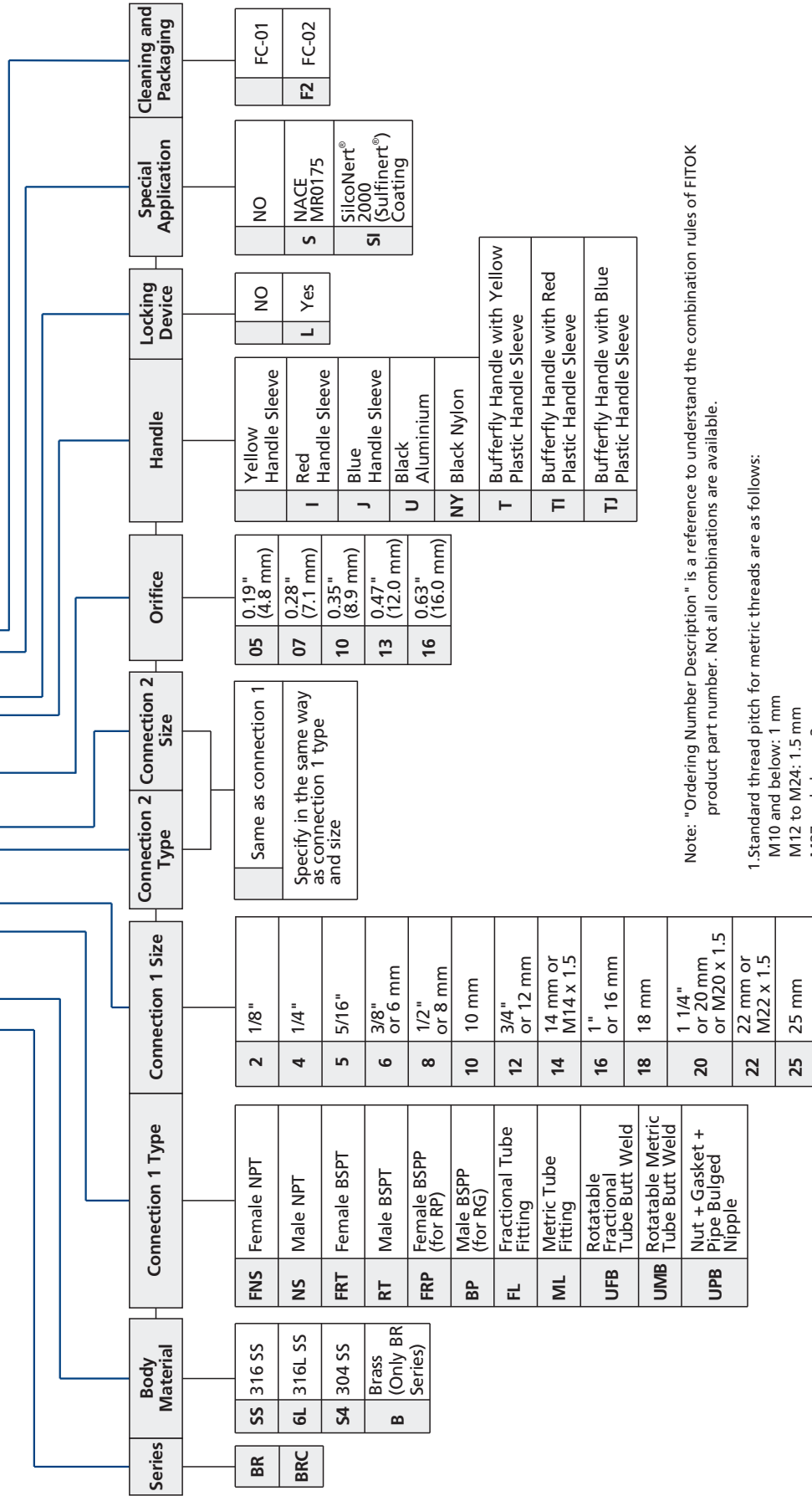

Note: "Ordering Number Description" is a reference to understand the combination rules of FITOK product part number. Not all combinations are available.

1. Standard thread pitch for metric threads are as follows:

M10 and below: 1 mm

M12 to M24: 1.5 mm

M27 and above: 2 mm

Standard thread pitch should be omitted in the ordering number, others should be specified.

2. For oxygen-enriched environment or hazardous media service, contact FITOK Group or our authorized distributors.

3. Cleaning and Packaging:

FC-01: Standard cleaning and packaging for general industrial procedures.

FC-02: Special cleaning and packaging for wetted system components to ensure compliance

with product cleaning requirement of ASTM G93 Level C.

4. SilcoNert® 2000 (Sulfinert®) Coating: Wetted metal components SilcoNert® 2000 (Sulfinert®) coated.

High Performance Ball Valves

BV Series

Features

- ⦿ Working pressure up to: 6000 psig (414 bar)
- ⦿ Working temperature: -65°F to 450°F (-54°C to 232°C)
- ⦿ Low operating torque
- ⦿ Handle as indicator of flow direction
- ⦿ Positive handle stop
- ⦿ Electric and pneumatic actuator available
- ⦿ Handle color options available
- ⦿ Leak-tight performance testing with nitrogen or compressed air for every valve to meet the requirement of no visible leakage at the rated pressure
- ⦿ Bi-directional flow for straight valves
- ⦿ The inlet of 3-way valves and angle pattern valves can only be the bottom port



Pressure vs. Temperature

316 SS Body

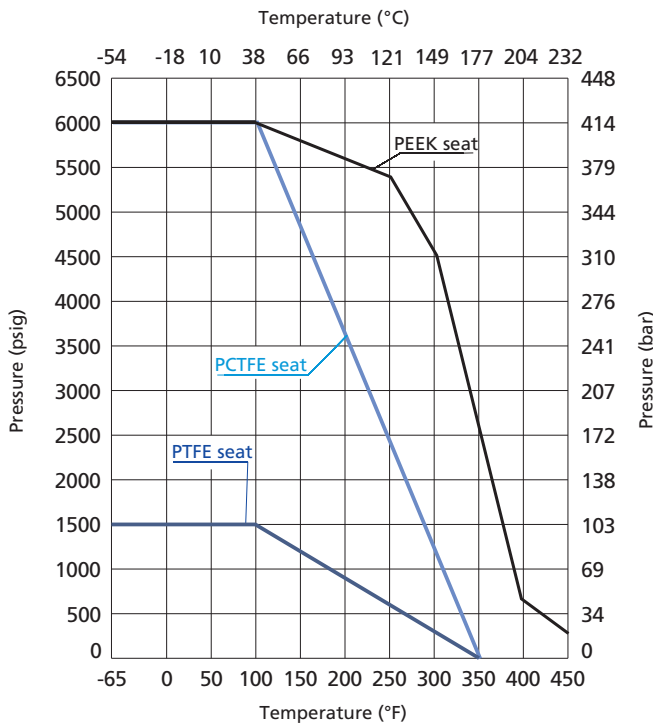

Brass Body

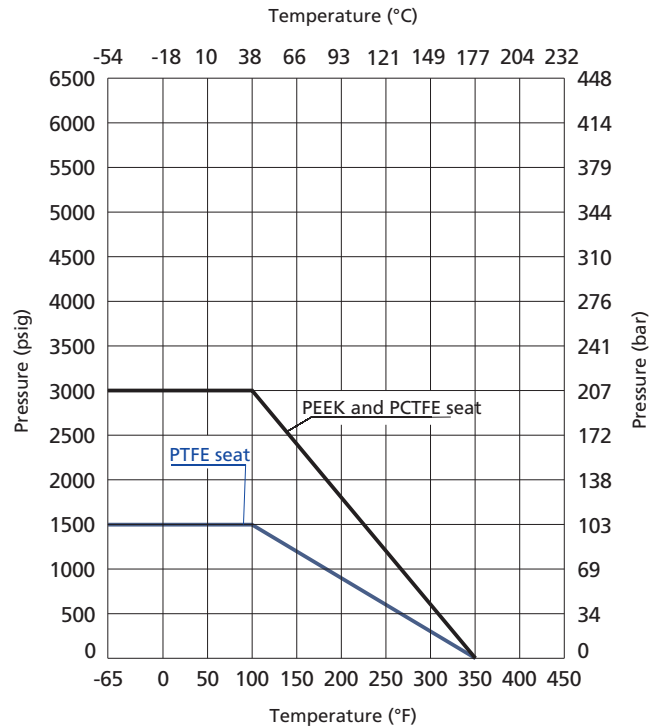

Note: The working pressure of valves is restricted by materials of the valve body and seat, as well as end connections. When choosing a valve for your applications, please refer to the above Temperature vs. Pressure Curves and the pressure rating in the dimension table. The minimum value shall be the pressure rating of the valve.

Standard Materials of Construction

Straight Valves

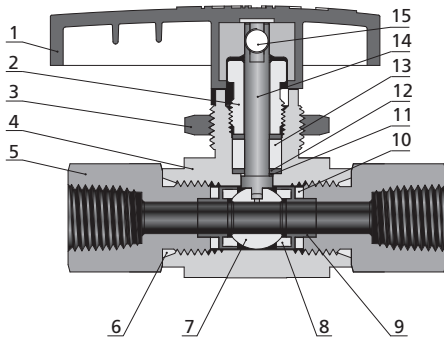

Item	Component	Valve Body Material	
		SS	Brass
1	Handle	Nylon or Aluminium	
2	Packing Nut	316 SS/A479	C36000/B16
3	Panel Nut	316 SS/A479	
4	<i>Body</i>	<i>CF8M/A351</i>	<i>C37700/B283</i>
5	<i>End Connection</i>	<i>316 SS/A479</i>	<i>C36000/B16</i>
6	<i>Connection O-ring</i>	PTFE	
7	<i>Ball</i>	<i>316 SS/A479</i>	
8	<i>Seat</i>	<i>PTFE or PCTFE or PEEK</i>	
9	<i>Seat Retainer</i>	<i>316 SS/A479</i>	
10	<i>Seat Packing</i>	PTFE	
11	<i>Stem Back-up Ring</i>	PEEK	
12	<i>Stem Washer</i>	<i>316/A479</i>	
13	<i>Stem Packing</i>	PTFE	
14	<i>Stem</i>	<i>316 SS/A479</i>	
15	Set Screw	Galvanized carbon steel	
	<i>Lubricants</i>	<i>Fluorinated-based</i>	

Note: Wetted components are listed in italics.

For other materials, please contact FITOK Group or our authorized distributors.

3-way Valves

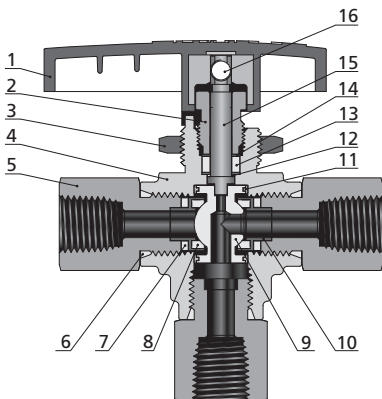

Item	Component	Valve Body Material	
		SS	Brass
1	Handle	Nylon or Aluminium	
2	Packing Nut	316 SS/A479	C36000/B16
3	Panel Nut	316 SS/A479	
4	<i>Body</i>	<i>CF8M/A351</i>	<i>C37700/B283</i>
5	<i>End Connection</i>	<i>316 SS/A479</i>	<i>C36000/B16</i>
6	<i>Connection O-ring</i>	PTFE	
7	<i>Seat Packing</i>	PTFE	
8	<i>Seat</i>	<i>PTFE or PCTFE or PEEK</i>	
9	<i>Ball</i>	<i>316 SS/A479</i>	
10	<i>Seat Retainer</i>	<i>316 SS/A479</i>	
11	<i>Trunnion Bearing</i>	PEEK	
12	<i>Stem Back-up Ring</i>	PEEK	
13	<i>Stem Packing</i>	PTFE	
14	<i>Stem Washer</i>	<i>316 SS/A479</i>	
15	<i>Stem</i>	<i>316 SS/A479</i>	
16	Set Screw	Galvanized carbon steel	
	<i>Lubricants</i>	<i>Fluorinated-based</i>	

Note: Wetted components are listed in italics.

For other materials, please contact FITOK Group or our authorized distributors.

Angle Pattern Valves

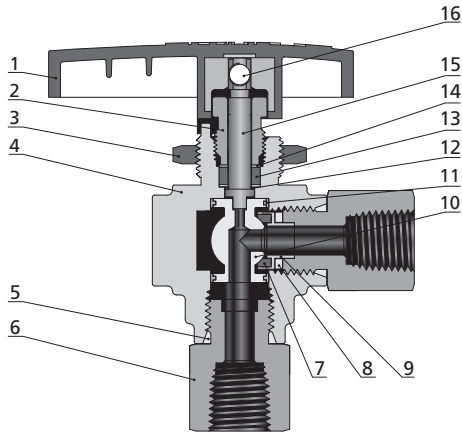

Item	Component	Valve Body Material	
		SS	Brass
1	Handle	Nylon or Aluminium	
2	Packing Nut	316 SS/A479	C36000/B16
3	Panel Nut	316 SS/A479	
4	Body	CF8M/A351	C37700/B283
5	Connection O-ring	PTFE	
6	End Connection	316 SS/A479	C36000/B16
7	Seat	PTFE or PCTFE or PEEK	
8	Seat Packing	PTFE	
9	Seat Retainer	316 SS/A479	
10	Ball	316 SS/A479	
11	Trunnion Bearing	PEEK	
12	Stem Back-up Ring	PEEK	
13	Stem Packing	PTFE	
14	Stem Washer	316 SS/A479	
15	Stem	316 SS/A479	
16	Set Screw	Galvanized carbon Steel	
	Lubricants	Fluorinated-based	

Note: Wetted components are listed in italics.
For other materials, please contact FITOK Group or our authorized distributors.

Dimensions

Straight Valves

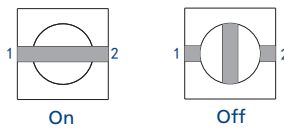
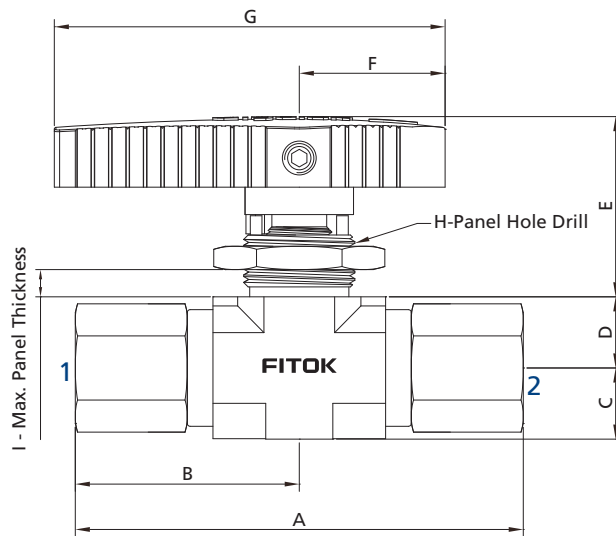

Basic Ordering Number	Connection Type and Size	Pressure Rating of End Connections @ 100°F (38°C)		Orifice in. (mm)	Cv	Dimensions, in. (mm)																					
		316 SS	Brass			A	B	C	D	E	F	G	H	I													
BV□□-FL1-01	1/16" FITOK	6000 (414)	3000 (207)	0.05 (1.3)	0.06	2.60 (66.0)	1.30 (33.0)																				
BV□□-FL2-02	1/8" FITOK	6000 (414)	3000 (207)	0.09 (2.4)	0.21	2.72 (69.0)	1.36 (34.5)																				
BV□□-ML3-02	3 mm FITOK	6000 (414)	3000 (207)			2.74 (69.6)	1.37 (34.8)																				
BV□□-FRT2-04	1/8 Female BSPT	6000 (414)	3000 (207)	0.17 (4.2)	0.93	2.14 (54.4)	1.07 (27.2)	0.36 (9.2)	0.33 (8.5)	0.94 (23.9)	0.79 (20.0)	1.97 (50.0)	0.58 (14.7)	0.18 (4.6)													
BV□□-FRP2-04	1/8 Female BSPP	6000 (414)	3000 (207)																								
BV□□-FNS2-04	1/8 Female NPT	6000 (414)	3000 (207)																								
BV□□-RT2-04	1/8 Male BSPT	6000 (414)	3000 (207)																								
BV□□-BP2-04	1/8 Male BSPP	6000 (414)	3000 (207)												2.36 (60.0)	1.18 (30.0)											
BV□□-NS2-04	1/8 Male NPT	6000 (414)	3000 (207)																								
BV□□-RT4-04	1/4 Male BSPT	6000 (414)	3000 (207)																								
BV□□-BP4-04	1/4 Male BSPP	6000 (414)	3000 (207)												2.70 (68.6)	1.35 (34.3)											
BV□□-NS4-04	1/4 Male NPT	6000 (414)	3000 (207)																								
BV□□-FL4-05	1/4" FITOK	6000 (414)	3000 (207)			0.19 (4.7)	1.04								3.48 (88.4)	1.74 (44.2)											
BV□□-ML6-05	6 mm FITOK	6000 (414)	3000 (207)												3.50 (89.0)	1.75 (44.5)											
BV□□-FL6-06	3/8" FITOK	6000 (414)	2200 (152)	0.25 (6.4)	2.34	3.60 (91.4)	1.80 (45.7)	0.48 (12.2)	0.48 (12.2)	1.24 (31.5)	0.59 (25.0)	2.64 (67.0)	0.77 (19.6)	0.25 (6.4)													
BV□□-ML8-06	8 mm FITOK	6000 (414)	2300 (159)			3.56 (90.4)	1.78 (45.2)																				
BV□□-ML10-06	10 mm FITOK	6000 (414)	1900 (131)			3.62 (92.0)	1.81 (46.0)																				
BV□□-FRT4-06	1/4 Female BSPT	6000 (414)	3000 (207)																								
BV□□-FRP4-06	1/4 Female BSPP	6000 (414)	3000 (207)												3.02 (76.8)	1.51 (38.4)											
BV□□-FNS4-06	1/4 Female NPT	6000 (414)	3000 (207)																								
BV□□-RT4-06	1/4 Male BSPT	6000 (414)	3000 (207)																								
BV□□-BP4-06	1/4 Male BSPP	6000 (414)	3000 (207)																								
BV□□-NS4-06	1/4 Male NPT	6000 (414)	3000 (207)																								
BV□□-RT6-06	3/8 Male BSPT	6000 (414)	3000 (207)																								
BV□□-BP6-06	3/8 Male BSPP	6000 (414)	3000 (207)																								
BV□□-NS6-06	3/8 Male NPT	6000 (414)	3000 (207)																								
BV□□-FL8-10	1/2" FITOK	6000 (414)	2100 (145)	0.41 (10.3)	6.42	4.68 (118.8)	2.34 (59.4)																				
BV□□-FL12-10	3/4" FITOK	5800 (400)	1800 (124)																								
BV□□-ML12-10	12 mm FITOK	6000 (414)	2000 (138)	0.37 (9.5)	5.57																						
BV□□-ML14-10	14 mm FITOK	6000 (414)	1900 (131)	0.41 (10.3)	6.42	4.66 (118.4)	2.33 (59.2)	0.75 (19.0)	0.71 (18.0)	1.54 (39.0)	1.42 (36.0)	3.78 (96.0)	0.90 (22.9)	0.38 (9.7)													
BV□□-ML16-10	16 mm FITOK	5800 (400)	1700 (117)																								
BV□□-ML18-10	18 mm FITOK	5400 (372)	1600 (110)																								
BV□□-ML20-10	20 mm FITOK	5500 (379)	1600 (110)																								
BV□□-ML22-10	22 mm FITOK	4900 (338)	1450 (100)												4.84 (123.0)	2.42 (61.5)											
BV□□-FRT6-10	3/8 Female BSPT	6000 (414)	3000 (207)																								
BV□□-FRP6-10	3/8 Female BSPP	6000 (414)	3000 (207)												3.90 (99.0)	1.95 (49.5)											
BV□□-FNS6-10	3/8 Female NPT	6000 (414)	3000 (207)																								
BV□□-FRT8-10	1/2 Female BSPT	6000 (414)	3000 (207)												4.30 (109.2)	2.15 (54.6)											
BV□□-FRP8-10	1/2 Female BSPP	6000 (414)	3000 (207)												3.97 (101.0)	1.99 (50.5)											
BV□□-FNS8-10	1/2 Female NPT	6000 (414)	3000 (207)												4.30 (109.2)	2.15 (54.6)											
BV□□-FRT12-10	3/4 Female BSPT	6000 (414)	3000 (207)																								
BV□□-FRP12-10	3/4 Female BSPP	6000 (414)	3000 (207)			4.50 (114.2)	2.25 (57.1)																				
BV□□-FNS12-10	3/4 Female NPT	6000 (414)	3000 (207)																								
BV□□-RT8-10	1/2 Male BSPT	6000 (414)	3000 (207)																								
BV□□-BP8-10	1/2 Male BSPP	6000 (414)	3000 (207)																								
BV□□-NS8-10	1/2 Male NPT	6000 (414)	3000 (207)																								
BV□□-RT12-10	3/4 Male BSPT	6000 (414)	3000 (207)			4.44 (112.8)	2.22 (56.4)																				
BV□□-BP12-10	3/4 Male BSPP	6000 (414)	3000 (207)																								
BV□□-NS12-10	3/4 Male NPT	6000 (414)	3000 (207)																								

3-way Valves

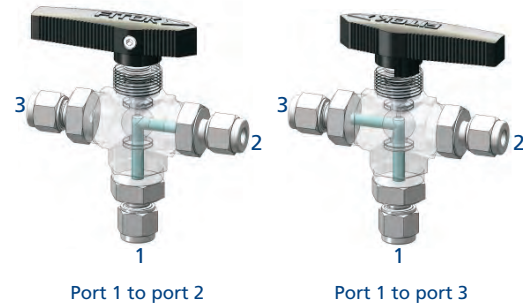
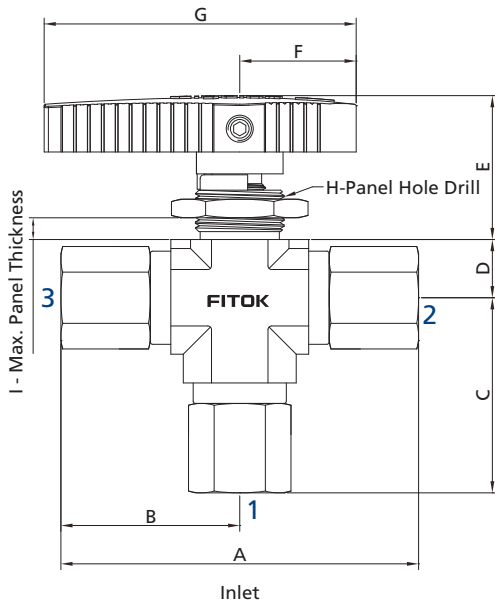

Ball Valves
Plug Valves

Basic Ordering Number	Connection Type and Size	Pressure Rating of End Connections @ 100°F (38°C), psig (bar)		Orifice in. (mm)	Cv	Dimensions, in. (mm)													
		316 SS	Brass			A	B	C	D	E	F	G	H	I					
BV□□-FL1-01-3	1/16" FITOK	6000 (414)	3000 (207)	0.05 (1.3)	0.06	2.60 (66.0)	1.30 (33.0)	1.35 (34.3)											
BV□□-FL2-02-3	1/8" FITOK	6000 (414)	3000 (207)	0.09 (2.4)	0.21	2.72 (69.0)	1.36 (34.5)	1.41 (35.8)											
BV□□-ML3-02-3	3 mm FITOK	6000 (414)	3000 (207)			2.74 (69.6)	1.37 (34.8)	1.42 (36.1)											
BV□□-FRT2-04-3	1/8 Female BSPT	6000 (414)	3000 (207)	0.12 (3.0)	0.28	2.14 (54.4)	1.07 (27.2)	1.12 (28.5)											
BV□□-FRP2-04-3	1/8 Female BSPP	6000 (414)	3000 (207)																
BV□□-FNS2-04-3	1/8 Female NPT	6000 (414)	3000 (207)								0.33 (8.5)	0.94 (23.9)	0.79 (20.0)	1.97 (50.0)	0.58 (14.7)	0.18 (4.6)			
BV□□-RT2-04-3	1/8 Male BSPT	6000 (414)	3000 (207)					2.36 (60.0)	1.18 (30.0)	1.23 (31.3)									
BV□□-BP2-04-3	1/8 Male BSPP	6000 (414)	3000 (207)																
BV□□-NS2-04-3	1/8 Male NPT	6000 (414)	3000 (207)																
BV□□-RT4-04-3	1/4 Male BSPT	6000 (414)	3000 (207)																
BV□□-BP4-04-3	1/4 Male BSPP	6000 (414)	3000 (207)					2.70 (68.6)	1.35 (34.3)	1.40 (35.6)									
BV□□-NS4-04-3	1/4 Male NPT	6000 (414)	3000 (207)																
BV□□-FL4-05-3	1/4" FITOK	6000 (414)	3000 (207)			0.19 (4.7)	0.70	3.48 (88.4)	1.74 (44.2)	1.88 (47.7)									
BV□□-ML6-05-3	6 mm FITOK	6000 (414)	3000 (207)					3.50 (89.0)	1.75 (44.5)	1.89 (48.0)									
BV□□-FL6-06-3	3/8" FITOK	6000 (414)	3000 (207)					3.60 (91.4)	1.80 (45.7)	1.94 (49.2)									
BV□□-ML8-06-3	8 mm FITOK	6000 (414)	3000 (207)					3.56 (90.4)	1.78 (45.2)	1.92 (48.7)									
BV□□-ML10-06-3	10 mm FITOK	6000 (414)	3000 (207)					3.62 (92.0)	1.81 (46.0)	1.95 (49.5)									
BV□□-FRT4-06-3	1/4 Female BSPT	6000 (414)	3000 (207)																
BV□□-FRP4-06-3	1/4 Female BSPP	6000 (414)	3000 (207)					3.02 (76.8)	1.51 (38.4)	1.65 (41.9)	0.48 (12.2)	1.24 (31.5)	0.59 (25.0)	2.64 (67.0)	0.77 (19.6)	0.25 (6.4)			
BV□□-FNS4-06-3	1/4 Female NPT	6000 (414)	3000 (207)																
BV□□-RT4-06-3	1/4 Male BSPT	6000 (414)	3000 (207)																
Bv□□-BP4-06-3	1/4 Male BSPP	6000 (414)	3000 (207)																
BV□□-NS4-06-3	1/4 Male NPT	6000 (414)	3000 (207)																
BV□□-RT6-06-3	3/8 Male BSPT	6000 (414)	3000 (207)			3.24 (82.2)	1.62 (41.1)	1.76 (44.6)											
BV□□-BP6-06-3	3/8 Male BSPP	6000 (414)	3000 (207)																
BV□□-NS6-06-3	3/8 Male NPT	6000 (414)	3000 (207)																

Basic Ordering Number	Connection Type and Size	Pressure Rating of End Connections @ 100°F (38°C), psig (bar)		Orifice in. (mm)	Cv	Dimensions, in. (mm)								
		316 SS	Brass			A	B	C	D	E	F	G	H	I
BV□□-FL8-10-3	1/2" FITOK	6000 (414)	2100 (145)	0.37 (9.5)	3.48	4.68 (118.8)	2.34 (59.4)	2.68 (68.1)	0.71 (18.0)	1.54 (39.0)	1.42 (36.0)	3.78 (96.0)	0.90 (22.9)	0.38 (9.7)
BV□□-FL12-10-3	3/4" FITOK	5800 (400)	1800 (124)			4.66 (118.4)	2.33 (59.2)	2.67 (67.9)						
BV□□-ML12-10-3	12 mm FITOK	6000 (414)	2000 (138)			4.84 (123.0)	2.42 (61.5)	2.76 (70.2)						
BV□□-ML14-10-3	14 mm FITOK	6000 (414)	1900 (131)											
BV□□-ML16-10-3	16 mm FITOK	5800 (400)	1700 (117)			3.90 (99.0)	1.95 (49.5)	2.29 (58.2)						
BV□□-ML18-10-3	18 mm FITOK	5400 (372)	1600 (110)											
BV□□-ML20-10-3	20 mm FITOK	5500 (379)	1600 (110)			4.30 (109.2)	2.15 (54.6)	2.49 (63.3)						
BV□□-ML22-10-3	22 mm FITOK	4900 (338)	1450 (100)											
BV□□-FRT6-10-3	3/8 Female BSPT	6000 (414)	3000 (207)			3.97 (101.0)	1.99 (50.5)	2.33 (59.1)						
BV□□-FRP6-10-3	3/8 Female BSPP	6000 (414)	3000 (207)											
BV□□-FNS6-10-3	3/8 Female NPT	6000 (414)	3000 (207)			4.30 (109.2)	2.15 (54.6)	2.49 (63.3)						
BV□□-FRT8-10-3	1/2 Female BSPT	6000 (414)	3000 (207)											
BV□□-FRP8-10-3	1/2 Female BSPP	6000 (414)	3000 (207)			4.50 (114.2)	2.25 (57.1)	2.59 (65.8)						
BV□□-FNS8-10-3	1/2 Female NPT	6000 (414)	3000 (207)											
BV□□-FRT12-10-3	3/4 Female BSPT	6000 (414)	3000 (207)			4.44 (112.8)	2.22 (56.4)	2.56 (65.1)						
BV□□-FRP12-10-3	3/4 Female BSPP	6000 (414)	3000 (207)											
BV□□-FNS12-10-3	3/4 Female NPT	6000 (414)	3000 (207)											
BV□□-RT8-10-3	1/2 Male BSPT	6000 (414)	3000 (207)											
BV□□-BP8-10-3	1/2 Male BSPP	6000 (414)	3000 (207)											
BV□□-NS8-10-3	1/2 Male NPT	6000 (414)	3000 (207)											
BV□□-RT12-10-3	3/4 Male BSPT	6000 (414)	3000 (207)											
BV□□-BP12-10-3	3/4 Male BSPP	6000 (414)	3000 (207)											
BV□□-NS12-10-3	3/4 Male NPT	6000 (414)	3000 (207)											

Angle Pattern Valves

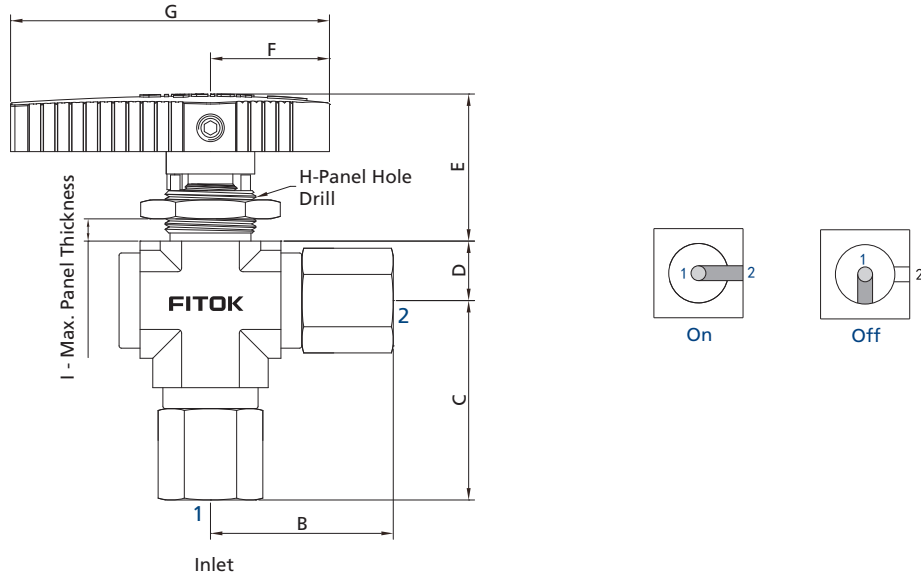

Ball Valves
Plug Valves

Basic Ordering Number	Connection Type and Size	Pressure Rating of End Connections @ 100°F (38°C), psig (bar)		Orifice in. (mm)	Cv	Dimensions, in. (mm)														
		316 SS	Brass			B	C	D	E	F	G	H	I							
BV□□-FL1-01-A	1/16" FITOK	6000 (414)	3000 (207)	0.05 (1.3)	0.06	1.30 (33.0)	1.35 (34.3)													
BV□□-FL2-02-A	1/8" FITOK	6000 (414)	3000 (207)	0.09 (2.4)	0.21	1.36 (34.5)	1.41 (35.8)													
BV□□-ML3-02-A	3 mm FITOK	6000 (414)	3000 (207)			1.37 (34.8)	1.42 (36.1)													
BV□□-FRT2-04-A	1/8 Female BSPT	6000 (414)	3000 (207)	0.12 (3.0)	0.28	1.07 (27.2)	1.12 (28.5)													
BV□□-FRP2-04-A	1/8 Female BSPP	6000 (414)	3000 (207)																	
BV□□-FNS2-04-A	1/8 Female NPT	6000 (414)	3000 (207)							0.33 (8.5)	0.94 (23.9)	0.79 (20.0)	1.97 (50.0)	0.58 (14.7)	0.18 (4.6)					
BV□□-RT2-04-A	1/8 Male BSPT	6000 (414)	3000 (207)					1.18 (30.0)	1.23 (31.3)											
BV□□-BP2-04-A	1/8 Male BSPP	6000 (414)	3000 (207)																	
BV□□-NS2-04-A	1/8 Male NPT	6000 (414)	3000 (207)																	
BV□□-RT4-04-A	1/4 Male BSPT	6000 (414)	3000 (207)																	
BV□□-BP4-04-A	1/4 Male BSPP	6000 (414)	3000 (207)					1.35 (34.3)	1.40 (35.6)											
BV□□-NS4-04-A	1/4 Male NPT	6000 (414)	3000 (207)																	
BV□□-FL4-05-A	1/4" FITOK	6000 (414)	3000 (207)			0.19 (4.7)	0.70	1.74 (44.2)	1.88 (47.7)											
BV□□-ML6-05-A	6 mm FITOK	6000 (414)	3000 (207)							1.75 (44.5)	1.89 (48.0)									
BV□□-FL6-06-A	3/8" FITOK	6000 (414)	2200 (152)							1.80 (45.7)	1.94 (49.2)									
BV□□-ML8-06-A	8 mm FITOK	6000 (414)	2300 (159)					1.78 (45.2)	1.92 (48.7)											
BV□□-ML10-06-A	10 mm FITOK	6000 (414)	1900 (131)					1.81 (46.0)	1.95 (49.5)											
BV□□-FRT4-06-A	1/4 Female BSPT	6000 (414)	3000 (207)																	
BV□□-FRP4-06-A	1/4 Female BSPP	6000 (414)	3000 (207)																	
BV□□-FNS4-06-A	1/4 Female NPT	6000 (414)	3000 (207)							0.48 (12.2)	1.24 (31.5)	0.59 (25.0)	2.64 (67.0)	0.77 (19.6)	0.25 (6.4)					
BV□□-RT4-06-A	1/4 Male BSPT	6000 (414)	3000 (207)																	
Bv□□-BP4-06-A	1/4 Male BSPP	6000 (414)	3000 (207)																	
BV□□-NS4-06-A	1/4 Male NPT	6000 (414)	3000 (207)																	
BV□□-RT6-06-A	3/8 Male BSPT	6000 (414)	3000 (207)																	
BV□□-BP6-06-A	3/8 Male BSPP	6000 (414)	3000 (207)																	
BV□□-NS6-06-A	3/8 Male NPT	6000 (414)	3000 (207)					1.62 (41.1)	1.76 (44.6)											

Basic Ordering Number	Connection Type and Size	Pressure Rating of End Connections @ 100°F (38°C), psig (bar)		Orifice in. (mm)	Cv	Dimensions, in. (mm)							
		316 SS	Brass			B	C	D	E	F	G	H	I
BV□□-FL8-10-A	1/2" FITOK	6000 (414)	2100 (145)	0.37 (9.5)	3.48	2.34(59.4)	2.68(68.1)	0.71 (18.0)	1.54 (39.0)	1.42 (36.0)	3.78 (96.0)	0.90 (22.9)	0.38 (9.7)
BV□□-FL12-10-A	3/4" FITOK	5800 (400)	1800 (124)			2.33 (59.2)	2.67 (67.9)						
BV□□-ML12-10-A	12 mm FITOK	6000 (414)	2000 (138)			2.42 (61.5)	2.76 (70.2)						
BV□□-ML14-10-A	14 mm FITOK	6000 (414)	1900 (131)										
BV□□-ML16-10-A	16 mm FITOK	5800 (400)	1700 (117)			1.95 (49.5)	2.29 (58.2)						
BV□□-ML18-10-A	18 mm FITOK	5400 (372)	1600 (110)										
BV□□-ML20-10-A	20 mm FITOK	5500 (379)	1600 (110)			2.15 (54.6)	2.49 (63.3)						
BV□□-ML22-10-A	22 mm FITOK	4900 (338)	1450 (100)										
BV□□-FRT6-10-A	3/8 Female BSPT	6000 (414)	3000 (207)			1.99 (50.5)	2.33 (59.1)						
BV□□-FRP6-10-A	3/8 Female BSPP	6000 (414)	3000 (207)										
BV□□-FNS6-10-A	3/8 Female NPT	6000 (414)	3000 (207)			2.15 (54.6)	2.49 (63.3)						
BV□□-FRT8-10-A	1/2 Female BSPT	6000 (414)	3000 (207)										
BV□□-FRP8-10-A	1/2 Female BSPP	6000 (414)	3000 (207)			2.25 (57.1)	2.59 (65.8)						
BV□□-FNS8-10-A	1/2 Female NPT	6000 (414)	3000 (207)										
BV□□-FRT12-10-A	3/4 Female BSPT	6000 (414)	3000 (207)			2.22 (56.4)	2.56 (65.1)						
BV□□-FRP12-10-A	3/4 Female BSPP	6000 (414)	3000 (207)										
BV□□-FNS12-10-A	3/4 Female NPT	6000 (414)	3000 (207)										
BV□□-RT8-10-A	1/2 Male BSPT	6000 (414)	3000 (207)										
BV□□-BP8-10-A	1/2 Male BSPP	6000 (414)	3000 (207)										
BV□□-NS8-10-A	1/2 Male NPT	6000 (414)	3000 (207)										
BV□□-RT12-10-A	3/4 Male BSPT	6000 (414)	3000 (207)										
BV□□-BP12-10-A	3/4 Male BSPP	6000 (414)	3000 (207)										
BV□□-NS12-10-A	3/4 Male NPT	6000 (414)	3000 (207)										

1. FITOK means FITOK double ferrule tube fittings.
2. Sizes and types listed are standard. Other sizes and types are available upon request, please contact FITOK Group or our authorized distributors.
3. Dimensions are shown with tube fitting nuts finger-tightened. All dimensions are for reference only and are subject to change.
For dimensions not shown above, please contact FITOK Group or our authorized distributors.

Ordering Number Description

BVSS - FL8 - ML12 - ML10 - P06 - RXHQ3 - SCEF2

Ball Valves
Plug Valves

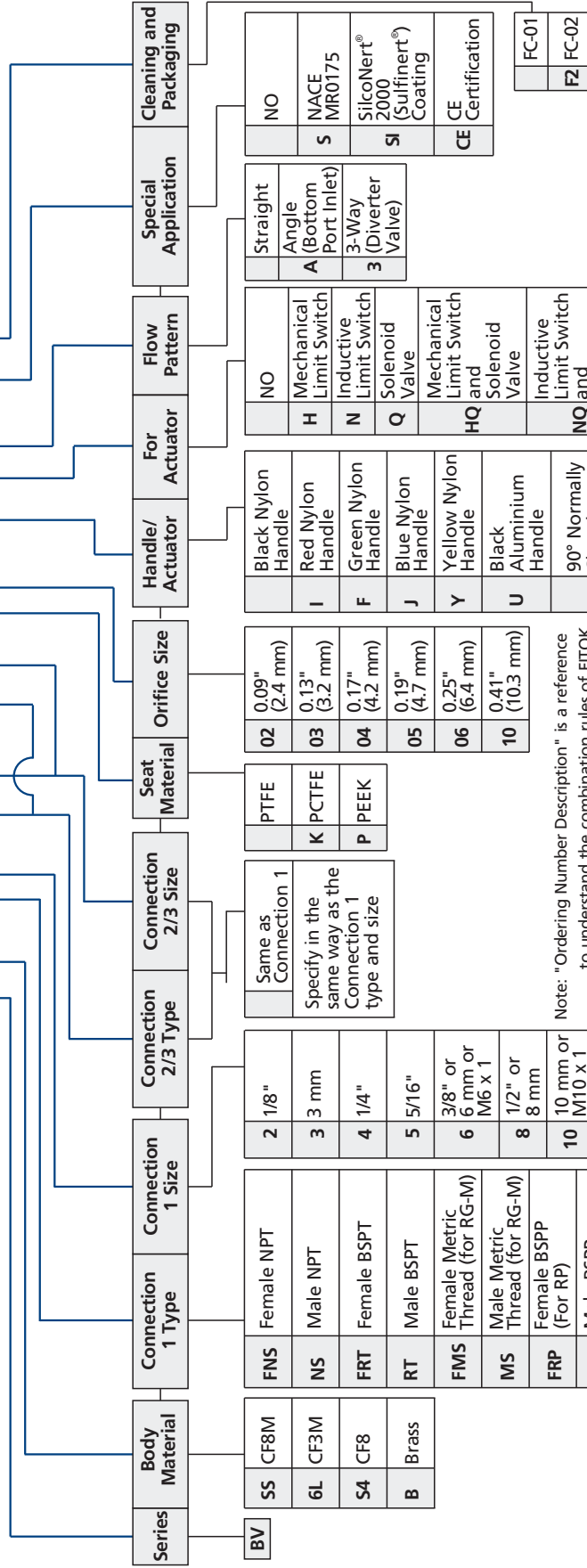

Series	Body Material	Connection 1 Type	Connection 1 Size	Connection 2/3 Type	Connection 2/3 Size	Seat Material	Orifice Size	Handle/Actuator	For Actuator	Flow Pattern	Special Application	Cleaning and Packaging
BV	SS CF8M	FNS Female NPT	2 1/8"	Same as Connection 1	02 0.09" (2.4 mm)	PTFE	I Black Nylon Handle	H Mechanical Limit Switch	NO	Straight	NO	
	6L CF3M	NS Male NPT	3 3 mm	Specify in the same way as the Connection 1 type and size	03 0.13" (3.2 mm)	K PCTFE	F Red Nylon Handle	N Inductive Limit Switch	S NACE MR0175	Angle (Bottom Port Inlet)	S	
	S4 CF8	FRT Female BSPT	4 1/4"		04 0.17" (4.2 mm)	P PEEK	J Green Nylon Handle	Q Solenoid Valve	SI SilcoNert® 2000 (Sulfinert®) Coating	3-Way (Diverter Valve)	SI	
	B Brass	RT Male BSPT	5 5/16"		05 0.19" (4.7 mm)		Y Yellow Nylon Handle	HQ and Solenoid Valve	CE Certification		CE	
		FMS Female Metric Thread (for RG-M)	6 3/8" or 6 mm or M6 x 1		06 0.25" (6.4 mm)		U Black Aluminium Handle	Inductive Limit Switch Solenoid Valve				
		MS Male Metric Thread (for RG-M)	8 1/2" or 8 mm		10 0.41" (10.3 mm)		C 90° Normally Closed Pneumatic Actuator	Inductive Limit Switch Solenoid Valve				FC-01
		FRP Female BSPP (For RP)	10 10 mm or M10 x 1				O 90° Normally Open Pneumatic Actuator					F2 FC-02
		BP Male BSPP (For RG)	12 3/4" or 12 mm				D 90° Double Acting Pneumatic Actuator					
		FL Fractional Tube Fitting	14 14 mm or M14 x 1.5				LX 180° Left End Normally Open Pneumatic Actuator					
		ML Metric Tube Fitting	16 16 mm				RX 180° Right End Normally Open Pneumatic Actuator					
		UFB Rotatable Fractional Tube Butt Weld	18 18 mm				DX 180° Double Acting Pneumatic Actuator					
		UMB Rotatable Metric Tube Butt Weld	20 20 mm or M20 x 1.5				E 90° Electric Actuator					
		UPB Nut + Gasket + Pipe Bulged Nipple	22 22 mm or M22 x 1.5				EX 180° Electric Actuator					
			24 M24 x 1.5									

Note: "Ordering Number Description" is a reference to understand the combination rules of FITOK product part number. Not all combinations are available.

- Standard thread pitch for metric threads are as follows:
M10 and below: 1 mm
M12 to M24: 1.5 mm
Standard thread pitch should be omitted in the ordering number, others should be specified.
- For oxygen-enriched environment or hazardous media service, contact FITOK Group or our authorized distributors.
- Cleaning and Packaging:
FC-01: Standard cleaning and packaging for general industrial procedures.
FC-02: Special cleaning and packaging for wetted system components to ensure compliance with product cleaning requirement of ASTM G93 Level C.
- For more information about pneumatic actuator ball valves, please refer to the catalog **Automatic Control Ball Valves**.
- SilcoNert® 2000 (Sulfinert®) Coating: Except for ball valves with PEEK seat, wetted metal components SilcoNert® 2000 (Sulfinert®) coated.
- CE certification is available. For more information, please contact FITOK group or our authorized distributors

High Temperature Metal-seated Ball Valves

BK Series

Features

- ⦿ 3-piece precision cast body construction
- ⦿ Free floating ball design provides seat wear compensation
- ⦿ Ball and seats mate-lapped for 100% contact ensures absolute shutoff
- ⦿ High temperature resistant sealing materials for thermal service up to 662°F (350°C)
- ⦿ Blowout-proof stem
- ⦿ Positive handle stop
- ⦿ Orifice sizes: 0.5" (12.7 mm), 1" (25.4 mm), 1.5" (38.1 mm)
- ⦿ Variety of end connections
- ⦿ Test Standard: Low pressure gas tightness FCI 70-2 Class VI
High pressure liquid test ISO 5208 Rate D



Technical Data

Orifice, in. (mm)	0.5 (12.7), 1 (25.4), 1.5 (38.1)	
Material	316/304 SS	
Connection Type	FITOK Tube Fitting	Weld Fitting
Temperature, °F (°C)	-65 (-54) to 662 (350)	
Working Pressure, psig (bar)	1000 (69)	

Standard Materials of Construction

Ball Valves
Plug Valves

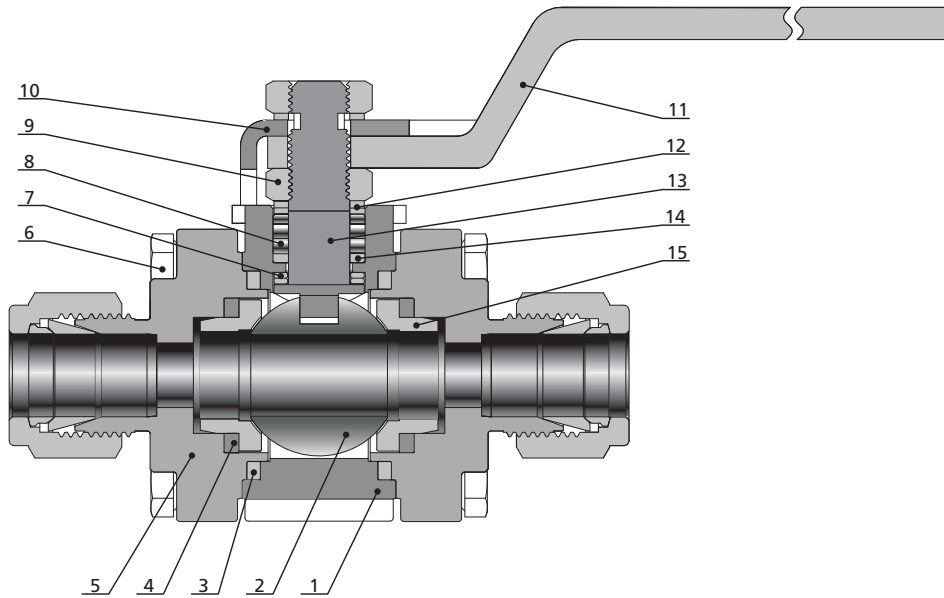

Item	Component	Material	
1	<i>Body</i>	<i>CF8M/A351</i>	<i>CF8/A351</i>
2	<i>Ball</i>	<i>316/304 SS, HVOF-sprayed WC coatings</i>	
3	<i>Flange Seal</i>	<i>Graphite</i>	
4	<i>Seat Packing</i>	<i>Graphite</i>	
5	<i>End Connection</i>	<i>CF8M/A351</i>	<i>CF8/A351</i>
6	Hex Bolt	Stainless Steel	
7	<i>Stem Bearing</i>	<i>Stellite 6/AMS5387</i>	
8	<i>Packing</i>	<i>Graphite</i>	
9	Hex Nut	316 SS/A479	
10	Stop Plate	304 SS/A240	
11	Handle	304 SS/A240	
12	Stem Spring	Strain-hardened 316 SS/A240	
13	<i>Stem</i>	<i>316 SS/A479</i>	
14	<i>Stem Washer</i>	<i>316 SS/A479</i>	
15	<i>Seat</i>	<i>316 SS/A479, hardfacing stellite</i>	<i>304 SS/A479, hardfacing stellite</i>

Note: Wetted components are listed in italics. For other materials, please contact FITOK Group or our authorized distributors.

Dimensions

Dimensions are for reference only and are subject to change.

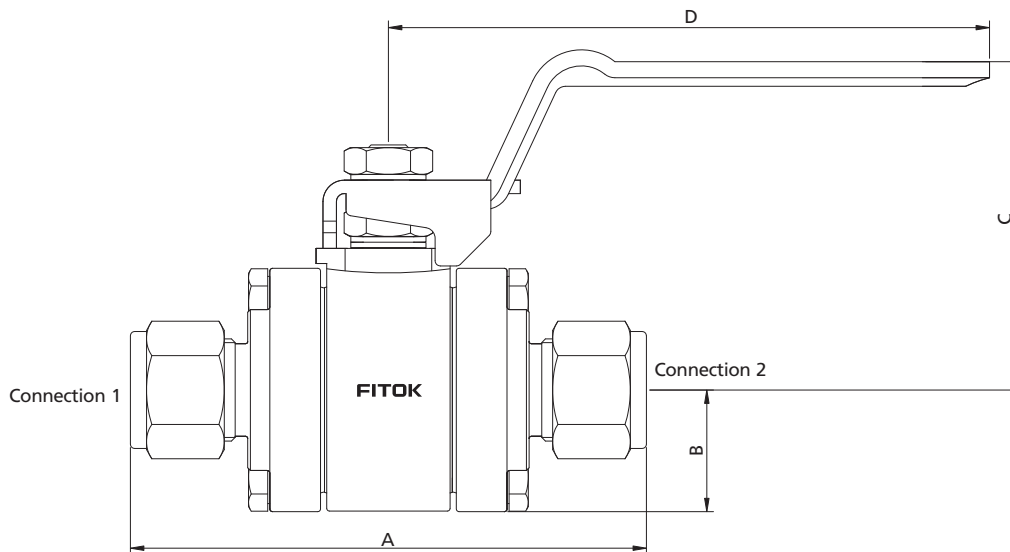

Basic Ordering Information	Connection Type		Orifice in. (mm)	Dimensions, in. (mm)				
	Connection 1	Connection 2		A	B	C	D	
BK□□-FL8-13G	1/2" FITOK	1/2" FITOK	0.41 (10.4)	3.79" (96.2)	0.89" (22.7)	2.25" (57.1)	6.5" (165)	
BK□□-FL10-13G	5/8" FITOK	5/8" FITOK	0.5 (12.7)	3.79" (96.2)	0.89" (22.7)	2.25" (57.1)	6.5" (165)	
BK□□-FL12-13G	3/4" FITOK	3/4" FITOK		3.92" (99.6)	0.89" (22.7)	2.25" (57.1)	6.5" (165)	
BK□□-ML16-13G	16 mm FITOK	16 mm FITOK		3.92" (99.6)	0.89" (22.7)	2.25" (57.1)	6.5" (165)	
BK□□-ML18-13G	18 mm FITOK	18 mm FITOK		3.91" (99.4)	0.89" (22.7)	2.25" (57.1)	6.5" (165)	
BK□□-TB12-13G	3/4" Tube Butt Weld	3/4" Tube Butt Weld		3.8" (96.6)	0.89" (22.7)	2.25" (57.1)	6.5" (165)	
BK□□-TS12-13G	3/4" Tube Socket Weld	3/4" Tube Socket Weld		3.2" (80.2)	0.89" (22.7)	2.25" (57.1)	6.5" (165)	
BK□□-PB8-13G	1/2" Pipe Butt Weld	1/2" Pipe Butt Weld		3.24" (82.34)	0.89" (22.7)	2.25" (57.1)	6.5" (165)	
BK□□-PB12-13G	3/4" Pipe Butt Weld	3/4" Pipe Butt Weld		3.24" (82.34)	0.89" (22.7)	2.25" (57.1)	6.5" (165)	
BK□□-TB24-25G	1 1/2" Tube Butt Weld	1 1/2" Tube Butt Weld		1 (25.4)	—	—	—	—
BK□□-TS20-25G	1 1/4" Tube Socket Weld	1 1/4" Tube Socket Weld			—	—	—	—
BK□□-PB20-25G	1 1/4" Pipe Butt Weld	1 1/4" Pipe Butt Weld	—		—	—	—	
BK□□-TB32-38G	2" Tube Butt Weld	2" Tube Butt Weld	1.5 (38.1)	—	—	—	—	
BK□□-PB24-38G	1 1/2" Pipe Butt Weld	1 1/2" Pipe Butt Weld		—	—	—	—	
BK□□-PS24-38G	1 1/2" Pipe Socket Weld	1 1/2" Pipe Socket Weld		—	—	—	—	

1. Connection type of "FITOK" means FITOK double ferrule tube fittings.
2. Sizes and types listed are standard. Other sizes and types are available upon request. For details, please contact FITOK Group or our authorized distributors.
3. Dimensions are shown with FITOK tube fitting nuts finger-tight. For dimensions not shown above, please contact FITOK Group or our authorized distributors.

Ordering Number Description

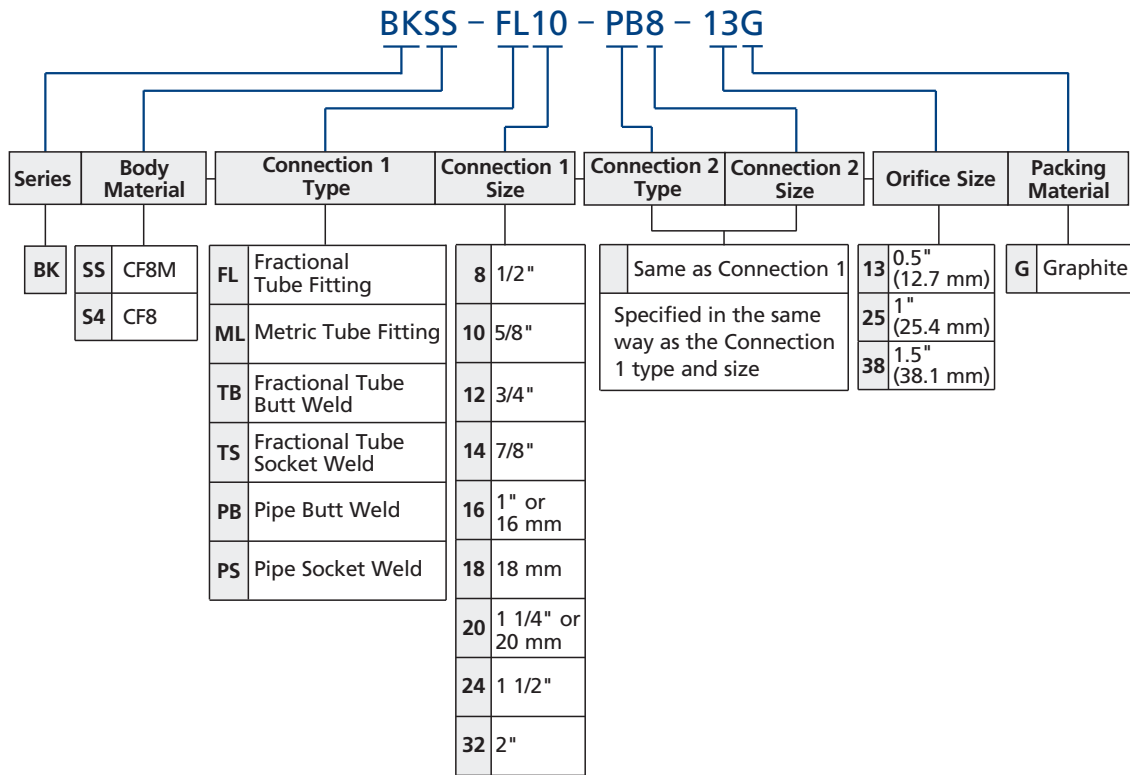

NOTE: "Ordering Number Description" is a reference to understand the combination rules of FITOK product part number. Not all combinations are available.

Alternative Fuel Service (AFS) Ball Valves

BU Series

Features

- ⦿ Working pressures up to 6000 psig (413 bar)
- ⦿ Working temperature: -40 to 250°F (-40 to 121°C)
- ⦿ High flow-Cv from 4.0 to 13.8
- ⦿ Low-temperature fluorocarbon material provides sealing capability over full temperature range
- ⦿ Spring-loaded seat provides leak-tight integrity in both low-and high-pressure systems and reduces seat wear from pressure surges
- ⦿ A variety of end connections available
- ⦿ Low operating torque
- ⦿ All wetted components are compatible with hydrogen and compressed natural gas (CNG)
- ⦿ No packing adjustment required
- ⦿ Bi-directional flow
- ⦿ Options for handle colors
- ⦿ Pneumatic actuators available
- ⦿ Each valve is leak tested with Nitrogen or compressed air at working pressure to meet a requirement of no visible leak
- ⦿ Field repairable with seal kit
- ⦿ ECE R110 type approval available

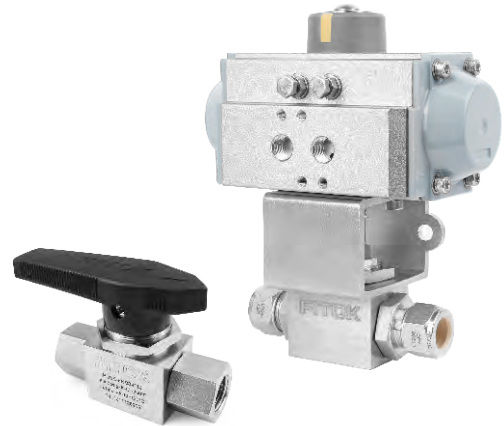

Pressure VS Temperature Ratings

End Connection	FITOK Tube Fitting			Female Pipe	
	3/8, 1/2 in., 12 mm	3/4 in., 16 mm	1 in.	3/8, 1/2 in.	3/4 in.
Temperature °F (°C)	Working Pressure, psig (bar)				
-40 (-40) ~ 250 (121)	6000 (414)	5800 (400)	4700 (324)	6000 (414)	6000 (414)

Note: Ratings are based on valves of standard materials.

Standard Materials of Construction

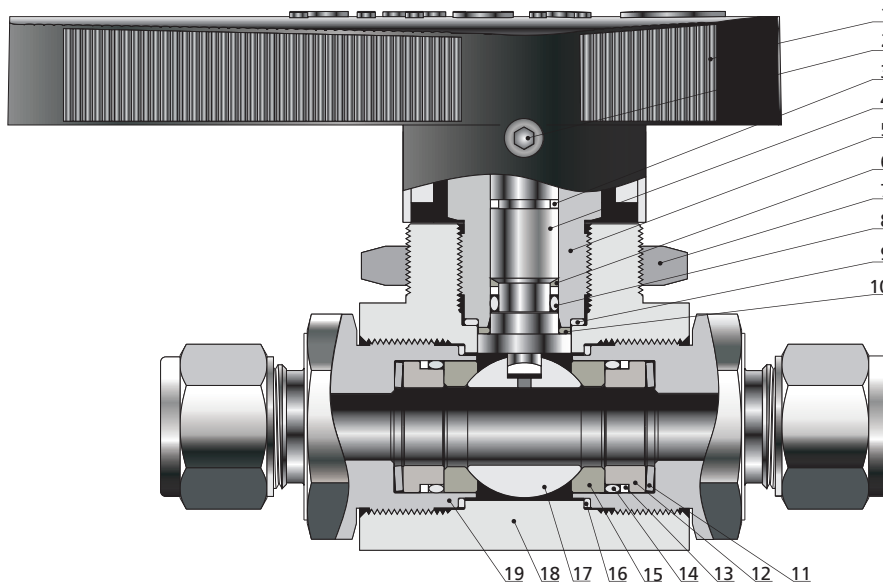

Item	Component	Material/ASTM Specification
1	Handle	Nylon with stainless steel insert
2	Set screw	Zinc-plated carbon steel
3	<i>Guide ring</i>	<i>PTFE/D1710</i>
4	<i>Stem</i>	<i>316 SS/A479</i>
5	<i>Packing bolt</i>	<i>316 SS/A479</i>
6	<i>Stem backup ring</i>	<i>PEEK</i>
7	Lock nut	316 SS/A479
8	<i>Stem O-ring</i>	<i>Low-temperature fluorocarbon</i>
9	<i>Packing bolt washer</i>	<i>Silver-plated 316 SS/A269</i>
10	<i>Thrust washer</i>	<i>PEEK</i>
11	<i>Coned-disc spring</i>	<i>316 SS/A240</i>
12	<i>Seat gland</i>	<i>316 SS/A479</i>
13	<i>Seat backup ring</i>	<i>PTFE/D1710</i>
14	<i>Seat O-ring</i>	<i>Low-temperature fluorocarbon</i>
15	<i>Seat</i>	<i>PEEK</i>
16	<i>End connection gasket</i>	<i>Silver-plated 316 SS/A269</i>
17	<i>Ball</i>	<i>316 SS/A479</i>
18	<i>Body</i>	<i>316 SS/A479</i>
19	<i>End connection</i>	<i>316 SS/A479</i>
	<i>Lubricant</i>	<i>PTFE-based</i>

Note: Wetted components listed in italics.

Dimensions

Dimensions in in. (mm) are for reference only and subject to change.

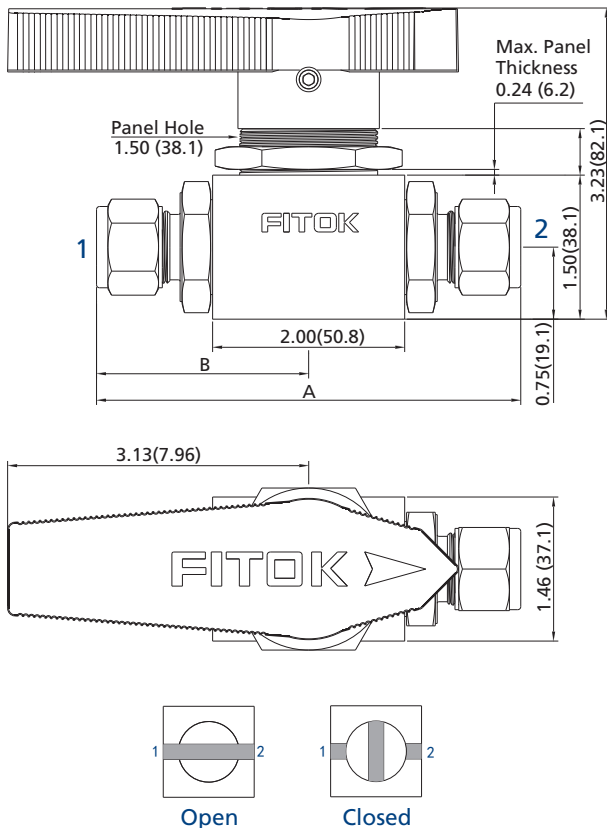

Ordering Number	Connection ^① Type and Size	Cv	Orifice in. (mm)	Dimensions in. (mm)	
				A	B
BUSS-ML10-P12	10 mm FITOK	5.2	0.31 (7.9)	4.21 (107)	2.11 (53.5)
BUSS-ML12-P12	12 mm FITOK	5.2	0.41 (10.3)	4.42 (112.2)	2.21 (56.1)
BUSS-ML16-P12	16 mm FITOK	12.4	0.47 (12.0)	4.42 (112.3)	2.21 (56.2)
BUSS-FL6-P12	3/8" FITOK	4.0	0.28 (7.1)	4.20 (106.6)	2.10 (53.3)
BUSS-FL8-P12	1/2" FITOK	7.2	0.41 (10.3)	4.40 (111.8)	2.20 (55.9)
BUSS-FL12-P12	3/4" FITOK	7.1	0.47 (12.0)	4.50 (114.3)	2.46 (62.5)
BUSS-FL16-P12 ^②	1" FITOK	6.5	0.47 (12.0)	4.93 (125.1)	2.25 (57.1)
BUSS-FNS6-P12	3/8" Female NPT	11.0	0.47 (12.0)	4.01 (102)	2.00 (50.8)
BUSS-FNS8-P12	1/2" Female NPT	13.8		4.01 (102)	2.00 (50.8)
BUSS-FNS12-P12	3/4" Female NPT	7.8		4.13 (105)	2.06 (52.3)
BUSS-FRT8-P12	1/2" Female BSPT	13.8		4.01 (102)	2.00 (50.8)

Note: Dimensions shown with FITOK tube fitting nuts finger-tight.

① Valves can be ordered with two different end connections. Contact FITOK Group or our authorized distributors.

② Not recommended for panel mounting; not available with pneumatic actuator.

CNG/NGV Application

ECE R110 Manual Service Valve Type Approval

Classification: Class 0

Temperature: -40 to 248°F (-40 to 120°C)

Pressure: 3370 psig (260 bar)

To order, add **-R110** to the valve ordering number.

Example: BUSS-ML12-P12-**R110**

Seal kit for field replacement is available, see "Seal Kits".

Seal Kits

Seal Kit Name	Seal Kit Ordering Number	Seal Kit Content
Seat seal kit	SS-BU-P-SE	Seat, seat backup ring, seat O-ring, coned-disc spring, end connection gasket, instructions.
Stem and seat seal kit	SS-BU-P	Guide ring, stem backup ring, stem O-ring, packing bolt washer, thrust washer, seat, seat backup ring, seat O-ring, coned-disc spring, end connection gasket, instructions

Ordering Number Description

BUSS – ML12 – FL12 – P12 – OHQL – SF2

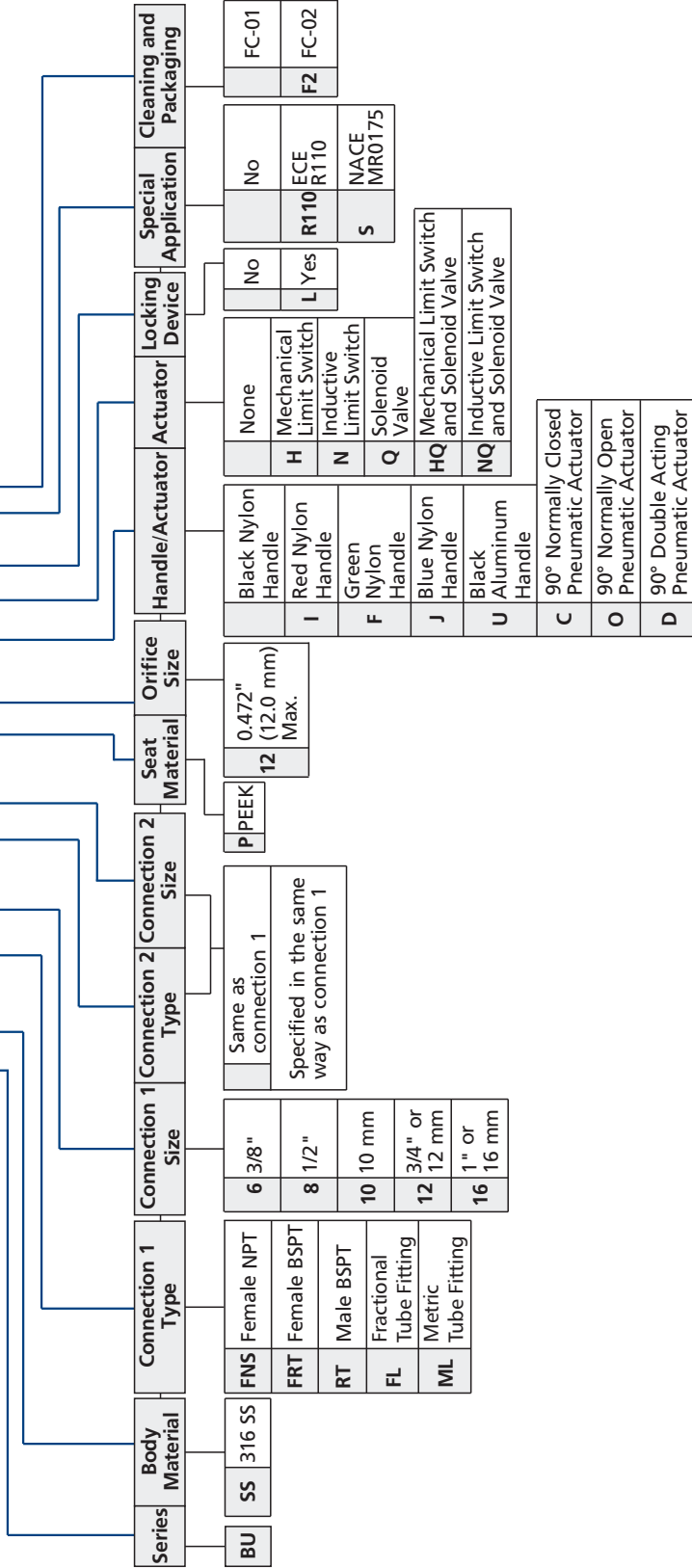

Note: "Ordering Number Description" is a reference to understand the combination rules of FITOK product part number. Not all combinations are available.

- Standard thread pitch for metric threads are as follows:
M10 and below: 1 mm
M12 to M24: 1.5 mm

Standard thread pitch is omitted in ordering number.

For special thread pitch, specify in the ordering number.

- For oxygen-enriched environment or hazardous media service, contact FITOK Group or our authorized distributors.

3. Cleaning and Packaging:

FC-01: Standard cleaning and packaging for general industrial procedures.

FC-02: Special cleaning and packaging for wetted system components to ensure compliance with product cleaning requirement of ASTM G93 Level C.

- For more details about ball valves with pneumatic actuators, refer to Automatic Control Ball Valves.

- Certifications do not include attachments to the valve, such as actuators or a different handle mechanism.

info@fitokgroup.com
www.fitokgroup.com

FK-IC-GV-01-EN-220211